

64-Channel Serial-to-Parallel Converter with High-Voltage Push-Pull Outputs

Features

- Up to 300V Output Voltage
- Low-power Level Shifting from 5V to 300V
- Shift Register Speed:
 - 8 MHz at $V_{DD} = 5V$
- Latched Data Outputs
- Output Polarity and Blanking
- CMOS-compatible Inputs
- Forward and Reverse Shifting Options

Applications

- Display Driver
- Print Head Driver
- Microelectromechanical Systems Applications

General Description

The HV507 is a low-voltage to high-voltage serial-to-parallel converter with 64 push-pull outputs. This device is designed as a printer driver for electrostatic applications. It can also be used in any application requiring multiple-output high-voltage low-current sourcing-and-sinking capabilities.

The device consists of a 64-bit Shift register, 64 latches and control logic to perform the polarity select and blanking of the outputs. A DIR pin controls the direction of data shift through the device. With the DIR grounded, D_{IOA} is data in and D_{IOB} is data out. Data is shifted from HV_{OUT64} to HV_{OUT1} . When DIR is at logic high, D_{IOB} is data in and D_{IOA} is data out. The data is then shifted from HV_{OUT1} to HV_{OUT64} through the Shift register on the low-to-high transition of the clock. Data output buffers are provided for cascading devices. The operation of the shift register is not affected by the latch enable (\overline{LE}), blanking (\overline{BL}) and polarity (POL) inputs. Transfer of data from the Shift register to the latch occurs when the \overline{LE} is high. The data in the latch is stored during \overline{LE} transition from high to low.

Package Type

80-lead PQFP
(Top view)

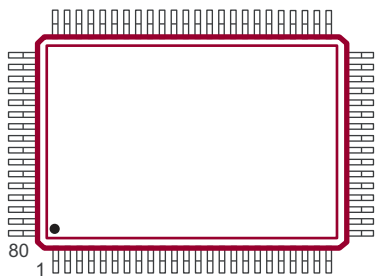

See [Table 2-1](#) for pin information.

HV507

Functional Block Diagram

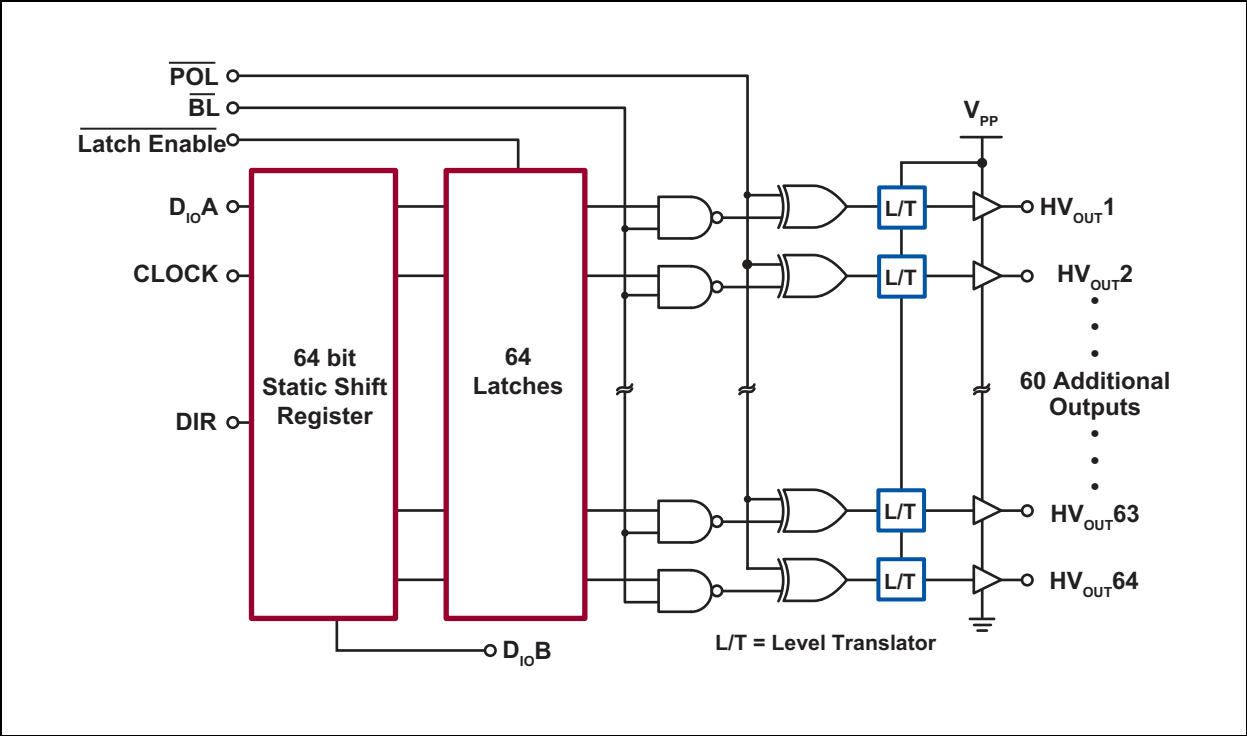

Typical Application Circuit

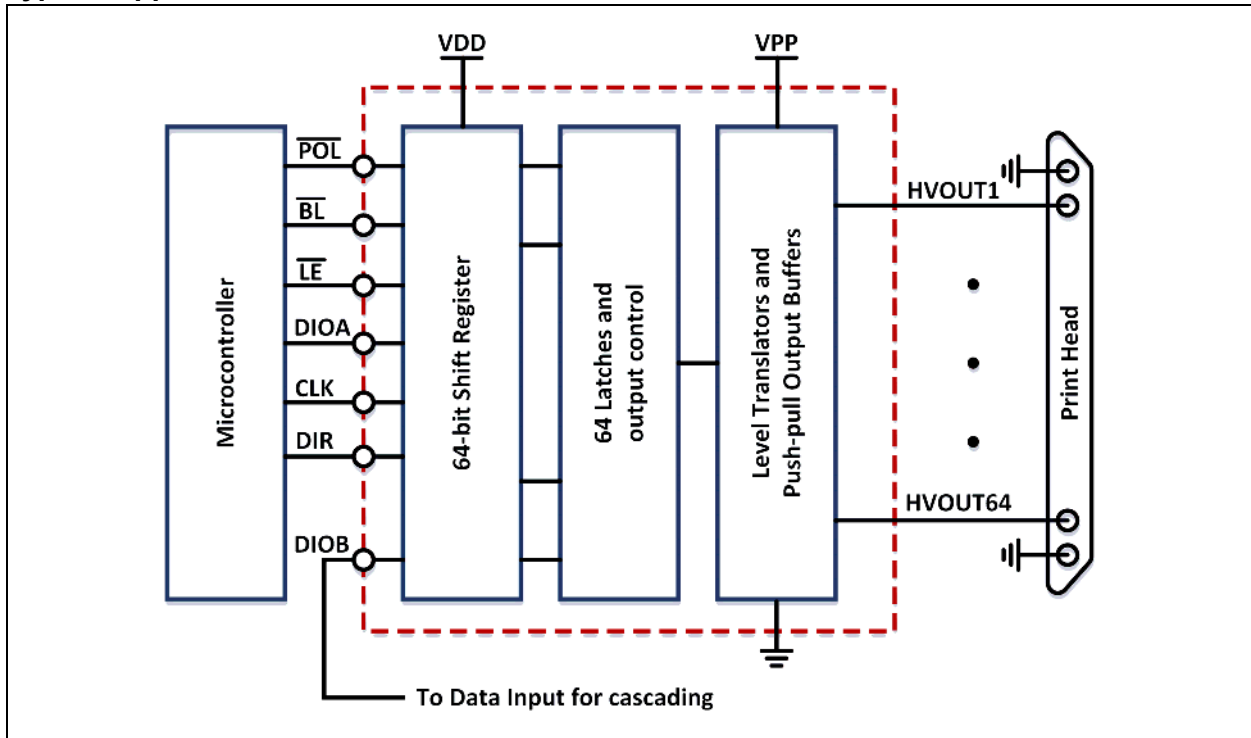

HV507

1.0 ELECTRICAL CHARACTERISTICS

Absolute Maximum Ratings†

Low-supply Voltage, V_{DD}	-0.5V to +6V
High-supply Voltage, V_{PP}	V_{DD} to +320V
Logic Input Levels	-0.5V to $V_{DD}+0.5V$
Ground Current (Note 2)	0.5A
High-voltage Supply Current (Note 1)	0.5A
Operating Ambient Temperature, T_A	0°C to +70°C
Storage Temperature, T_S	-65°C to +150°C
Continuous Total Power Dissipation:	
80-lead PQFP (Note 2)	1200 mW

† **Notice:** Stresses above those listed under “Absolute Maximum Ratings” may cause permanent damage to the device. This is a stress rating only, and functional operation of the device at those or any other conditions above those indicated in the operational sections of this specification is not intended. Exposure to maximum rating conditions for extended periods may affect device reliability.

Note 1: Connection to all power and ground pads is required. Duty cycle is limited by the total power dissipated in the package.

2: For operations above 25°C ambient, derate linearly to 70°C at 26.7 mW/°C.

RECOMMENDED OPERATING CONDITIONS

Parameter	Sym.	Min.	Typ.	Max.	Unit	Conditions
Logic Supply Voltage	V_{DD}	4.5	5	5.5	V	
High-voltage Supply Voltage	V_{PP}	60	—	300	V	
High-level Input Voltage	V_{IH}	$V_{DD}-0.9V$	—	V_{DD}	V	
Low-level Input Voltage	V_{IL}	0	—	0.9	V	

DC ELECTRICAL CHARACTERISTICS

Electrical Specifications: For $V_{DD} = 5V$, $V_{PP} = 300V$ and $T_A = 25^\circ C$.						
Parameter	Sym.	Min.	Typ.	Max.	Unit	Conditions
V_{DD} Supply Current	I_{DD}	—	—	15	mA	$f_{CLK} = 8\text{ MHz}$, $f_{DATA} = 4\text{ MHz}$, $\overline{LE} = \text{low}$
Quiescent V_{DD} Supply Current	I_{DDQ}	—	—	200	μA	All $V_{IN} = 0V$ or V_{DD}
High-voltage Supply Current	I_{PP}	—	—	0.5	mA	$V_{PP} = 300V$, all outputs high
		—	—	0.5	mA	$V_{PP} = 300V$, all outputs low
High-level Logic Input Current	I_{IH}	—	—	10	μA	$V_{IN} = V_{DD}$
Low-level Logic Input Current	I_{IL}	—	—	-10	μA	$V_{IN} = 0V$
High-level Output	HV _{OUT}	265	—	—	V	$V_{PP} = 300V$, $I_{HV_{OUT}} = -1\text{ mA}$, $I_{D_{OUT}} = -100\ \mu A$
	Data Out	$V_{DD} - 1$	—	—	V	
Low-level Output	HV _{OUT}	—	—	35	V	$V_{DD} = 5V$, $I_{HV_{OUT}} = 1\text{ mA}$, $I_{D_{OUT}} = 100\ \mu A$
	Data Out	—	—	1	V	
HV _{OUT} Clamp Voltage	V_{OC}	—	—	$V_{PP} + 1.5$	V	$I_{OL} = 1\text{ mA}$
		—	—	-30	V	$I_{OL} = -1\text{ mA}$

AC ELECTRICAL CHARACTERISTICS

Electrical Specifications: For $V_{DD} = 5V$, $V_{PP} = 300V$ and $T_A = 25^\circ C$. Shift register speed can be as low as DC as long as data set-up and hold time meet the specifications.						
Parameter	Sym.	Min.	Typ.	Max.	Unit	Conditions
Clock Frequency	f_{CLK}	—	—	8	MHz	
Clock Width High or Low	t_{WL} , t_{WH}	62	—	—	ns	
Data Set-up Time before Clock Rises	t_{SU}	35	—	—	ns	
Data Hold Time after Clock Rises	t_H	30	—	—	ns	
Time from Latch Enable to HV _{OUT}	t_{ON} , t_{OFF}	—	—	4	ns	$C_L = 20\text{ pF}$
Latch Enable Pulse Width	t_{WLE}	80	—	—	ns	
Delay Time Clock to Latch Enable Low to High	t_{DLE}	35	—	—	ns	
Latch Enable Set-up Time before Clock Rises	t_{SLE}	40	—	—	ns	
Delay Time Clock to Data Low to High	t_{DLH}	—	—	125	ns	$C_L = 20\text{ pF}$
Delay Time Clock to Data High to Low	t_{DHL}	—	—	125	ns	$C_L = 20\text{ pF}$
All Logic Inputs	t_r , t_f	—	—	5	ns	

HV507

TEMPERATURE SPECIFICATIONS

Parameter	Sym.	Min.	Typ.	Max.	Unit	Conditions
TEMPERATURE RANGE						
Operating Ambient Temperature	T_A	0	—	+70	°C	
Storage Temperature	T_S	-65	—	+150	°C	
PACKAGE THERMAL RESISTANCE						
80-lead PQFP	θ_{JA}	—	37	—	°C/W	

Timing Waveforms

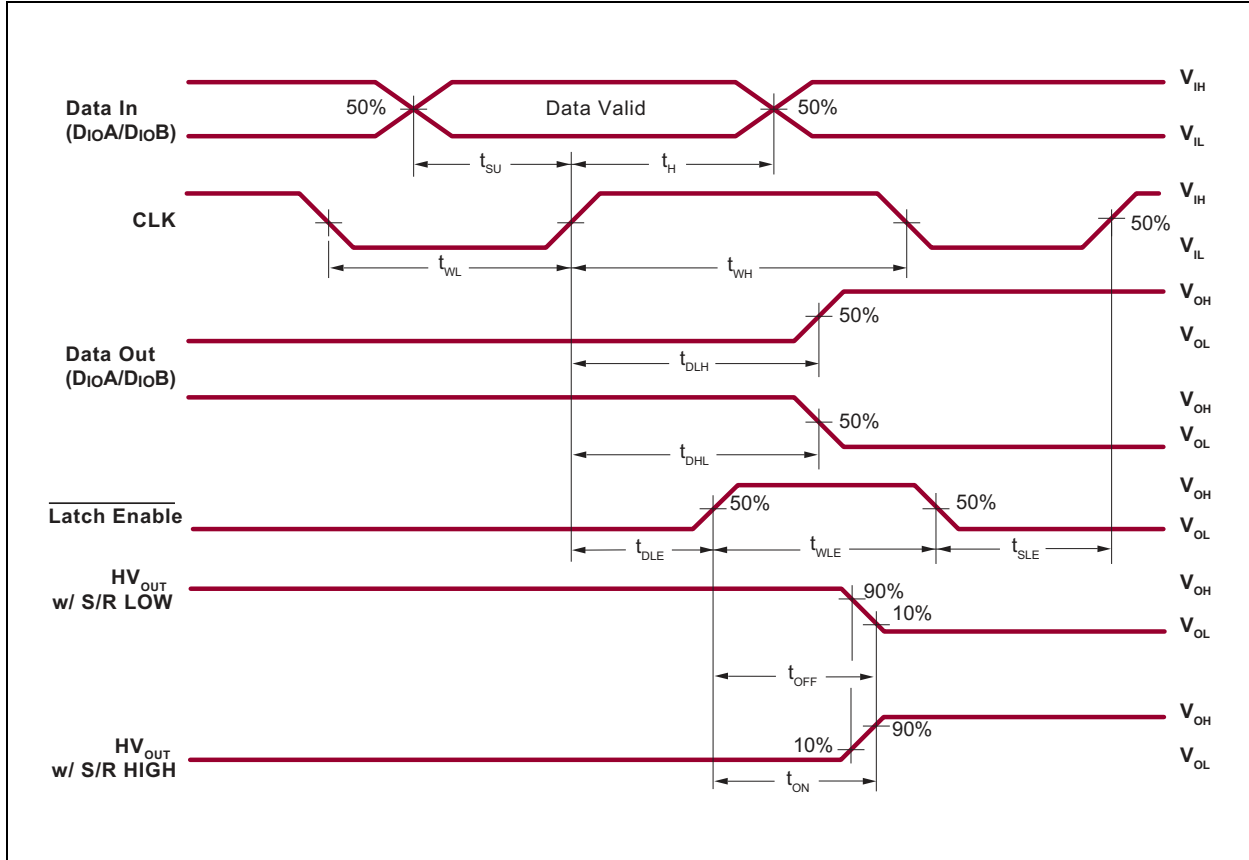

2.0 PIN DESCRIPTION

The details on the pins of HV507 are listed on [Table 2-1](#). Refer to [Package Type](#) for the location of pins.

TABLE 2-1: PIN FUNCTION TABLE

Pin Number	Pin Name	Description
1	HVOUT41	High-voltage output
2	HVOUT42	High-voltage output
3	HVOUT43	High-voltage output
4	HVOUT44	High-voltage output
5	HVOUT45	High-voltage output
6	HVOUT46	High-voltage output
7	HVOUT47	High-voltage output
8	HVOUT48	High-voltage output
9	HVOUT49	High-voltage output
10	HVOUT50	High-voltage output
11	HVOUT51	High-voltage output
12	HVOUT52	High-voltage output
13	HVOUT53	High-voltage output
14	HVOUT54	High-voltage output
15	HVOUT55	High-voltage output
16	HVOUT56	High-voltage output
17	HVOUT57	High-voltage output
18	HVOUT58	High-voltage output
19	HVOUT59	High-voltage output
20	HVOUT60	High-voltage output
21	HVOUT61	High-voltage output
22	HVOUT62	High-voltage output
23	HVOUT63	High-voltage output
24	HVOUT64	High-voltage output
25	VPP	High-voltage power supply
26	DIOA	Serial Data Input/Output A
27	NC	No connection
28	NC	No connection
29	$\overline{\text{BL}}$	Blanking
30	$\overline{\text{POL}}$	Polarity
31	VDD	Low-voltage power supply
32	DIR	Direction
33	GND	Logic voltage ground
34	HVGND	High-voltage power supply
35	NC	No connection
36	NC	No connection

HV507

TABLE 2-1: PIN FUNCTION TABLE (CONTINUED)

Pin Number	Pin Name	Description
37	CLK	Data Shift Register Clock. Inputs are shifted into the Shift register on the positive edge of the clock.
38	$\overline{\text{LE}}$	Latch Enable
39	DIOB	Serial Data Input/Output B
40	VPP	High-voltage power supply
41	HVOUT1	High-voltage output
42	HVOUT2	High-voltage output
43	HVOUT3	High-voltage output
44	HVOUT4	High-voltage output
45	HVOUT5	High-voltage output
46	HVOUT6	High-voltage output
47	HVOUT7	High-voltage output
48	HVOUT8	High-voltage output
49	HVOUT9	High-voltage output
50	HVOUT10	High-voltage output
51	HVOUT11	High-voltage output
52	HVOUT12	High-voltage output
53	HVOUT13	High-voltage output
54	HVOUT14	High-voltage output
55	HVOUT15	High-voltage output
56	HVOUT16	High-voltage output
57	HVOUT17	High-voltage output
58	HVOUT18	High-voltage output
59	HVOUT19	High-voltage output
60	HVOUT20	High-voltage output
61	HVOUT21	High-voltage output
62	HVOUT22	High-voltage output
63	HVOUT23	High-voltage output
64	HVOUT24	High-voltage output
65	HVOUT25	High-voltage output
66	HVOUT26	High-voltage output
67	HVOUT27	High-voltage output
68	HVOUT28	High-voltage output
69	HVOUT29	High-voltage output
70	HVOUT30	High-voltage output
71	HVOUT31	High-voltage output
72	HVOUT32	High-voltage output
73	HVOUT33	High-voltage output
74	HVOUT34	High-voltage output
75	HVOUT35	High-voltage output
76	HVOUT36	High-voltage output

TABLE 2-1: PIN FUNCTION TABLE (CONTINUED)

Pin Number	Pin Name	Description
77	HVOUT37	High-voltage output
78	HVOUT38	High-voltage output
79	HVOUT39	High-voltage output
80	HVOUT40	High-voltage output

HV507

3.0 FUNCTIONAL DESCRIPTION

Follow the steps in [Table 3-1](#) to power up and power down the HV507.

TABLE 3-1: POWER-UP AND POWER-DOWN SEQUENCE

Power-up		Power-down	
Step	Description	Step	Description
1	Connect ground.	1	Remove V_{PP} . (Note 1)
2	Apply V_{DD} .	2	Remove all inputs.
3	Set all inputs (Data, CLK, Enable, etc.) to a known state.	3	Remove V_{DD} .
4	Apply V_{PP} . (Note 1)	4	Disconnect ground.

Note 1: The V_{PP} should not drop below V_{DD} or float during operation.

TABLE 3-2: TRUTH FUNCTION TABLE

Function	Inputs						Outputs				
	Data	CLK	\overline{LE}	\overline{BL}	\overline{POL}	DIR	Shift Register		High-voltage Output		Data Out
							1	2...64	1	2...64	*
All On	X	X	X	L	L	X	*	*...*	H	H...H	*
All Off	X	X	X	L	H	X	*	*...*	L	L...L	*
Invert Mode	X	X	L	H	L	X	*	*...*	$\overline{*}$	$\overline{*...*}$	*
Load S/R	H or L	\uparrow	L	H	H	X	H or L	*...*	*	*...*	*
Store Data in Latches	X	X	\downarrow	H	H	X	*	*...*	*	*...*	*
	X	X	\downarrow	H	L	X	*	*...*	$\overline{*}$	$\overline{*...*}$	*
Transparent Latch Mode	L	\uparrow	H	H	H	X	L	*...*	L	*...*	*
	H	\uparrow	H	H	H	X	H	*...*	H	*...*	*
I/O Relation	D_{IOA}	\uparrow	X	X	X	L	$Q_N \rightarrow$	Q_{N+1}	—	—	D_{IOB}
	D_{IOB}	\uparrow	X	X	X	H	$Q_N \rightarrow$	Q_{N+1}	—	—	D_{IOA}

Note: H = High-logic level
 L = Low-logic level
 X = Irrelevant
 \uparrow = Low-to-high transition
 \downarrow = High-to-low transition
 * = Dependent on the previous stage's state before the last CLK or last \overline{LE} high

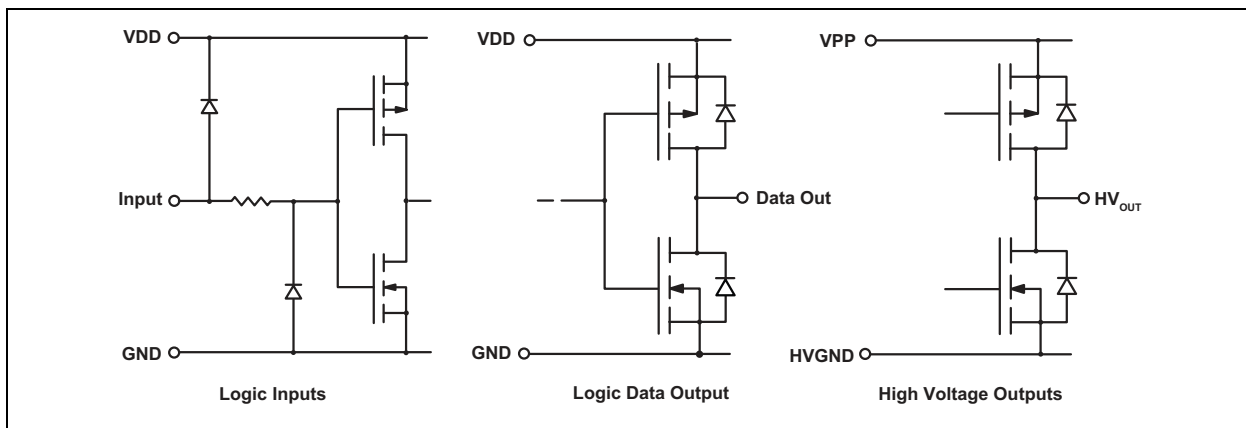
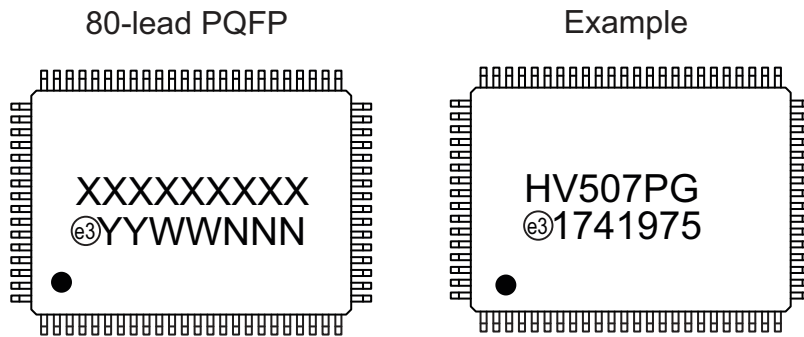

FIGURE 3-1: Input and Output Equivalent Circuits.

4.0 PACKAGE MARKING INFORMATION

4.1 Packaging Information



Legend:	XX...X	Product Code or Customer-specific information
	Y	Year code (last digit of calendar year)
	YY	Year code (last 2 digits of calendar year)
	WW	Week code (week of January 1 is week '01')
	NNN	Alphanumeric traceability code
	e3	Pb-free JEDEC® designator for Matte Tin (Sn)
	*	This package is Pb-free. The Pb-free JEDEC designator (e3) can be found on the outer packaging for this package.
Note:	In the event the full Microchip part number cannot be marked on one line, it will be carried over to the next line, thus limiting the number of available characters for product code or customer-specific information. Package may or not include the corporate logo.	

80-Lead PQFP Package Outline (PG)

20.00x14.00mm body, 3.40mm height (max), 0.80mm pitch, 3.90mm footprint

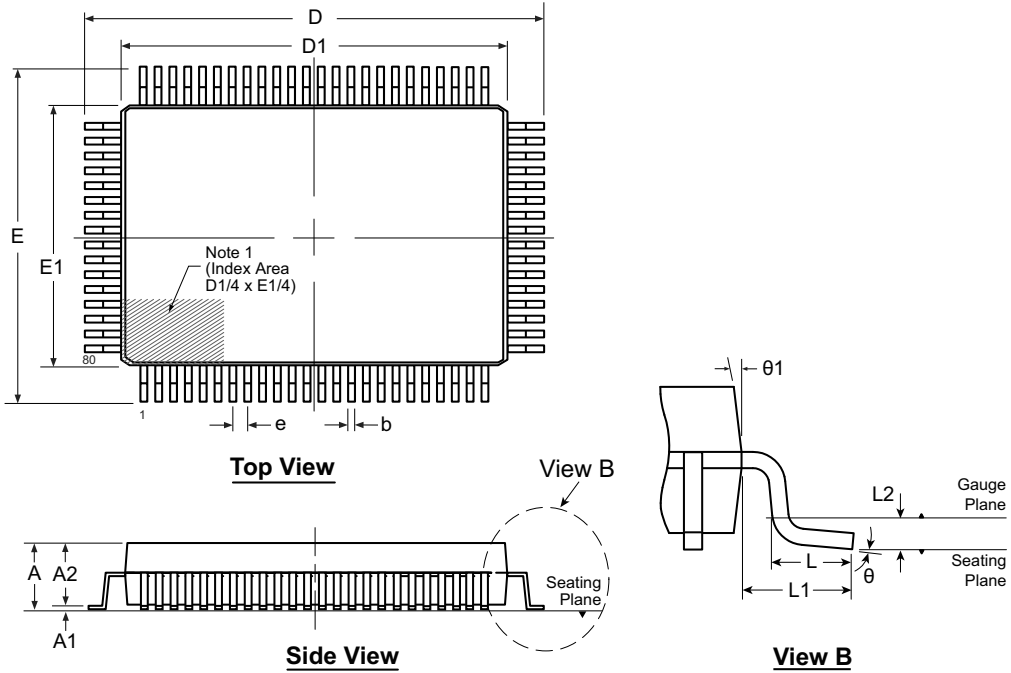

Note: For the most current package drawings, see the Microchip Packaging Specification at www.microchip.com/packaging.

Note:

1. A Pin 1 identifier must be located in the index area indicated. The Pin 1 identifier can be: a molded mark/identifier; an embedded metal marker; or a printed indicator.

Symbol	A	A1	A2	b	D	D1	E	E1	e	L	L1	L2	θ	$\theta 1$	
Dimension (mm)	MIN	2.80*	0.25	2.55	0.30	23.65*	19.80*	17.65*	13.80*	0.80 BSC	0.73	1.95 REF	0.25 BSC	0°	5°
	NOM	-	-	2.80	-	23.90	20.00	17.90	14.00		0.88			3.5°	-
	MAX	3.40	0.50*	3.05	0.45	24.15*	20.20*	18.15*	14.20*		1.03			7°	16°

JEDEC Registration MO-112, Variation CB-1, Issue B, Sept. 1995.

* This dimension is not specified in the JEDEC drawing.

Drawings not to scale.

APPENDIX A: REVISION HISTORY

Revision A (October 2017)

- Converted Supertex Doc # DSFP-HV507 to Microchip DS20005845A
- Removed “Processed with HVCMOS® Technology” in the Features section
- Changed the package marking format
- Changed the quantity of the 80-lead PQFP PG package from 1000/Reel to 66/Tray
- Made minor changes throughout the document

HV507

PRODUCT IDENTIFICATION SYSTEM

To order or obtain information, e.g., on pricing or delivery, contact your local Microchip representative or sales office.

<u>PART NO.</u>	<u>XX</u>	-	<u>X</u>	-	<u>X</u>
Device	Package Options		Environmental		Media Type
Device:	HV507	=	64-Channel Serial-to-Parallel Converter with High-Voltage Push-Pull Outputs		
Package:	PG	=	80-lead PQFP		
Environmental:	G	=	Lead (Pb)-free/RoHS-compliant Package		
Media Type:	(blank)	=	66/Tray for a PG Package		

Example:

a) HV507PG-G: 64-Channel Serial-to-Parallel Converter with High-Voltage Push-Pull Outputs, 80-lead PQFP, 66/Tray

Note the following details of the code protection feature on Microchip devices:

- Microchip products meet the specification contained in their particular Microchip Data Sheet.
- Microchip believes that its family of products is one of the most secure families of its kind on the market today, when used in the intended manner and under normal conditions.
- There are dishonest and possibly illegal methods used to breach the code protection feature. All of these methods, to our knowledge, require using the Microchip products in a manner outside the operating specifications contained in Microchip's Data Sheets. Most likely, the person doing so is engaged in theft of intellectual property.
- Microchip is willing to work with the customer who is concerned about the integrity of their code.
- Neither Microchip nor any other semiconductor manufacturer can guarantee the security of their code. Code protection does not mean that we are guaranteeing the product as “unbreakable.”

Code protection is constantly evolving. We at Microchip are committed to continuously improving the code protection features of our products. Attempts to break Microchip's code protection feature may be a violation of the Digital Millennium Copyright Act. If such acts allow unauthorized access to your software or other copyrighted work, you may have a right to sue for relief under that Act.

Information contained in this publication regarding device applications and the like is provided only for your convenience and may be superseded by updates. It is your responsibility to ensure that your application meets with your specifications. MICROCHIP MAKES NO REPRESENTATIONS OR WARRANTIES OF ANY KIND WHETHER EXPRESS OR IMPLIED, WRITTEN OR ORAL, STATUTORY OR OTHERWISE, RELATED TO THE INFORMATION, INCLUDING BUT NOT LIMITED TO ITS CONDITION, QUALITY, PERFORMANCE, MERCHANTABILITY OR FITNESS FOR PURPOSE. Microchip disclaims all liability arising from this information and its use. Use of Microchip devices in life support and/or safety applications is entirely at the buyer's risk, and the buyer agrees to defend, indemnify and hold harmless Microchip from any and all damages, claims, suits, or expenses resulting from such use. No licenses are conveyed, implicitly or otherwise, under any Microchip intellectual property rights unless otherwise stated.

Microchip received ISO/TS-16949:2009 certification for its worldwide headquarters, design and wafer fabrication facilities in Chandler and Tempe, Arizona; Gresham, Oregon and design centers in California and India. The Company's quality system processes and procedures are for its PIC® MCUs and dsPIC® DSCs, KEELOQ® code hopping devices, Serial EEPROMs, microperipherals, nonvolatile memory and analog products. In addition, Microchip's quality system for the design and manufacture of development systems is ISO 9001:2000 certified.

**QUALITY MANAGEMENT SYSTEM
CERTIFIED BY DNV
= ISO/TS 16949 =**

Trademarks

The Microchip name and logo, the Microchip logo, AnyRate, AVR, AVR logo, AVR Freaks, BeaconThings, BitCloud, CryptoMemory, CryptoRF, dsPIC, FlashFlex, flexPWR, Helder, JukeBlox, KEELOQ, KEELOQ logo, Klear, LANCheck, LINK MD, maXStylus, maXTouch, MediaLB, megaAVR, MOST, MOST logo, MPLAB, OptoLyzer, PIC, picoPower, PICSTART, PIC32 logo, Prochip Designer, QTouch, RightTouch, SAM-BA, SpyNIC, SST, SST Logo, SuperFlash, tinyAVR, UNI/O, and XMEGA are registered trademarks of Microchip Technology Incorporated in the U.S.A. and other countries.

ClockWorks, The Embedded Control Solutions Company, EtherSynch, Hyper Speed Control, HyperLight Load, IntelliMOS, mTouch, Precision Edge, and Quiet-Wire are registered trademarks of Microchip Technology Incorporated in the U.S.A.

Adjacent Key Suppression, AKS, Analog-for-the-Digital Age, Any Capacitor, AnyIn, AnyOut, BodyCom, chipKIT, chipKIT logo, CodeGuard, CryptoAuthentication, CryptoCompanion, CryptoController, dsPICDEM, dsPICDEM.net, Dynamic Average Matching, DAM, ECAN, EtherGREEN, In-Circuit Serial Programming, ICSP, Inter-Chip Connectivity, JitterBlocker, KlearNet, KlearNet logo, Mindi, MiWi, motorBench, MPASM, MPF, MPLAB Certified logo, MPLIB, MPLINK, MultiTRAK, NetDetach, Omniscient Code Generation, PICDEM, PICDEM.net, PICKit, PICTail, PureSilicon, QMatrix, RightTouch logo, REAL ICE, Ripple Blocker, SAM-ICE, Serial Quad I/O, SMART-I.S., SQI, SuperSwitcher, SuperSwitcher II, Total Endurance, TSHARC, USBCheck, VariSense, ViewSpan, WiperLock, Wireless DNA, and ZENA are trademarks of Microchip Technology Incorporated in the U.S.A. and other countries.

SQTP is a service mark of Microchip Technology Incorporated in the U.S.A.

Silicon Storage Technology is a registered trademark of Microchip Technology Inc. in other countries.

GestIC is a registered trademark of Microchip Technology Germany II GmbH & Co. KG, a subsidiary of Microchip Technology Inc., in other countries.

All other trademarks mentioned herein are property of their respective companies.

© 2017, Microchip Technology Incorporated, All Rights Reserved.
ISBN: 978-1-5224-2262-4



MICROCHIP

Worldwide Sales and Service

AMERICAS

Corporate Office
2355 West Chandler Blvd.
Chandler, AZ 85224-6199
Tel: 480-792-7200
Fax: 480-792-7277
Technical Support:
<http://www.microchip.com/support>
Web Address:
www.microchip.com

Atlanta
Duluth, GA
Tel: 678-957-9614
Fax: 678-957-1455

Austin, TX
Tel: 512-257-3370

Boston
Westborough, MA
Tel: 774-760-0087
Fax: 774-760-0088

Chicago
Itasca, IL
Tel: 630-285-0071
Fax: 630-285-0075

Dallas
Addison, TX
Tel: 972-818-7423
Fax: 972-818-2924

Detroit
Novi, MI
Tel: 248-848-4000

Houston, TX
Tel: 281-894-5983

Indianapolis
Noblesville, IN
Tel: 317-773-8323
Fax: 317-773-5453
Tel: 317-536-2380

Los Angeles
Mission Viejo, CA
Tel: 949-462-9523
Fax: 949-462-9608
Tel: 951-273-7800

Raleigh, NC
Tel: 919-844-7510

New York, NY
Tel: 631-435-6000

San Jose, CA
Tel: 408-735-9110
Tel: 408-436-4270

Canada - Toronto
Tel: 905-695-1980
Fax: 905-695-2078

ASIA/PACIFIC

Asia Pacific Office
Suites 3707-14, 37th Floor
Tower 6, The Gateway
Harbour City, Kowloon

Hong Kong
Tel: 852-2943-5100
Fax: 852-2401-3431

Australia - Sydney
Tel: 61-2-9868-6733
Fax: 61-2-9868-6755

China - Beijing
Tel: 86-10-8569-7000
Fax: 86-10-8528-2104

China - Chengdu
Tel: 86-28-8665-5511
Fax: 86-28-8665-7889

China - Chongqing
Tel: 86-23-8980-9588
Fax: 86-23-8980-9500

China - Dongguan
Tel: 86-769-8702-9880

China - Guangzhou
Tel: 86-20-8755-8029

China - Hangzhou
Tel: 86-571-8792-8115
Fax: 86-571-8792-8116

China - Hong Kong SAR
Tel: 852-2943-5100
Fax: 852-2401-3431

China - Nanjing
Tel: 86-25-8473-2460
Fax: 86-25-8473-2470

China - Qingdao
Tel: 86-532-8502-7355
Fax: 86-532-8502-7205

China - Shanghai
Tel: 86-21-3326-8000
Fax: 86-21-3326-8021

China - Shenyang
Tel: 86-24-2334-2829
Fax: 86-24-2334-2393

China - Shenzhen
Tel: 86-755-8864-2200
Fax: 86-755-8203-1760

China - Wuhan
Tel: 86-27-5980-5300
Fax: 86-27-5980-5118

China - Xian
Tel: 86-29-8833-7252
Fax: 86-29-8833-7256

ASIA/PACIFIC

China - Xiamen
Tel: 86-592-2388138
Fax: 86-592-2388130

China - Zhuhai
Tel: 86-756-3210040
Fax: 86-756-3210049

India - Bangalore
Tel: 91-80-3090-4444
Fax: 91-80-3090-4123

India - New Delhi
Tel: 91-11-4160-8631
Fax: 91-11-4160-8632

India - Pune
Tel: 91-20-3019-1500

Japan - Osaka
Tel: 81-6-6152-7160
Fax: 81-6-6152-9310

Japan - Tokyo
Tel: 81-3-6880-3770
Fax: 81-3-6880-3771

Korea - Daegu
Tel: 82-53-744-4301
Fax: 82-53-744-4302

Korea - Seoul
Tel: 82-2-554-7200
Fax: 82-2-558-5932 or
82-2-558-5934

Malaysia - Kuala Lumpur
Tel: 60-3-6201-9857
Fax: 60-3-6201-9859

Malaysia - Penang
Tel: 60-4-227-8870
Fax: 60-4-227-4068

Philippines - Manila
Tel: 63-2-634-9065
Fax: 63-2-634-9069

Singapore
Tel: 65-6334-8870
Fax: 65-6334-8850

Taiwan - Hsin Chu
Tel: 886-3-5778-366
Fax: 886-3-5770-955

Taiwan - Kaohsiung
Tel: 886-7-213-7830

Taiwan - Taipei
Tel: 886-2-2508-8600
Fax: 886-2-2508-0102

Thailand - Bangkok
Tel: 66-2-694-1351
Fax: 66-2-694-1350

EUROPE

Austria - Wels
Tel: 43-7242-2244-39
Fax: 43-7242-2244-393

Denmark - Copenhagen
Tel: 45-4450-2828
Fax: 45-4485-2829

Finland - Espoo
Tel: 358-9-4520-820

France - Paris
Tel: 33-1-69-53-63-20
Fax: 33-1-69-30-90-79

Germany - Garching
Tel: 49-8931-9700

Germany - Haan
Tel: 49-2129-3766400

Germany - Heilbronn
Tel: 49-7131-67-3636

Germany - Karlsruhe
Tel: 49-721-625370

Germany - Munich
Tel: 49-89-627-144-0
Fax: 49-89-627-144-44

Germany - Rosenheim
Tel: 49-8031-354-560

Israel - Ra'anana
Tel: 972-9-744-7705

Italy - Milan
Tel: 39-0331-742611
Fax: 39-0331-466781

Italy - Padova
Tel: 39-049-7625286

Netherlands - Drunen
Tel: 31-416-690399
Fax: 31-416-690340

Norway - Trondheim
Tel: 47-7289-7561

Poland - Warsaw
Tel: 48-22-3325737

Romania - Bucharest
Tel: 40-21-407-87-50

Spain - Madrid
Tel: 34-91-708-08-90
Fax: 34-91-708-08-91

Sweden - Gothenberg
Tel: 46-31-704-60-40

Sweden - Stockholm
Tel: 46-8-5090-4654

UK - Wokingham
Tel: 44-118-921-5800
Fax: 44-118-921-5820