

# OPTION D

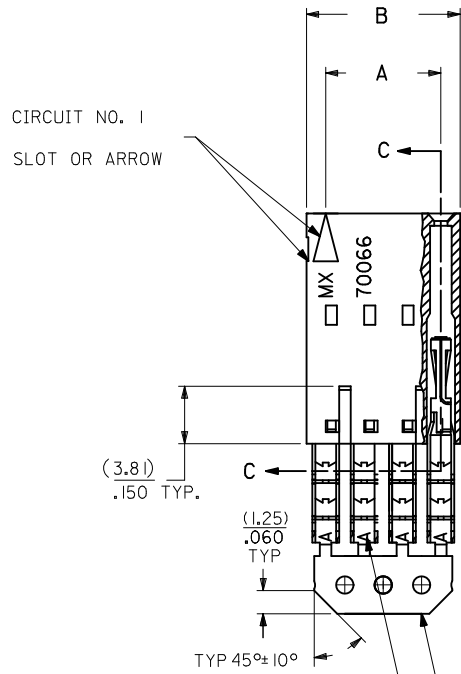

- NOTES:  
 1. MATERIAL:  
 HOUSING: POLYESTER(PBT), GLASS FILLED, UL94 V-0;  
 COLOR: BLACK  
 TERMINAL: PHOSPHOR BRONZE  
 2. FINISH:  
 TIN: 3.81 MICROMETERS/150 MICROINCHES MINIMUM TIN  
 OVER NICKEL UNDERPLATE OVERALL  
 3. TO BE USED WITH 24 AWG STRANDED WIRE WITH (1.35)/.053  
 DIAMETER MAXIMUM INSULATION  
 4. SEE TABLE FOR AVAILABLE CIRCUIT SIZES  
 5. STANDARD PACKAGING PER PK-70873-0001. OPTIONAL PACKAGING  
 MAY BE AVAILABLE, REQUEST DRAWING PK-70400  
 6. PARTS STACKABLE END TO END ON (2.54)/.100 CENTERS  
 7. PRODUCT SPECIFICATION: PS-70400  
 8. SEE DRAWING SDA-70400-\*\*\*\* (SHEET 3) FOR OPTIONAL  
 HOUSING DETAILS  
 9. 4 CIRCUIT SHOWN. 3-25 CIRCUITS HAVE 2 RIBS  
 10. TO MATE WITH MOLEX PART NUMBERS: 70004-\*\*\*\* & 70013-\*\*\*\*  
 11. 2 CIRCUIT ASSEMBLIES SUPPLIED AS GROUPED PAIRS

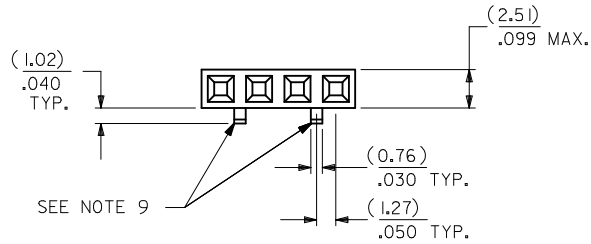
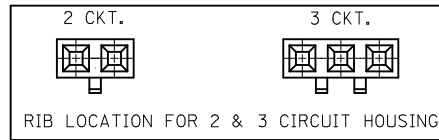

## SECTION C-C

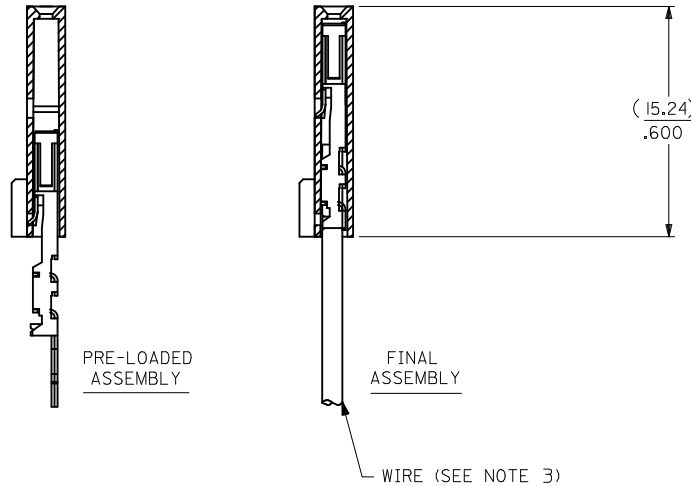

CKT. SIZE	A	B	EDP. NO.
2	( 2.54 ) .100	( 5.05 ) .199	14-60-0028
3	( 5.08 ) .200	( 7.59 ) .299	14-60-0038
4	( 7.62 ) .300	( 10.13 ) .399	14-60-0048
5	( 10.16 ) .400	( 12.67 ) .499	14-60-0058
6	( 12.70 ) .500	( 15.21 ) .599	14-60-0068
7	( 15.24 ) .600	( 17.75 ) .699	14-60-0078
8	( 17.78 ) .700	( 20.29 ) .799	14-60-0088
9	( 20.32 ) .800	( 22.83 ) .899	14-60-0098
10	( 22.86 ) .900	( 25.37 ) .999	14-60-0108
11	( 25.54 ) 1.000	( 27.91 ) 1.099	14-60-0118
12	( 27.94 ) 1.100	( 30.45 ) 1.199	14-60-0128
13	( 30.48 ) 1.200	( 32.99 ) 1.299	14-60-0138
14	( 33.02 ) 1.300	( 35.53 ) 1.399	14-60-0148
15	( 35.56 ) 1.400	( 38.07 ) 1.499	14-60-0158
16	( 38.01 ) 1.500	( 40.61 ) 1.599	14-60-0168
17	( 40.64 ) 1.600	( 43.15 ) 1.699	14-60-0178
18	( 43.18 ) 1.700	( 45.69 ) 1.799	14-60-0188
19	( 45.72 ) 1.800	( 48.23 ) 1.899	14-60-0198
20	( 48.26 ) 1.900	( 50.77 ) 1.999	14-60-0208
21	( 50.80 ) 2.000	( 53.31 ) 2.099	14-60-0218
22	( 53.34 ) 2.100	( 55.85 ) 2.199	14-60-0228
23	( 55.88 ) 2.200	( 58.39 ) 2.299	14-60-0238
24	( 58.42 ) 2.300	( 60.93 ) 2.399	14-60-0248
25	( 60.96 ) 2.400	( 63.47 ) 2.499	14-60-0258

I.D. SLOT CODE TO WIRE GAUGE CHART	
I.D. SLOT CODE	WIRE GAUGE
A	24 AWG.

PLATING CODE (STRIPE ON CARRIER STRIP)	
PLATING	COLOR
TIN	NONE

REMOVE ENG NO. EC NO: UCP2011-110 DRW:MSIBARRA 2010/10/19 CHKD:JMORGAN 2010/10/19 APPR:SMILLER 2010/11/24	QUALITY SYMBOLS ▽=0 ▽=0 ▽=0	GENERAL TOLERANCES (UNLESS SPECIFIED)		DIMENSION STYLE MM/IN		SCALE	DESIGN UNITS	THIRD ANGLE PROJECTION			
		4 PLACES ± --- ± --- 3 PLACES ± --- ± .010 2 PLACES ± 0.25 ± .014 1 PLACE ± 0.35 ± --- ANGULAR ±1/2°		DRAWN BY DATE MSIBARRA 2010/10/19 CHECKED BY DATE WAZ 1984/10/09 APPROVED BY DATE SMILLER 2010/11/24		INCH		ASSEMBLY, SL CONNECTOR SINGLE ROW 2.54/.100 GRID			
		DRAFT WHERE APPLICABLE MUST REMAIN WITHIN DIMENSIONS		MATERIAL NO. SEE TABLE		DOCUMENT NO. SDA-70400-0071-0094		MOLEX INCORPORATED		SHEET NO. 1 OF 1	
		THIS DRAWING CONTAINS INFORMATION THAT IS PROPRIETARY TO MOLEX INCORPORATED AND SHOULD NOT BE USED WITHOUT WRITTEN PERMISSION									