



Features

- Wide Power Supply Voltage Range
- Short-circuit Protected K-interface, ISO9141 Compatible
- Three Short-circuit Protected 40-mA Open-collector Buffers
- All Low-power Outputs with Built-in 28-V Clamping
- CMOS Compatible Digital Inputs with Hysteresis
- Digital 1-mA Push-pull "RxD" K-line Output
- Channel-specific Over-temperature Switch Off in Event of Short Circuit
- Load-dump Protection and Interference Protection
According to ISO 7637-1/4 (DIN 40839)



Single-ended Bus Transceiver with Triple Buffer

1. Description

The U6812B is a bipolar monolithic K-line bus transceiver designed to provide bi-directional serial communication in automotive diagnostic applications. The standard K-line is ISO 9141 compatible for baud rates up to 250 kBaud.

The IC provides three universally applicable 40-mA open-collector buffers, that can be used for signal decoupling. The U6812B is manufactured using Atmel's bipolar process and fully complies to automotive industry specifications. The U6812B provides an ideal grouping of SO-packaged low-power drivers, thus meeting customers' demand for space-saving and cost-effective circuit board assembly.

U6812B

Figure 1-1. Block Diagram

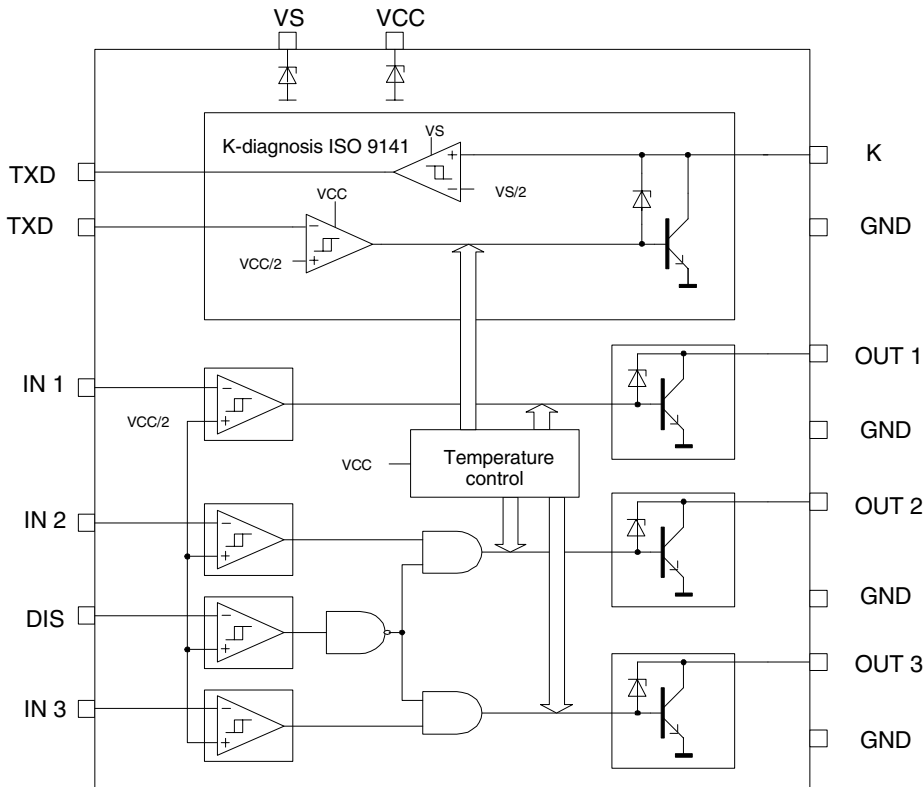

Rev. 4760B-AUTO-10/05



2. Pin Configuration

Figure 2-1. Pinning SO16

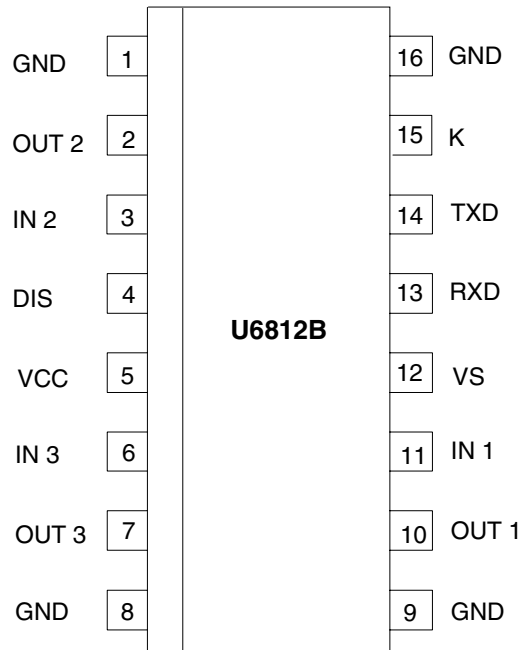
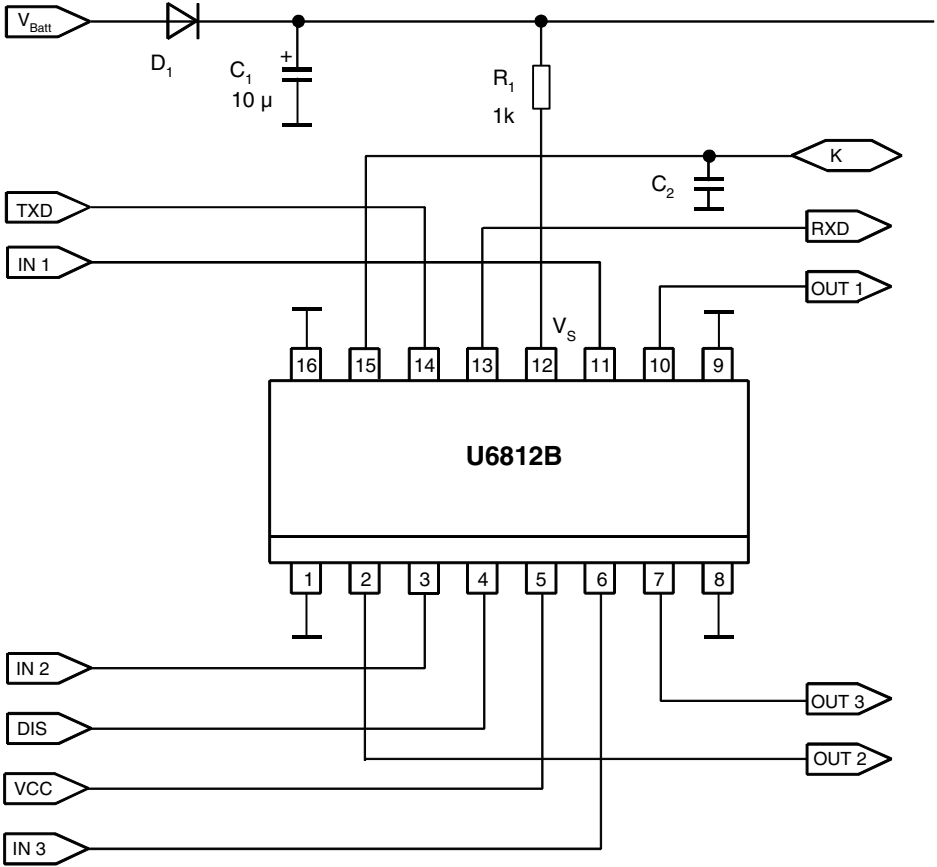

Table 2-1. Pin Description

Pin	Symbol	Type	Function
1	GND	Supply	Ground; all ground pins are directly connected to the lead frame
2	OUT 2	Open-collector output	Protected output of driver 2 (faced to: outside)
3	IN 2	Digital input	Input of protected driver 2 (faced to: μ P)
4	DIS	Digital input	Disable input for OUT 2 and OUT 3, "H" = enable, "L" = disable
5	VCC	Supply	+5-V supply
6	IN 3	Digital input	Input of protected driver 3 (faced to: μ P)
7	OUT 3	Open-collector output	Protected output of driver 3 (faced to: outside)
8	GND	Supply	Ground
9	GND	Supply	Ground
10	OUT 1	Open-collector output	Protected output of driver 1 (faced to: outside)
11	IN 1	Digital input	Input of protected driver 1 (faced to: μ P)
12	VS	Supply/reference	+12-V reference for K-line level
13	RXD	Digital output	Diagnosis receive line (faced to: μ P)
14	TXD	Digital input	Diagnosis transmit line (faced to: μ P)
15	K	12-V input and O.C. output	Bi-directional diagnosis line (faced to: outside)
16	GND	Supply	Ground

Figure 2-2. Basic Application Circuit



3. Functional Description

3.1 K-interface

The K-interface is equipped with a 40-mA open-collector driver. The current is determined by the external pull-up resistor. The saturation voltage is below 0.6V.

The open-collector output is protected by a 28-V Z-diode. The collector current is permanently monitored for short circuits via a built-in shunt. In the event of a short circuit occurring at V_{Batt} , the collector current is held at approximately $I_{\text{creg}} = 80 \text{ mA}$; the chip temperature then rises due to power loss. This status is maintained until the detection of overtemperature which causes the K-line output to be disabled and stored to memory. The internal short-circuit detection threshold is $I_{\text{sc}} > 0.8 \times I_{\text{creg}}$. The output remains disabled until a falling edge of a pulse is available to its input. Any further attempt to connect while the short circuit is still present causes the above sequence to be repeated. The output can be activated normally once the short circuit has been removed. The maximum baud rate is 250 kBaud.

The K-line allows bi-directional communication with the microcontroller. When the output K is disabled, information can be transferred to the processor via the input comparator at pin RxD.

The digital output RxD is a push-pull output stage with a driver power of 1 mA.

In the event of a line break at the K-line, the output K is connected to GND via the built-in 85-k Ω pull-down resistor, thus allowing the microcontroller to detect this fault. The maximum sampling frequency is 250 kBaud.

3.2 Open-collector Driver OUTx

The outputs are designed for a maximum static current of 40 mA, which is determined by the external pull-up resistor. The saturation voltage is below 0.6V.

The three OUTx-driver outputs are activated with “active low” at the corresponding input. Outputs OUT2 and OUT3 can also be disabled with “active low” at the disable input, regardless of their input signal. The outputs are released by an open disable input or by using high potential.

The open-collector outputs are connected to a 28-V Z-diode. The collector current is permanently monitored via a built-in shunt circuit to permit the detection of short circuits. If a short circuit occurs at V_{Batt} , the collector current is held at approximately $I_{\text{creg}} = 80 \text{ mA}$; accompanied with a rise of chip temperature due to power loss. This status is maintained until the detection of overtemperature which causes the output affected by the short circuit to be selectively disabled and stored to memory. The internal short-circuit detection threshold is $I_{\text{sc}} > 0.8 \times I_{\text{creg}}$. The affected output remains disabled until a falling edge of a pulse is available to its input. Any further attempt to connect while the short circuit is still present causes the above sequence to be repeated. The output can be activated normally once the short circuit has been removed.

3.3 Power Supply

The IC must be equipped with external RC circuitry to limit the voltage in the event of power surges (see [Figure 2-2 on page 3](#)). This prevents the circuit from being damaged or destroyed, and provides a buffer in case of power fluctuations at V_{Batt} . The RxD comparator is powered via pin V_S , producing its reference voltage of $1/2 V_S$, while all other blocks are supplied via V_{CC} .

The operating voltage can vary between $V_S = 7\text{V}$ and 26V. The resistor R_1 at pin V_S limits the current via the built-in 28-V Z-diode between V_S and GND.

3.3.1 Application Note

It is recommended to use the external components as shown in [Figure 2-2 on page 3](#) with the reverse battery protection diode D_1 and the buffer capacitor $C_1 = 10 \mu\text{F}$.

3.4 Digital Inputs (DIS, IN 1, IN 2, IN 3 and TxD)

The digital inputs are CMOS-compatible and equipped with a built-in pull-up resistor with a typical rating of $85 \text{ k}\Omega$ to V_{CC} . The input threshold totals $V_{\text{TH}} = 0.57 \times V_{\text{CC}}$ with a typical hysteresis of 100 mV . The inputs are designed for an input voltage of -0.2V to $V_{\text{CC}} + 0.6\text{V}$.

For proper activation of the output stages, it is mandatory that the inputs are kept low as long as the supply voltage is not applied. When the supply voltage has been applied, all inputs need to have a falling edge (see [“Timing Diagrams” on page 6](#)).

3.5 Digital Output (RxD)

The digital output RxD is a push-pull output stage with a driver power of $I_{\text{RxD}} = 1 \text{ mA}$.

3.6 Interference Voltages and Load Dump (Defined in DIN40839 or ISO7637)

The U6812B is protected against interference pulses (usually present in the wiring) by the recommended R_1C_1 circuitry and the integrated elements (28-V Z-diodes, both at the supply pin and at the output pins and two diodes connected to V_{CC} and GND at the digital inputs). All transient pulses, which appear on the supply line (V_{Batt}), should not affect the function of the IC (see [Table 3-1](#)).

Table 3-1. Transient Test Conditions

Name	Voltage	Source Resistance	Rise Time	Pulse Duration	Pulse Amount
DIN/ISO 1	-110V	10Ω	$100\text{V}/\mu\text{s}$	2 ms	15000
DIN/ISO 2	110V	10Ω	$100\text{V}/\mu\text{s}$	0.05 ms	15000
DIN/ISO 3a	-160V	50Ω	$30\text{V}/\text{ns}$	$0.1 \mu\text{s}$	1h (reference to ISO)
DIN/ISO 3b	150V	50Ω	$20\text{V}/\text{ns}$	$0.1 \mu\text{s}$	1h (reference to ISO)
DIN/ISO 5	55V (total)	2Ω	$10\text{V}/\text{ms}$	500 ms	20

Table 3-2. Truth Table

WSI-1	WSI-2	WSI-R	EN	TXD	K	WSO-1	WSO-2	WSO-R	RXD
L	L	X	H	X	X	L	L	X	X
H	H	X	X	X	X	Open	Open	X	X
L	L	X	L	X	X	Open	Open	X	X
X	X	H	X	H	Open	X	X	Open	H
X	X	L	X	L	L	L	X	L	L
X	X	X	X	X	H	X	X	X	H

4. Timing Diagrams

Figure 4-1. IN2/IN3 - Pulse Diagram

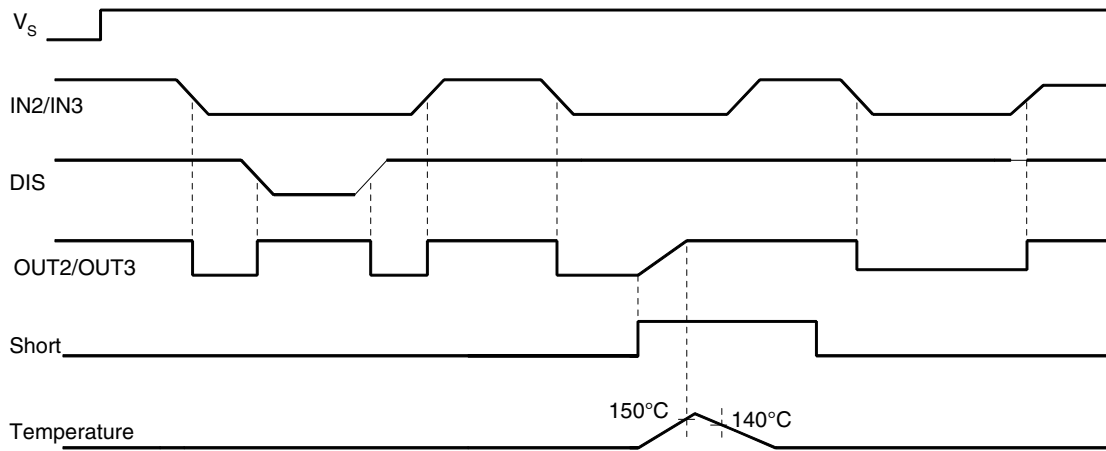

Figure 4-2. IN1 - Pulse Diagram

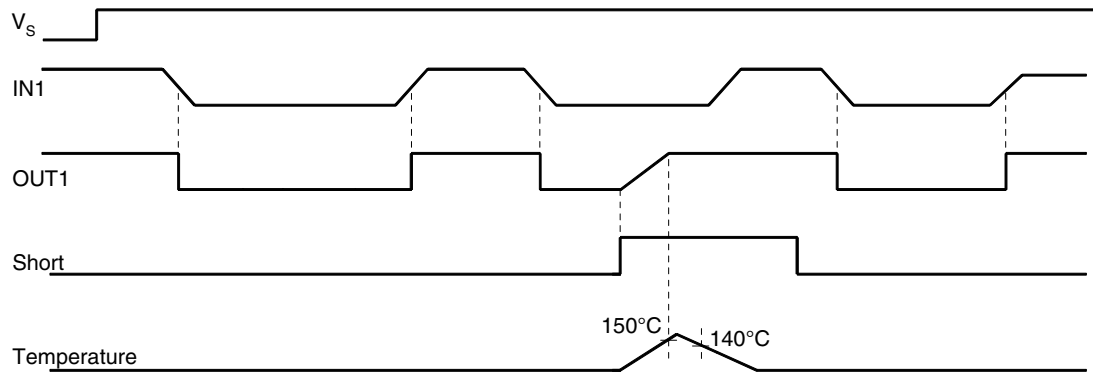
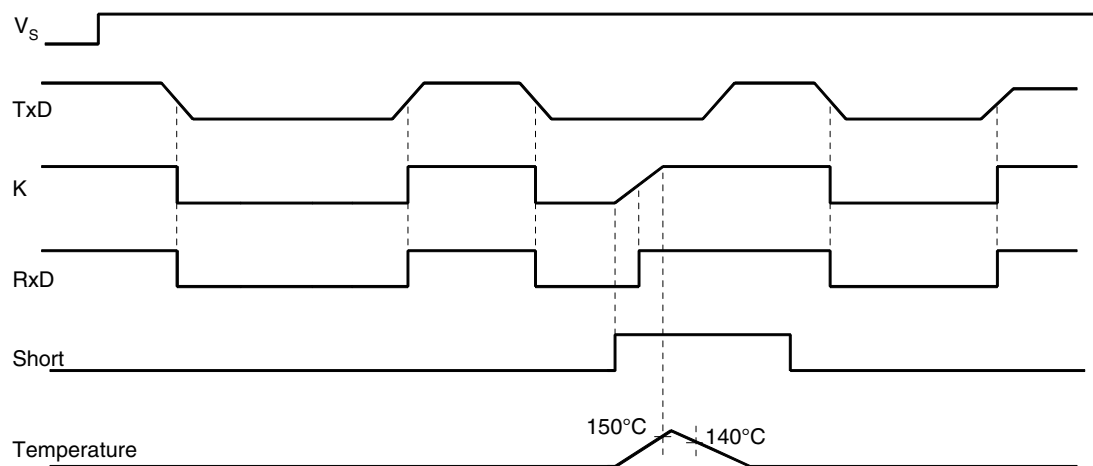

Figure 4-3. K-interface Pulse Diagram



5. Absolute Maximum Ratings

Stresses beyond those listed under “Absolute Maximum Ratings” may cause permanent damage to the device. This is a stress rating only and functional operation of the device at these or any other conditions beyond those indicated in the operational sections of this specification is not implied. Exposure to absolute maximum rating conditions for extended periods may affect device reliability.

Parameters	Symbol	Value	Unit
Operating voltage	V_S	26	V
Operating voltage	V_{CC}	3 to 6	V
Voltage at pins IN1,2,3; RxD, TxD, DIS	V_i	-0.2 to +6	V
Voltage at pins OUT1, 2, 3; K	V_o	-1 to +26	V
Static collector current at pins OUT1,2,3; K	I_x	45	mA
Ambient temperature	T_{amb}	-40 to +125	°C
Storage temperature range	T_{stg}	-55 to +150	°C
Maximum junction temperature	T_j	150	°C

6. Thermal Resistance

Parameters	Symbol	Value	Unit
Junction to case	R_{thJC}	36	K/W
Junction to ambient; strongly depending on the assembly	R_{thJA}	65 to 80	K/W

7. Electrical Characteristics

$T_{amb} = -40$ to $+125^{\circ}\text{C}$, $V_{CC} = 4.75\text{V}$ to 5.25V (unless otherwise specified), reference point is GND (pin 1, 7, 8, 16).
IC with recommended external components (see [Figure 2-2](#) on page 3).

Parameters	Test Conditions	Pin	Symbol	Min.	Typ.	Max.	Unit
Supply 5, 12							
Supply voltage			V_S	7		26	V
Supply voltage			V_{CC}	4.5		5.5	V
Reduced supply voltage	$V_{sat} = 0.6\text{V}$ at $I_X = 20\text{ mA}$		V_{CC}	3.0		4.5	V
Current consumption	All inputs open or high at $V_{CC} = 5.25\text{V}$		I_S			6	mA
	All inputs on (= low) at $V_{CC} = 5.25\text{V}$		I_S			20	mA
Protective resistor			R_1		1		k Ω
Smoothing capacitor			C_1		10		μF
Integrated Z-diode	$I_S = 20\text{ mA}$		V_S	26	28	30	V
Quiescent current	All outputs low or open at $V_S = 18\text{V}$		I_{VS}			0.75	mA
Inputs IN 1, IN 2, IN 3, DIS, TxD 3, 4, 6, 11, 14							
Input voltage			V_i	-0.2		$V_{CC} + 0.6$	V
Internal pull-up resistor			R_i	30	85	170	k Ω
Switchover threshold			V_{ITH}		$0.57 \times V_{CC}$		V
Hysteresis			V_{IHYS}		100		mV
Outputs OUT 1, OUT 2, OUT 3 2, 7, 10							
Integrated Z-diode	$I_{OUTx} = 20\text{ mA}$		V_O	26	28	30	V
Current regulation			I_O	45		130	mA
Saturation voltage	$I_{OUTx} = 40\text{ mA}$		V_{OSAT}			0.6	V
Maximum voltage			V_{out}	-1.0		26	V
Leakage current	Output open, $V_S = 21\text{V}$		I_{Leak}			2	μA
Output RxD 13							
Integrated Z-diode	$I_{RxD} = 20\text{ mA}$		V_{RxD}	26	28	30	V
Output current			I_{RxD}			1	mA
Saturation voltage	$I_{RxD} = 1\text{ mA}$		$V_{RxD SAT}$			0.5	V
Rise time			t_R	0.01		5	μs
Fall time			t_F	0.01		5	μs
K-line 15							
Threshold			V_K		$0.57 \times V_S$		V
Internal pull-down resistor			R_K	30	85	170	k Ω
Integrated Z-diode	$I_K = 20\text{ mA}$		V_K	26	28	30	V
Current regulation			I_K	45		130	mA
Saturation voltage	$I_K = 40\text{ mA}$		V_{Ksat}			0.6	V
Maximum voltage			V_{out}	-1.0		26	V
Maximum baud rate	$I_K = 40\text{ mA}$, $C_2 = 20\text{ nF}$ $C_2 = 470\text{ pF}$			14.4			kBaud
				250			kBaud

8. Ordering Information

Extended Type Number	Package	Remarks
U6812B-MFPG3Y	SO16	Taped and reeled, Pb-free

9. Package Information

Package SO16
Dimensions in mm

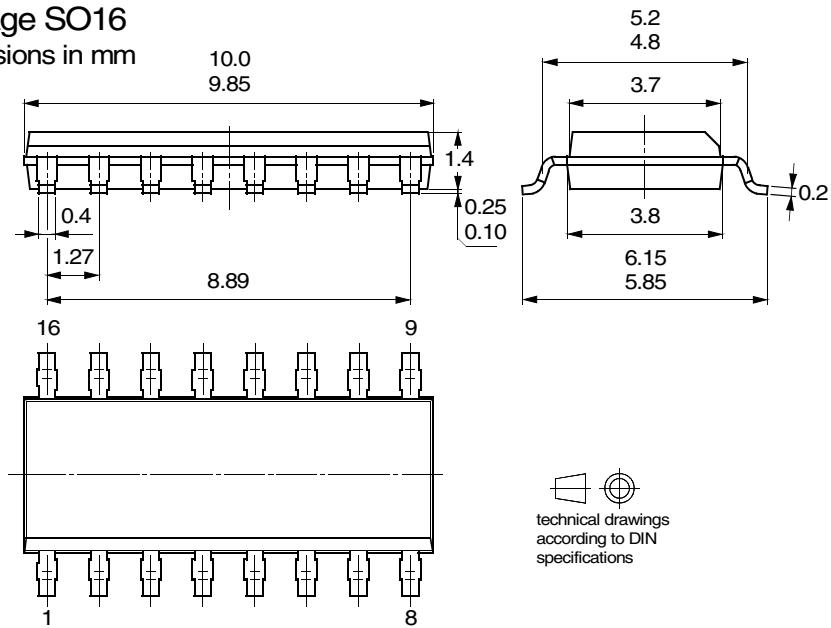

10. Revision History

Please note that the following page numbers referred to in this section refer to the specific revision mentioned, not to this document.

Revision No.	History
4760B-AUTO-10/05	<ul style="list-style-type: none"> Put datasheet in a new template Pb-free logo on page 1 added Table "Ordering Information" on page 9 changed



Atmel Corporation

2325 Orchard Parkway
San Jose, CA 95131, USA
Tel: 1(408) 441-0311
Fax: 1(408) 487-2600

Regional Headquarters

Europe

Atmel Sarl
Route des Arsenaux 41
Case Postale 80
CH-1705 Fribourg
Switzerland
Tel: (41) 26-426-5555
Fax: (41) 26-426-5500

Asia

Room 1219
Chinachem Golden Plaza
77 Mody Road Tsimshatsui
East Kowloon
Hong Kong
Tel: (852) 2721-9778
Fax: (852) 2722-1369

Japan

9F, Tonetsu Shinkawa Bldg.
1-24-8 Shinkawa
Chuo-ku, Tokyo 104-0033
Japan
Tel: (81) 3-3523-3551
Fax: (81) 3-3523-7581

Atmel Operations

Memory

2325 Orchard Parkway
San Jose, CA 95131, USA
Tel: 1(408) 441-0311
Fax: 1(408) 436-4314

Microcontrollers

2325 Orchard Parkway
San Jose, CA 95131, USA
Tel: 1(408) 441-0311
Fax: 1(408) 436-4314

La Chantrerie
BP 70602
44306 Nantes Cedex 3, France
Tel: (33) 2-40-18-18-18
Fax: (33) 2-40-18-19-60

ASIC/ASSP/Smart Cards

Zone Industrielle
13106 Rousset Cedex, France
Tel: (33) 4-42-53-60-00
Fax: (33) 4-42-53-60-01

1150 East Cheyenne Mtn. Blvd.
Colorado Springs, CO 80906, USA
Tel: 1(719) 576-3300
Fax: 1(719) 540-1759

Scottish Enterprise Technology Park
Maxwell Building
East Kilbride G75 0QR, Scotland
Tel: (44) 1355-803-000
Fax: (44) 1355-242-743

RF/Automotive

Theresienstrasse 2
Postfach 3535
74025 Heilbronn, Germany
Tel: (49) 71-31-67-0
Fax: (49) 71-31-67-2340

1150 East Cheyenne Mtn. Blvd.
Colorado Springs, CO 80906, USA
Tel: 1(719) 576-3300
Fax: 1(719) 540-1759

Biometrics/Imaging/Hi-Rel MPU/ High Speed Converters/RF Datacom

Avenue de Rochepleine
BP 123
38521 Saint-Egreve Cedex, France
Tel: (33) 4-76-58-30-00
Fax: (33) 4-76-58-34-80

Literature Requests

www.atmel.com/literature

Disclaimer: The information in this document is provided in connection with Atmel products. No license, express or implied, by estoppel or otherwise, to any intellectual property right is granted by this document or in connection with the sale of Atmel products. **EXCEPT AS SET FORTH IN ATMEL'S TERMS AND CONDITIONS OF SALE LOCATED ON ATMEL'S WEB SITE, ATMEL ASSUMES NO LIABILITY WHATSOEVER AND DISCLAIMS ANY EXPRESS, IMPLIED OR STATUTORY WARRANTY RELATING TO ITS PRODUCTS INCLUDING, BUT NOT LIMITED TO, THE IMPLIED WARRANTY OF MERCHANTABILITY, FITNESS FOR A PARTICULAR PURPOSE, OR NON-INFRINGEMENT. IN NO EVENT SHALL ATMEL BE LIABLE FOR ANY DIRECT, INDIRECT, CONSEQUENTIAL, PUNITIVE, SPECIAL OR INCIDENTAL DAMAGES (INCLUDING, WITHOUT LIMITATION, DAMAGES FOR LOSS OF PROFITS, BUSINESS INTERRUPTION, OR LOSS OF INFORMATION) ARISING OUT OF THE USE OR INABILITY TO USE THIS DOCUMENT, EVEN IF ATMEL HAS BEEN ADVISED OF THE POSSIBILITY OF SUCH DAMAGES.** Atmel makes no representations or warranties with respect to the accuracy or completeness of the contents of this document and reserves the right to make changes to specifications and product descriptions at any time without notice. Atmel does not make any commitment to update the information contained herein. Unless specifically provided otherwise, Atmel products are not suitable for, and shall not be used in, automotive applications. Atmel's products are not intended, authorized, or warranted for use as components in applications intended to support or sustain life.

© Atmel Corporation 2005. All rights reserved. Atmel®, logo and combinations thereof, Everywhere You Are® and others, are registered trademarks or trademarks of Atmel Corporation or its subsidiaries. Other terms and product names may be trademarks of others.



Printed on recycled paper.