

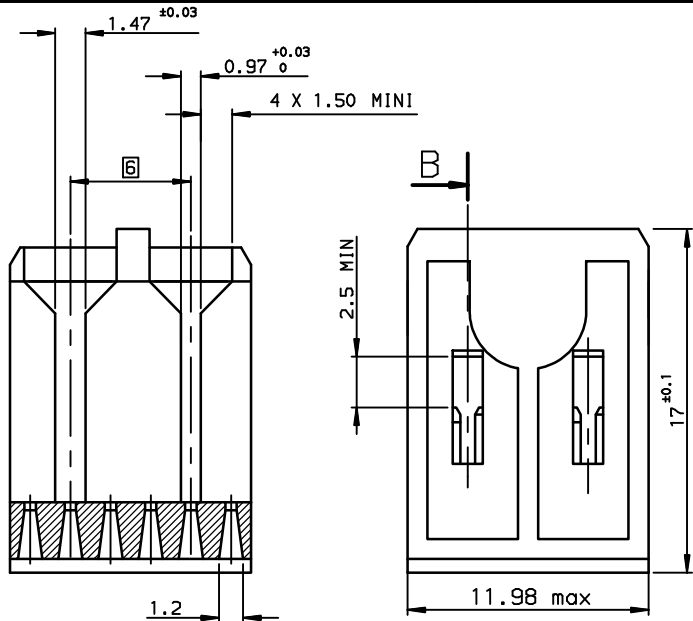

Copyright FCI.

C

D



SECTION-D

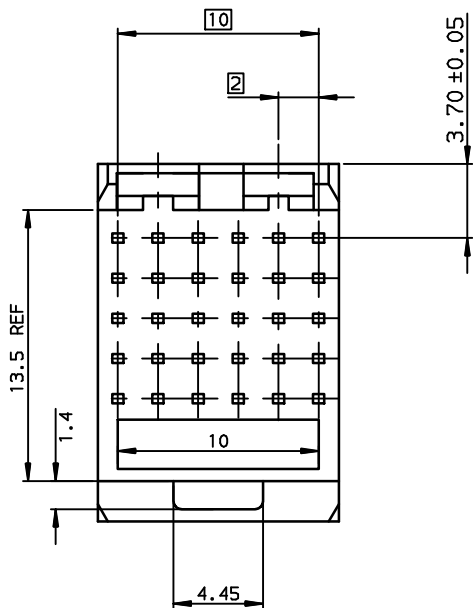

REDUCED SCALE SHEET

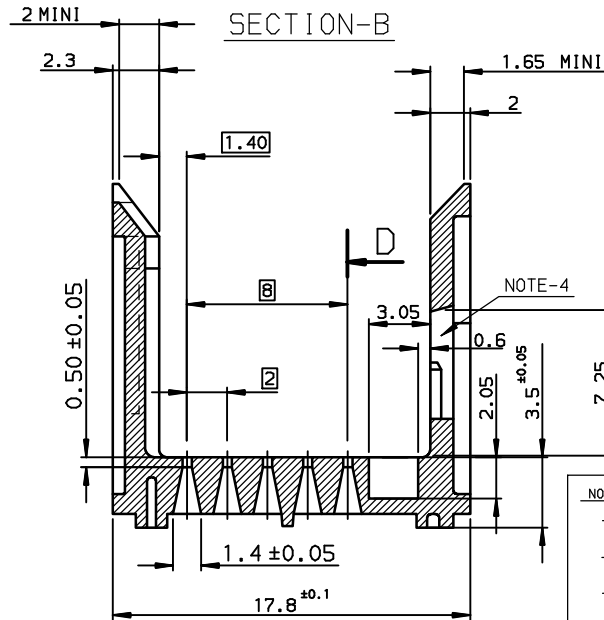

SECTION-B

NOTE: RoHS INFORMATION

- The "LF" product meets European union Directives and other country regulations as described in 65-22-008.
- The product is not intended to be exposed to a manufacturing solder process.
- Packaging spec: see 65-14-920.

- NOTE-1: OTHER DIMENSIONS IN ACCORDANCE WITH IEC-48B-(S.296) SPECIFICATION
- NOTE-2: MATERIAL HIGH TEMPERATURE NATURAL COLOUR (LCP WITHOUT GLASS FIBER)
- NOTE-3: FORCE FIT CAVITIES FOR RETENTION WITH REAR PLUG-UP CONTACT PART
- NOTE-4: CAVITY FOR LATCHING AND CODING

STD VERSION

Part Number: HM13276 OR 52000-111

RoHS COMPATIBLE VERSION

Part Number: HM13276LF OR 52000-111LF

European Views

rev	ecn no	dr	date
B	-	-	-
C	LS05-0038	JTA	2005/04/26
D	LS05-0066	JTA	2005/10/01
E	LS06-0114	LGO	2006/08/09
-	-	-	-
-	-	-	-
-	-	-	-

www.fciconnect.com		surface ISO 1302 ✓	tolerance std ISO 406 ISO 1101	projection mm
TOLERANCES UNLESS OTHERWISE SPECIFIED				
Dr	PERRICHOT	2002/11/19	0.x	±0.1
Eng	TARON	2002/11/19	0.xx	±0.1
Chr	LEGARE	2002/11/19	0.xxx	±0.1
Appr	LEGARE	2002/11/19	Product family METRAL Spec ref -	
title METRAL SHROUD 5 ROWS SPECIF		size A3		Scale 4
catalog no		52000		Rev. E
		CUSTOMER		sheet 1 of 1

REV F - 2006-04-17