

DO NOT SCALE FROM THIS PRINT

PRFM0-J-C-EE-086-SD

SERIES  
-M0: SMPM

GENDER  
-J: JACK

TYPE  
-C: CABLE

FINISH  
-EE: 50μ" EXTRA HEAVY GOLD CENTER CONTACT, 50μ" EXTRA HEAVY GOLD OUTER CONTACT

TERMINATION  
-D: DIRECT SOLDER

ORIENTATION  
-S: STRAIGHT

CABLE TYPE  
-086: TEMP FLEX 1001935086

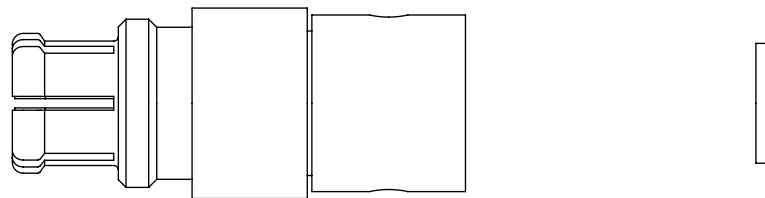
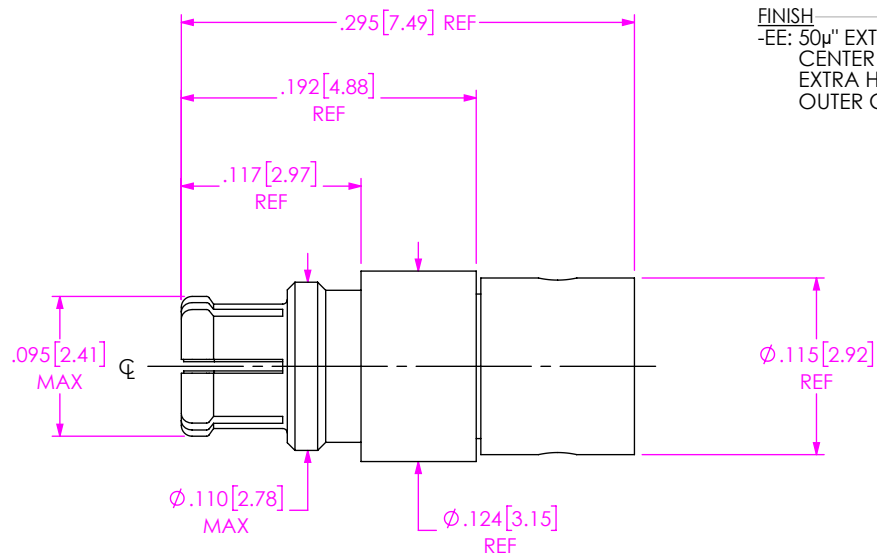

EXPLODED VIEW  
NOT TO SCALE  
(FOR CLARITY ONLY)

NOTES:

- MATERIAL:  
DIELECTRIC STOP: PTFE.  
BEAD: ULTEM.  
SOLDER FERRULE: BRASS ALLOY  
BACK BODY, BODY, CONTACT: BERYLLIUM COPPER.
- FINISH:  
BACK BODY, BODY, CONTACT: GOLD OVER NICKEL PLATE,  
50 μIN MIN GOLD OVER 50 μIN MIN NICKEL.
- PCI P/N: 4127.

<p>UNLESS OTHERWISE SPECIFIED, DIMENSIONS ARE IN INCHES. TOLERANCES ARE: DECIMALS                      ANGLES .XX: ±.01                        1° .XXX: ±.005 .XXXX: ±.0005</p>	<p><b>PROPRIETARY NOTE</b> THIS DOCUMENT CONTAINS CONFIDENTIAL AND PROPRIETARY INFORMATION AND ALL DESIGN, MANUFACTURING, REPRODUCTION, USE, PATENT RIGHTS AND SALES RIGHTS ARE EXPRESSLY RESERVED BY SAMTEC, INC. THIS DOCUMENT SHALL NOT BE DISCLOSED, IN WHOLE OR PART, TO ANY UNAUTHORIZED PERSON OR ENTITY NOR REPRODUCED, TRANSFERRED OR INCORPORATED IN ANY OTHER PROJECT IN ANY MANNER WITHOUT THE EXPRESS WRITTEN CONSENT OF SAMTEC, INC.</p>	 <p>520 PARK EAST BLVD., NEW ALBANY, IN 47150 PHONE: 812-944-6733    FAX: 812-948-5047 e-Mail: info@SAMTEC.com    code 55322</p>
<p>DO NOT SCALE DRAWING</p>	<p>SHEET SCALE: 8:1</p>	<p>DESCRIPTION: SMPM SOCKET, DIRECT SOLDER FOR TEMP FLEX 1001935086 DWG. NO. <b>PRFM0-J-C-EE-086-SD</b> BY: ADAM H.    10/24/2019    SHEET 1 OF 2</p>

# CABLE APPLICATION VIEWS

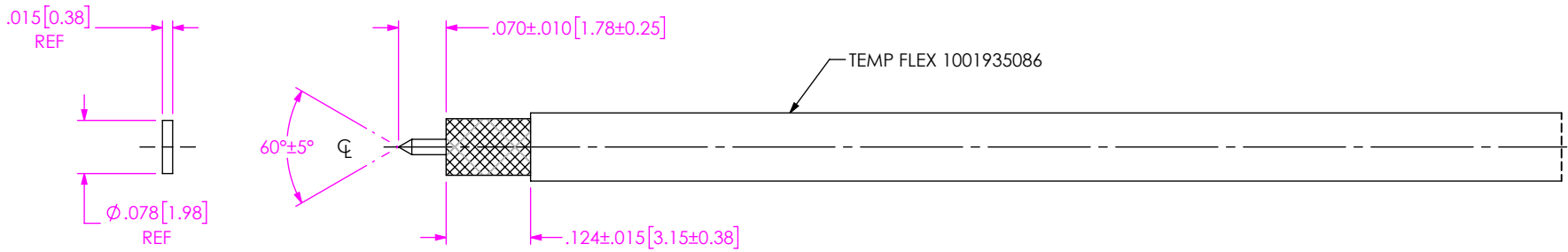

- 1A. TRIM CABLE TO EXPOSE OUTER BRAID AND CENTER CONDUCTOR AS SHOWN.
- 1B. POINT CENTER CONDUCTOR AS SHOWN.

IN-PROCESS VIEW 1

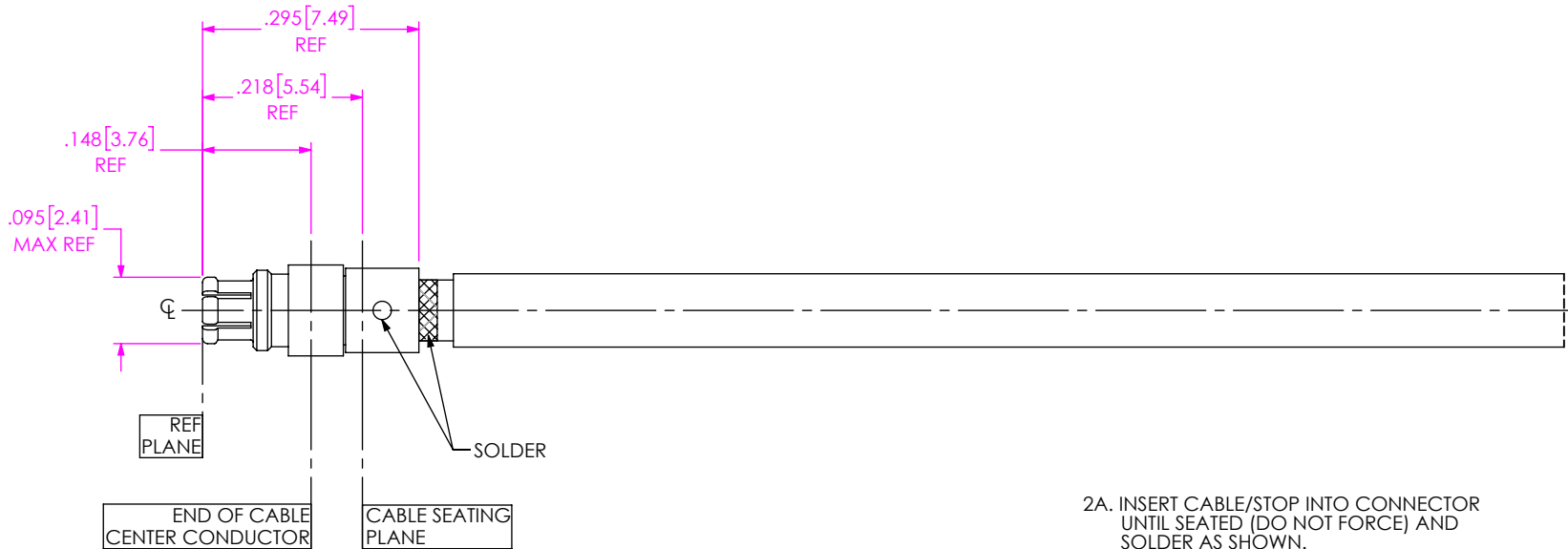

- 2A. INSERT CABLE/STOP INTO CONNECTOR UNTIL SEATED (DO NOT FORCE) AND SOLDER AS SHOWN.

IN-PROCESS VIEW 2

**PROPRIETARY NOTE**  
 THIS DOCUMENT CONTAINS CONFIDENTIAL AND PROPRIETARY INFORMATION AND ALL DESIGN, MANUFACTURING, REPRODUCTION, USE, PATENT RIGHTS AND SALES RIGHTS ARE EXPRESSLY RESERVED BY SAMTEC, INC. THIS DOCUMENT SHALL NOT BE DISCLOSED, IN WHOLE OR PART, TO ANY UNAUTHORIZED PERSON OR ENTITY NOR REPRODUCED, TRANSFERRED OR INCORPORATED IN ANY OTHER PROJECT IN ANY MANNER WITHOUT THE EXPRESS WRITTEN CONSENT OF SAMTEC, INC.



520 PARK EAST BLVD, NEW ALBANY, IN 47150  
 PHONE: 812-944-6733 FAX: 812-948-5047  
 e-Mail info@SAMTEC.com code 55322

DO NOT SCALE DRAWING

SHEET SCALE: 4:1

DESCRIPTION: SMPM SOCKET, DIRECT SOLDER FOR TEMP FLEX 1001935086

DWG. NO. PRFM0-J-C-EE-086-SD

BY: ADAM H. 10/24/2019 SHEET 2 OF 2