

REVISION F

DO NOT SCALE FROM THIS PRINT

IP5-XX-01-X-X-RA1-X-XR

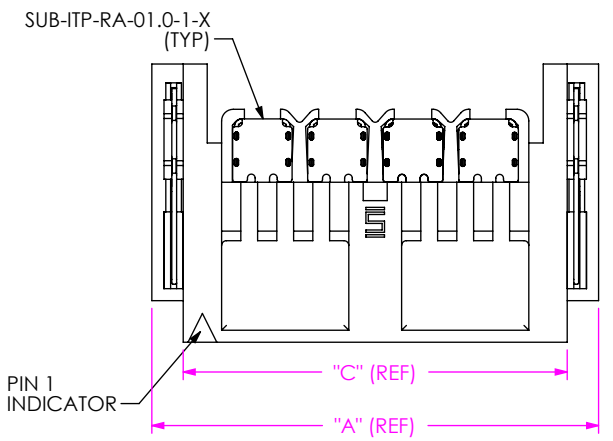

No. OF POSITIONS PER ROW
 -02: 2 POSITIONS
 -04: 4 POSITIONS
 -06: 6 POSITIONS
 -08: 8 POSITIONS

LEAD STYLE
 -01: RIGHT ANGLE

PLATING OPTIONS
 -L: 10μ" GOLD ON CONTACT, MATTE TIN ON SIGNAL TAILS, SHIELDS, & WELD TABS
 -S: 30μ" GOLD ON CONTACT, MATTE TIN ON SIGNAL TAILS, SHIELDS, & WELD TABS

PACKAGING (SEE NOTE 6 & 7)
 -TR: TAPE AND REEL
 -FR: FULL REEL QTY TAPE & REEL

OPTIONS
 -L: CABLE LATCH

TAIL OPTIONS
 -RA1: .062" THICK BOARD

ROW
 -S: SINGLE ROW

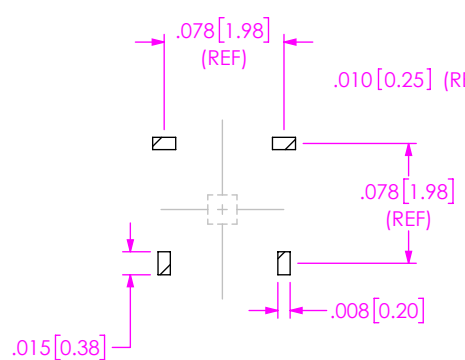
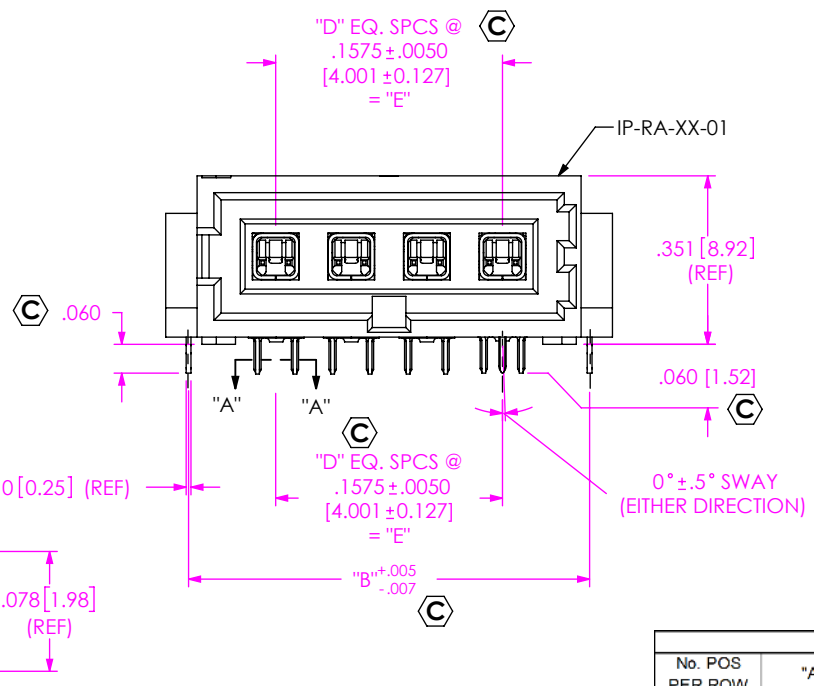
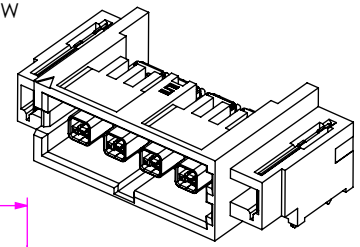

SECTION "A"-"A"
 SCALE 8 : 1

FIG 1
 (IP5-04-01-L-S-XXX-X SHOWN)

TABLE 2

No. POS PER ROW	"A" (REF)	"B"	"C" (REF)	"D"	"E"
-02	0.616 [15.64]	0.523 [13.27]	0.485 [12.32]	1	0.1575 [4.001]
-04	0.931 [23.64]	0.838 [21.27]	0.800 [20.32]	3	0.4725 [12.002]
-06	1.246 [31.64]	1.153 [29.27]	1.115 [28.32]	5	0.7875 [20.003]
-08	1.561 [39.64]	1.468 [37.27]	1.430 [36.32]	7	1.1025 [28.004]

TABLE 1

ASSEMBLY	BODY	SUB-ASSEMBLY	WELD TAB
IP5-XX-01-X-S-RA1	IP-RA-XX-01	SUB-ITP-RA-01.0-1-X	WT-45-01-T
IP5-XX-01-X-S-RA1-L	IP-RA-XX-01-L	SUB-ITP-RA-01.0-1-X	WT-45-01-T

- NOTES:**
1. Ⓢ REPRESENTS A CRITICAL DIMENSION.
 2. DELETED
 3. NOTE DELETED
 4. ITP5-RA AND WT PUSH OUT TO BE .5 LBS (2.2N)
 5. TAPE & REEL IS STANDARD PACKAGING.
 6. ORDERS WILL BE PACKAGED ACCORDING TO THE SAMTEC PACKAGING EFFICIENCY STANDARDS (SPES) FOUND ON WWW.SAMTEC.COM
 7. ATTACH LABEL -4X2 TO EACH REEL

UNLESS OTHERWISE SPECIFIED, DIMENSIONS ARE IN INCHES [MILLIMETERS]

TOLERANCES ARE:
 DECIMALS ANGLES
 .XX: ±.01 [.3] 2°
 .XXX: ±.005 [.13]
 .XXXX: ±.0030 [.076]

PROPRIETARY NOTE
 THIS DOCUMENT CONTAINS CONFIDENTIAL AND PROPRIETARY INFORMATION AND ALL DESIGN, MANUFACTURING, REPRODUCTION, USE, PATENT RIGHTS AND SALES RIGHTS ARE EXPRESSLY RESERVED BY SAMTEC, INC. THIS DOCUMENT SHALL NOT BE DISCLOSED, IN WHOLE OR PART, TO ANY UNAUTHORIZED PERSON OR ENTITY NOR REPRODUCED, TRANSFERRED OR INCORPORATED IN ANY OTHER PROJECT IN ANY MANNER WITHOUT THE EXPRESS WRITTEN CONSENT OF SAMTEC, INC.

MATERIAL: DO NOT SCALE DRAWING SHEET SCALE: 4:1
 BODY: HIGH TEMP NYLON
 SHIELD & WELD TAB: PHOS BRZ.
 TERMINAL: COPPER ALLOY
 DIELECTRIC: LCP, COLOR: BLACK



520 PARK EAST BLVD, NEW ALBANY, IN 47150
 PHONE: 812-944-6733 FAX: 812-948-5047
 e-Mail: info@SAMTEC.com code: 55322

DESCRIPTION:
 IP5-RA CONNECTOR ASSEMBLY

DWG. NO.
IP5-XX-01-X-X-RA1-X-XR

BY: KNOWLDEN 6/27/08 **SHEET 1 OF 2**

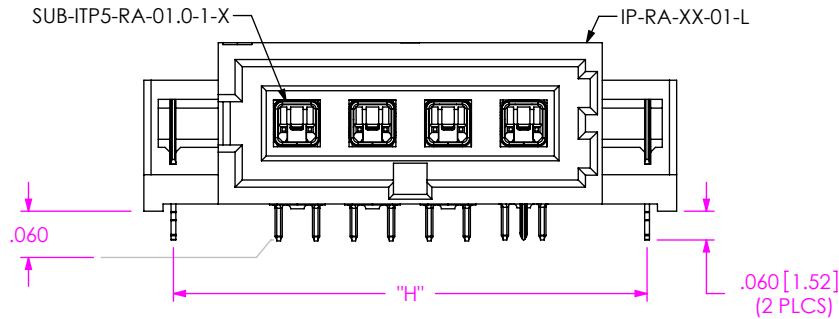
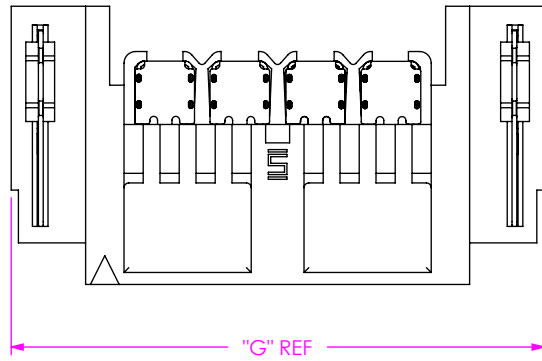
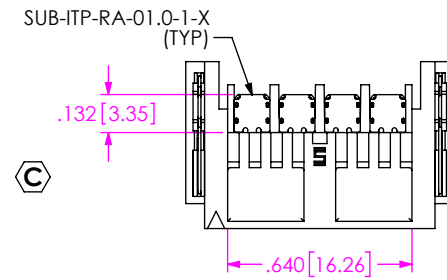

FIG 2
(IP5-04-01-L-S-XXX-L SHOWN)
(SAME AS FIG 1, EXCEPT AS SHOWN)

TABLE 4				
No. POS PER ROW	"G" (REF)		"H"	
	-02	0.795	[20.19]	0.672
-04	1.110	[28.19]	0.987	[25.06]
-06	1.425	[36.20]	1.302	[33.06]
-08	1.740	[44.20]	1.617	[41.06]

PROCESS STEP 1
(FILLING ITP-RA SUB ASSEMBLIES INTO BODY)



PROCESS STEP 2
(HEAT STAKING ITP-RA SUB ASSEMBLIES INTO BODY)

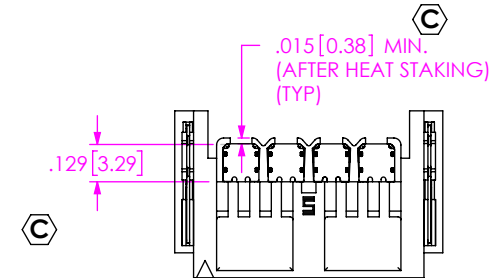

PROCESS STEP 3
(FILL WT-45-XX-T WELD TABS)

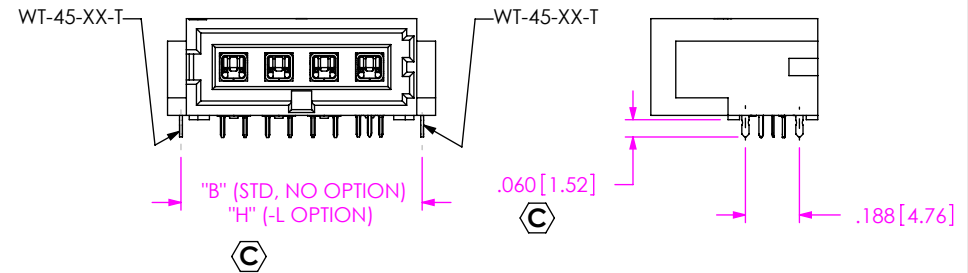

PROPRIETARY NOTE
THIS DOCUMENT CONTAINS CONFIDENTIAL AND PROPRIETARY INFORMATION AND ALL DESIGN, MANUFACTURING, REPRODUCTION, USE, PATENT RIGHTS AND SALES RIGHTS ARE EXPRESSLY RESERVED BY SAMTEC, INC. THIS DOCUMENT SHALL NOT BE DISCLOSED, IN WHOLE OR PART, TO ANY UNAUTHORIZED PERSON OR ENTITY NOR REPRODUCED, TRANSFERRED OR INCORPORATED IN ANY OTHER PROJECT IN ANY MANNER WITHOUT THE EXPRESS WRITTEN CONSENT OF SAMTEC, INC.

DO NOT SCALE DRAWING

SHEET SCALE: 4:1

samtec

520 PARK EAST BLVD, NEW ALBANY, IN 47150
PHONE: 812-944-6733 FAX: 812-948-5047
e-Mail: info@SAMTEC.com code: 55322

DESCRIPTION:
IP5-RA CONNECTOR ASSEMBLY

DWG. NO.
IP5-XX-01-X-X-RA1-X-XR

BY: KNOWLDEN 6/27/08 SHEET 2 OF 2