

# CCFL Transformers

## Cold cathode fluorescent lamp inverter transformers

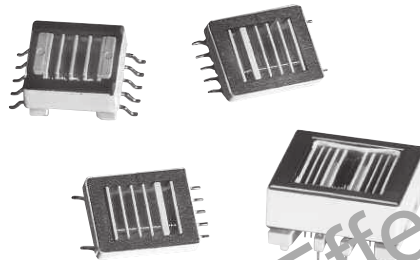

### Applications

- CCFL power supplies

### Environmental data

- Storage temperature range: -40°C to +85°C
- Operating ambient temperature range: 0°C to +70°C

### Packaging

- Supplied in bulk packaging

### Product description

- Transformers for use in CCFL power supplies, available in through-hole and surface mount recess or gull wing versions, incorporating floating or fixed secondary technology
- Supply output current up to 30 milli-Amps
- Frequency range from 40 to 80 KHz
- Deliver output power from 2.5 to 14 Watts
- Operate in royer and other topologies
- Ferrite core material



Discontinued, Effective August 31, 2017 or until inventory is depleted. No recommended replacement available

Product specifications

Part number	Schematic diagram	Pout watts	Lp uH <sup>1</sup>	DCRp ohms max	DCRs ohms max	TR Ns/Np	Vpri volts max <sup>2</sup>	Vsec volts max <sup>2</sup>	Is max A rms	Vpri abnormal <sup>3</sup>	Vsec abnormal <sup>3</sup>	Mechanical dimensions	PCB pad layout
<b>2.5 Watt Versions</b>													
CTX110652-R	A	2.5	43	0.220	285	67	20	1340	.005	30	2000	A	A
CTX110655-R	B	2.5	43	0.220	285	67	20	1340	.005	30	2000	A	A
CTX110657-R	B	2.5	26	0.190	285	86	15	1340	.005	23	2000	A	A
CTX110659-R	B	2.5	19	0.220	285	100	13	1340	.005	23	2000	A	A
CTX210652-R	A	2.5	43	0.220	285	67	20	1340	.005	30	2000	B	B
CTX210655-R	B	2.5	43	0.220	285	67	20	1340	.005	30	2000	B	B
CTX210657-R	B	2.5	26	0.212	285	86	15	1340	.005	23	2000	B	B
CTX210659-R	B	2.5	19	0.190	285	100	13	1340	.005	23	2000	B	B
<b>2.5 Watt Versions</b>													
CTX210403-R	C	4	44	0.220	165	50	26	1340	.007	40	2000	C	C
CTX210407-R	C	4	27	0.160	220	86	15	1340	.007	23	2000	C	C
CTX210409-R	C	4	20	0.160	220	100	13	1340	.007	23	2000	C	C
CTX210411-R	C	4	20	0.160	330	125	11	1340	.007	16	2000	C	C
CTX310403-R	C	4	44	0.220	165	50	26	1340	.007	40	2000	D	D
CTX310407-R	C	4	27	0.160	220	86	15	1340	.007	23	2000	D	D
CTX310409-R	C	4	20	0.160	220	100	13	1340	.007	23	2000	D	D
CTX310411-R	C	4	20	0.160	330	125	11	1340	.007	16	2000	D	D
<b>6 Watt Versions</b>													
CTX110600-R	D	6	44	0.160	176	67	20	1340	.011	30	2000	E	E
CTX110603-R	C	6	44	0.160	132	50	26	1340	.011	40	2000	E	E
CTX110605-R	C	6	44	0.160	176	67	20	1340	.011	30	2000	E	E
CTX110607-R	C	6	27	0.132	176	86	15	1340	.011	23	2000	E	E
CTX110609-R	C	6	20	0.132	176	100	13	1340	.011	23	2000	E	E
CTX110611-R	C	6	20	0.132	291	125	11	1340	.011	16	2000	E	E
CTX210600-R	D	6	44	0.160	176	67	20	1340	.011	30	2000	F	C
CTX210603-R	C	6	44	0.160	132	50	26	1340	.011	40	2000	F	C
CTX210605-R	C	6	44	0.160	176	67	20	1340	.011	30	2000	F	C
CTX210607-R	C	6	27	0.132	176	86	15	1340	.011	23	2000	F	C
CTX210609-R	C	6	20	0.132	176	100	13	1340	.011	23	2000	F	C
CTX210611-R	C	6	20	0.132	291	125	11	1340	.011	16	2000	F	C
<b>14 Watt Versions</b>													
CTX410805-R	E	14	24	0.030	262	67	20	1340	.030	30	2000	G	F
CTX410807-R	E	14	16	0.024	272	86	15	1340	.030	23	2000	G	F
CTX410809-R	E	14	16	0.024	314	100	13	1340	.030	23	2000	G	F

1. Inductances are nominal values  
2. Continuous RMS Voltage  
3. Maximum Instantaneous RMS Voltage

Dimensions—mm

2.5 Watt Versions

Mechanical A

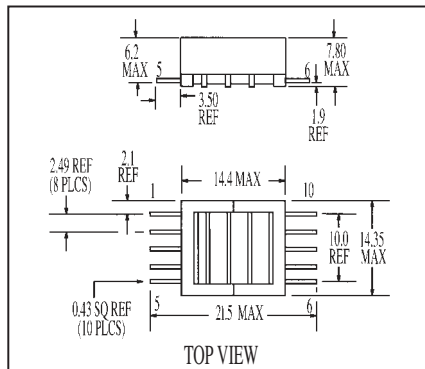

Mechanical B

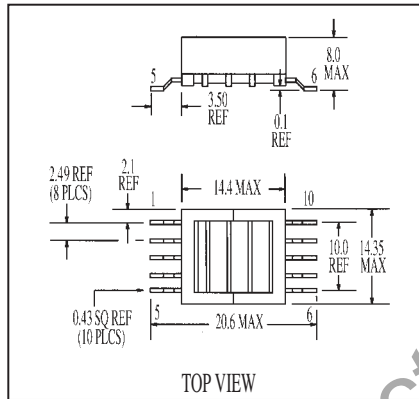

Pad Layout A

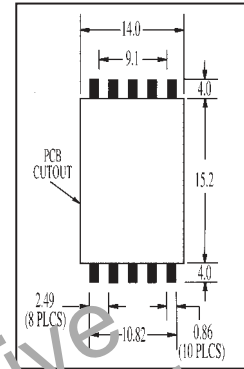

Pad Layout B

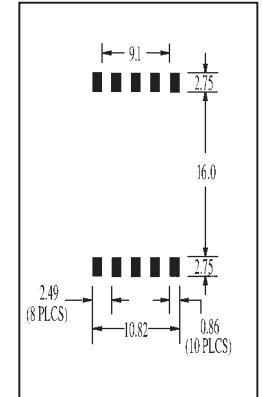

Schematic A

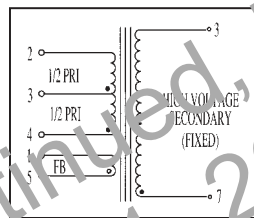

Schematic B

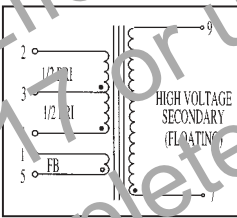

4 Watt Versions

Mechanical C

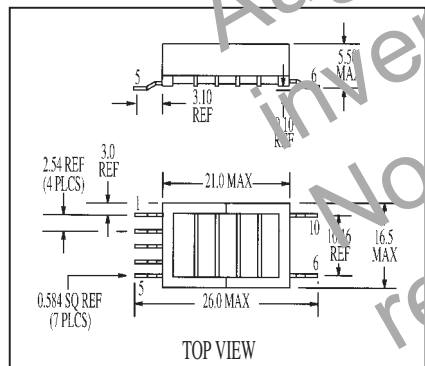

Mechanical D

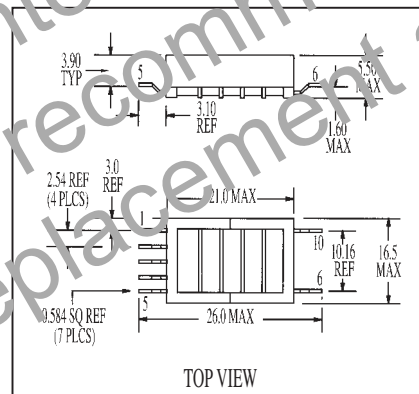

Pad Layout C

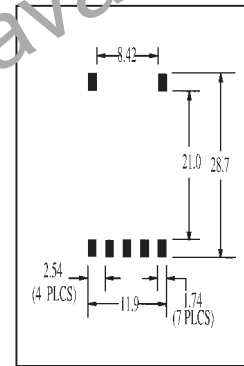

Pad Layout D

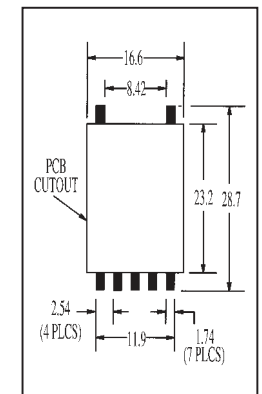

Schematic C

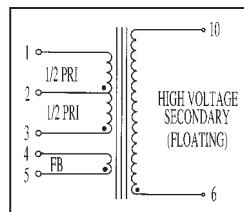

Discontinued, Effective August 31, 2017 or until inventory is depleted. No replacement available.

Dimensions—mm

6 Watt Versions

Mechanical E

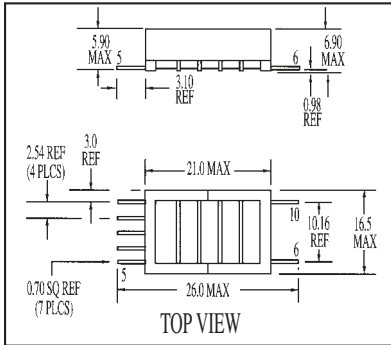

Mechanical F

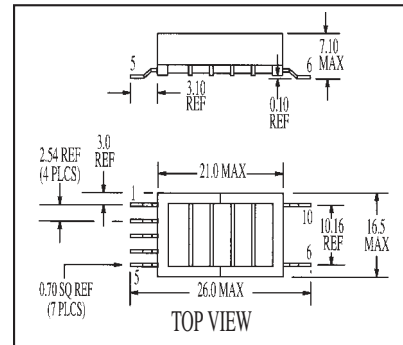

Pad Layout E

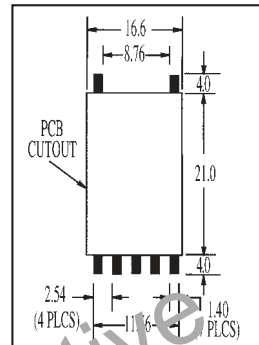

Pad Layout C

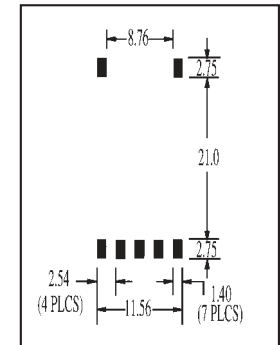

Schematic D

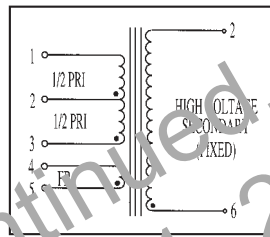

Schematic C

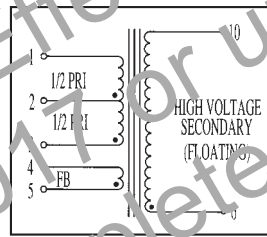

14 Watt Versions

Schematic E

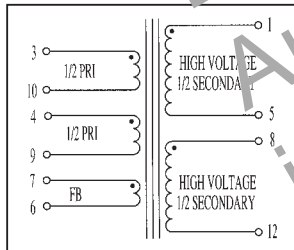

Pad Layout F

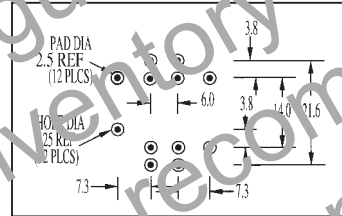

Mechanical C

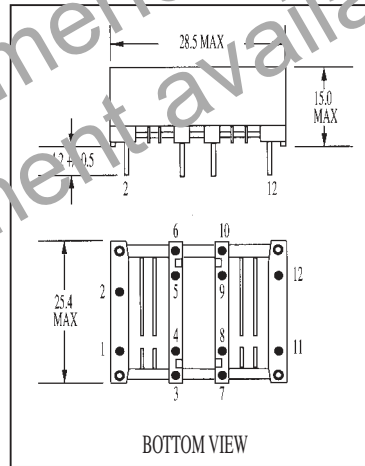

**Through-hole wave solder profile**

Reflow soldering not recommended

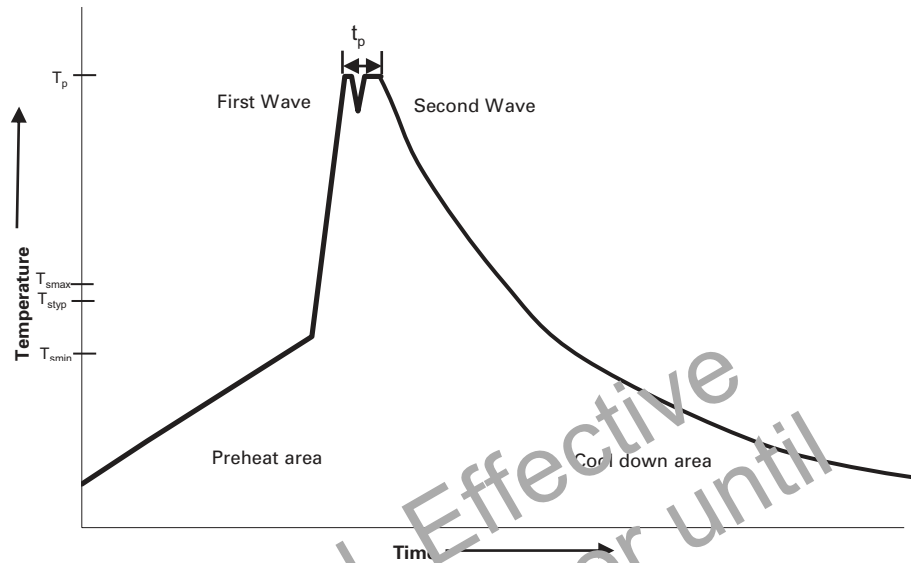

**Reference EN 61760-1:2006**

Profile Feature	Standard Sn/Pb Solder	Lead (Pb) Free Solder
Preheat		
• Temperature min. (T <sub>smin</sub> )	100°C	100°C
• Temperature typ. (T <sub>styp</sub> )	120°C	120°C
• Temperature max. (T <sub>smax</sub> )	150°C	130°C
• Time (T <sub>smin</sub> to T <sub>smax</sub> ) (t <sub>s</sub> )	70 seconds	70 seconds
Δ preheat to max Temperature	150°C max.	150°C max.
Peak temperature (T <sub>p</sub> )*	235°C – 260°C	250°C – 260°C
Time at peak temperature (t <sub>p</sub> )	10 seconds max 5 seconds max each wave	10 seconds max 5 seconds max each wave
Ramp-down rate	~ 2 K/s min 2.5 K/s typ ~ 5 K/s max	~ 2 K/s min ~ 3.5 K/s typ ~ 5 K/s max
Time 25°C to 25°C	4 minutes	4 minutes

**Manual solder**

350°C, 4-5 seconds. (by soldering iron), generally manual, hand soldering is not recommended.

**Surface mount solder reflow profile**

Wave and manual soldering not recommended

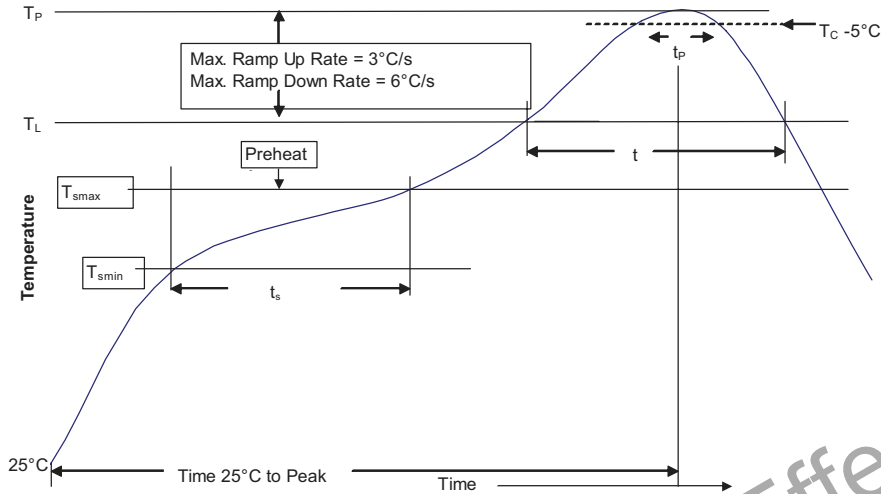

**Table 1 - Standard SnPb Solder (T<sub>c</sub>)**

Package Thickness	Volume mm <sup>3</sup> <350	Volume mm <sup>3</sup> ≥350
<2.5mm)	235°C	220°C
≥2.5mm	220°C	220°C

**Table 2 - Lead (Pb) Free Solder (T<sub>c</sub>)**

Package Thickness	Volume mm <sup>3</sup> <350	Volume mm <sup>3</sup> 350 - 2000	Volume mm <sup>3</sup> >2000
<1.6mm	260°C	260°C	260°C
1.6 - 2.5mm	260°C	250°C	245°C
>2.5mm	250°C	245°C	245°C

**Reference JDEC J-STD-020D**

Profile Feature	Standard SnPb Solder	Lead (Pb) Free Solder
Preheat and Soak		
• Temperature min. (T <sub>smin</sub> )	100°C	150°C
• Temperature max. (T <sub>smax</sub> )	150°C	200°C
• Time (T <sub>smin</sub> to T <sub>smax</sub> ) (t <sub>s</sub> )	60-120 Seconds	60-120 Seconds
Average ramp up rate (T <sub>smax</sub> to T <sub>p</sub> )	3°C/ Second Max.	3°C/ Second Max.
Liquidous temperature (T <sub>L</sub> )	183°C	217°C
Time at liquidous (t <sub>L</sub> )	60-150 Seconds	60-150 Seconds
Peak package body temperature (T <sub>p</sub> )*	Table 1	Table 2
Time (t <sub>p</sub> )** within 5 °C of the specified classification temperature (T <sub>c</sub> )	30 Seconds**	30 Seconds**
Average ramp-down rate (T <sub>p</sub> to T <sub>smax</sub> )	6°C/ Second Max.	6°C/ Second Max.
Time 25°C to Peak Temperature	6 Minutes Max.	8 Minutes Max.

\* Tolerance for peak profile temperature (T<sub>p</sub>) is defined as a supplier minimum and a user maximum.

\*\* Tolerance for time at peak profile temperature (t<sub>p</sub>) is defined as a supplier minimum and a user maximum.

Life Support Policy: Eaton does not authorize the use of any of its products for use in life support devices or systems without the express written approval of an officer of the Company. Life support systems are devices which support or sustain life, and whose failure to perform, when properly used in accordance with instructions for use provided in the labeling, can be reasonably expected to result in significant injury to the user.

Eaton reserves the right, without notice, to change design or construction of any products and to discontinue or limit distribution of any products. Eaton also reserves the right to change or update, without notice, any technical information contained in this bulletin.

**Eaton**  
Electronics Division  
1000 Eaton Boulevard  
Cleveland, OH 44122  
United States  
www.eaton.com/elx

© 2015 Eaton  
All Rights Reserved  
Printed in USA  
Publication No. PM-4303  
October 2015



Eaton is a registered trademark.

All other trademarks are property of their respective owners.