

THIS DRAWING IS UNPUBLISHED. RELEASED FOR PUBLICATION  
 © COPYRIGHT BY TYCO ELECTRONICS CORPORATION. ALL RIGHTS RESERVED.

LOC	DIST	REVISIONS			
P	LTR	DESCRIPTION	DATE	DWN	APVD
AA	00	B	ECO-07-017784	14AUG07	LAM PR

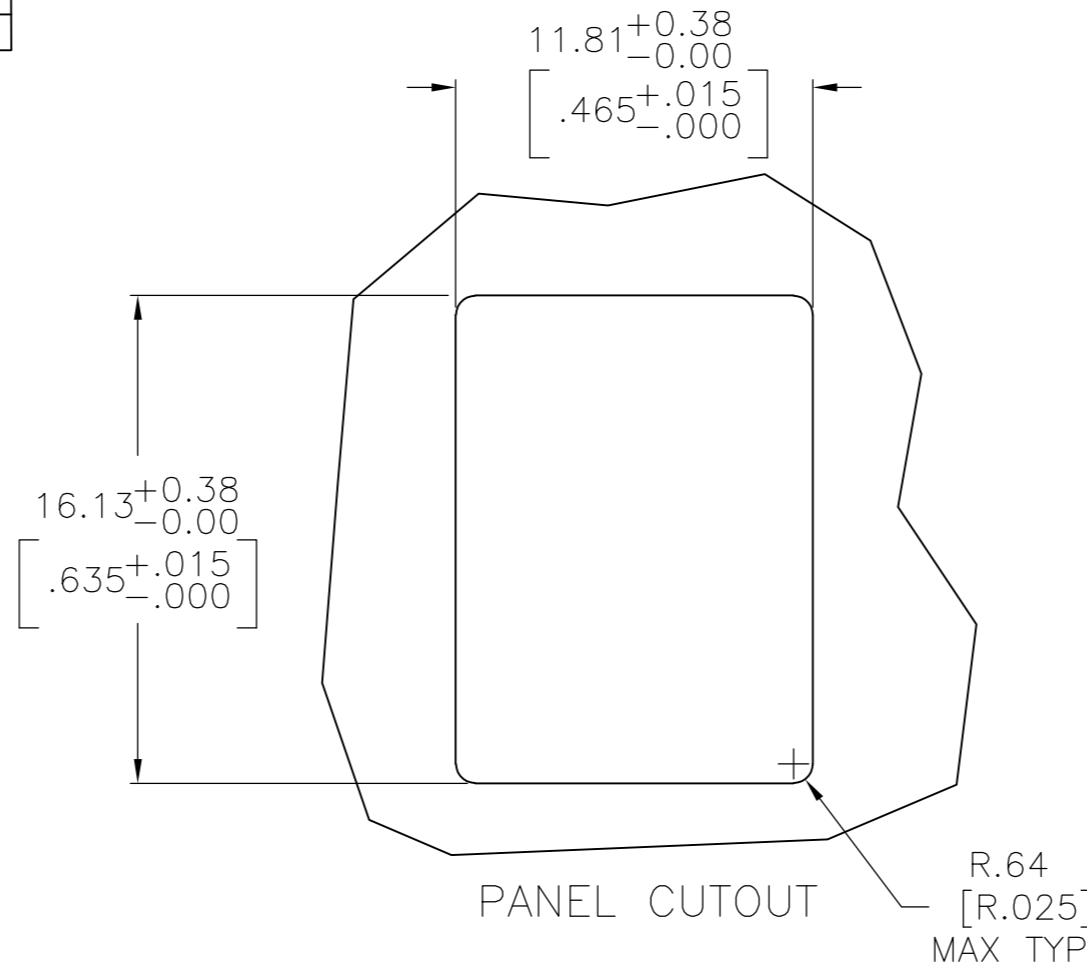

- MATERIAL: HOUSING - HTN MOLDING COMPOUND, UL 94V-0, COLOR: BLACK  
 TERMINAL - 0.36[.014] THICK PHOS BRONZE PLATED WITH 1.27μm [.000050] MIN THICK HARD GOLD IN LOCALIZED GOLD PLATE AREA, 3.81μm [.000150] MIN THICK MATTE TIN IN SOLDER AREA AND 1.27μm [.000050] MIN THICK NICKEL UNDERPLATE
- CAVITY CONFORMS TO FCC RULES AND REGULATIONS PART 68 AND REA BULLETIN 345-81 PE-76 SPECIFICATION FOR MODULAR TELEPHONE HARDWARE.
- BULK PACKAGED IN A TRAY.

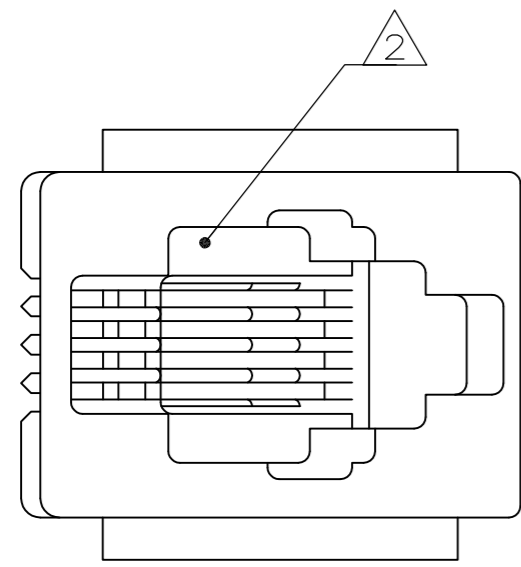
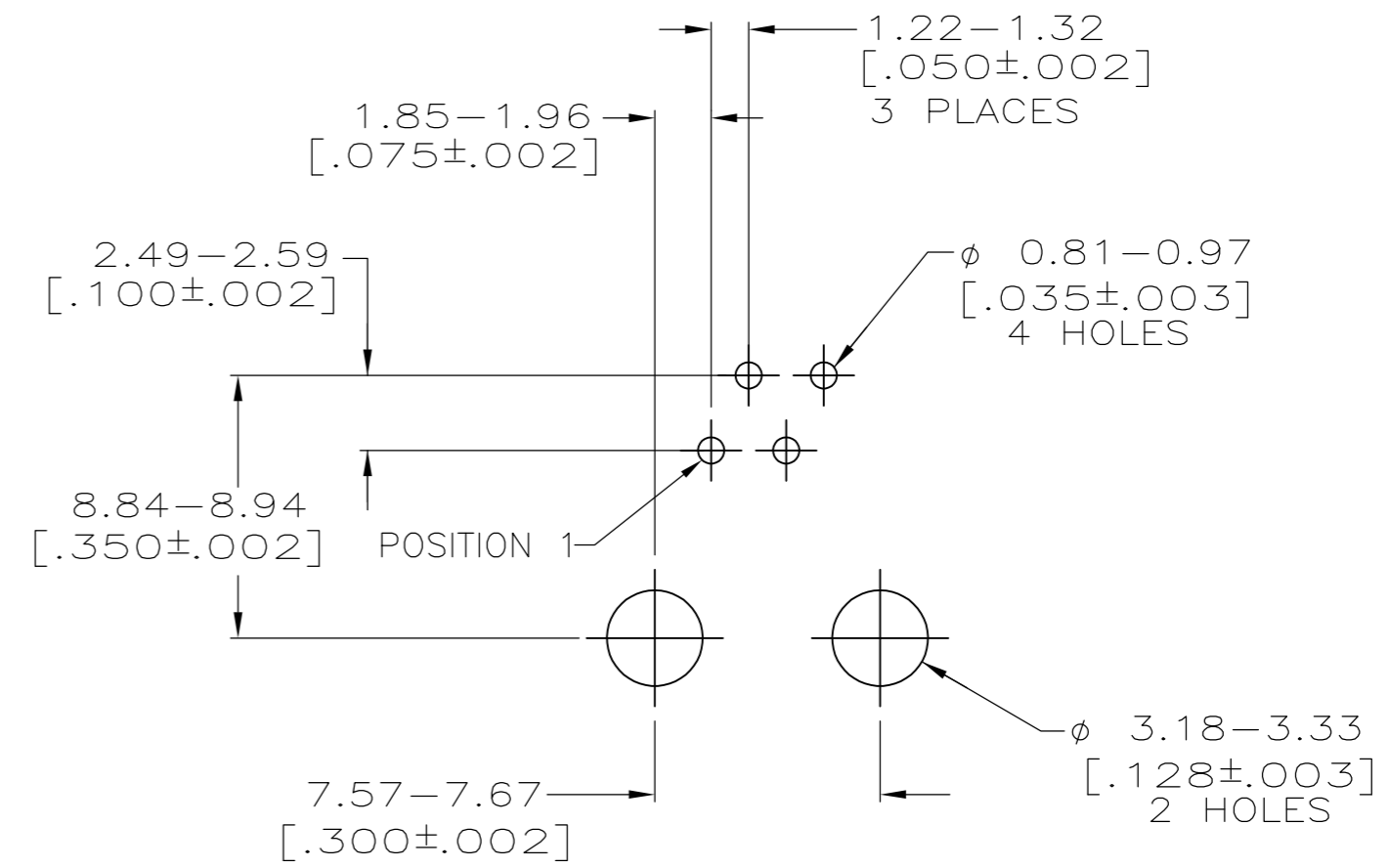
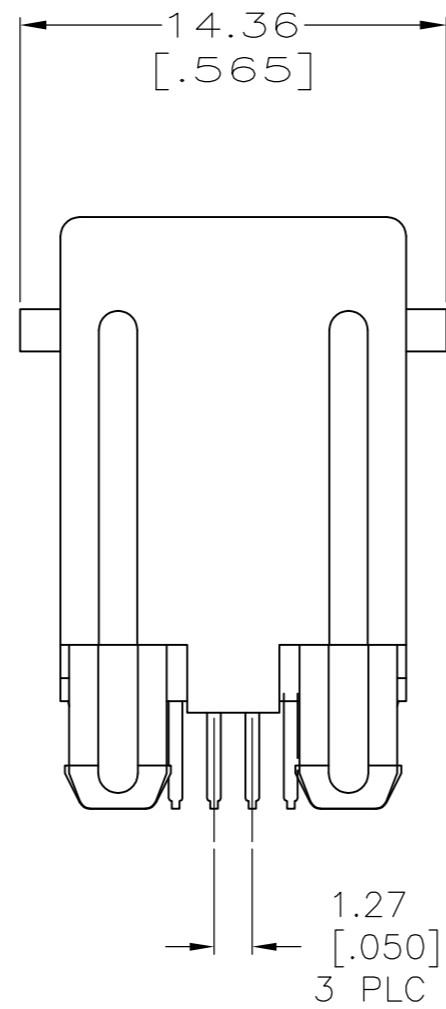
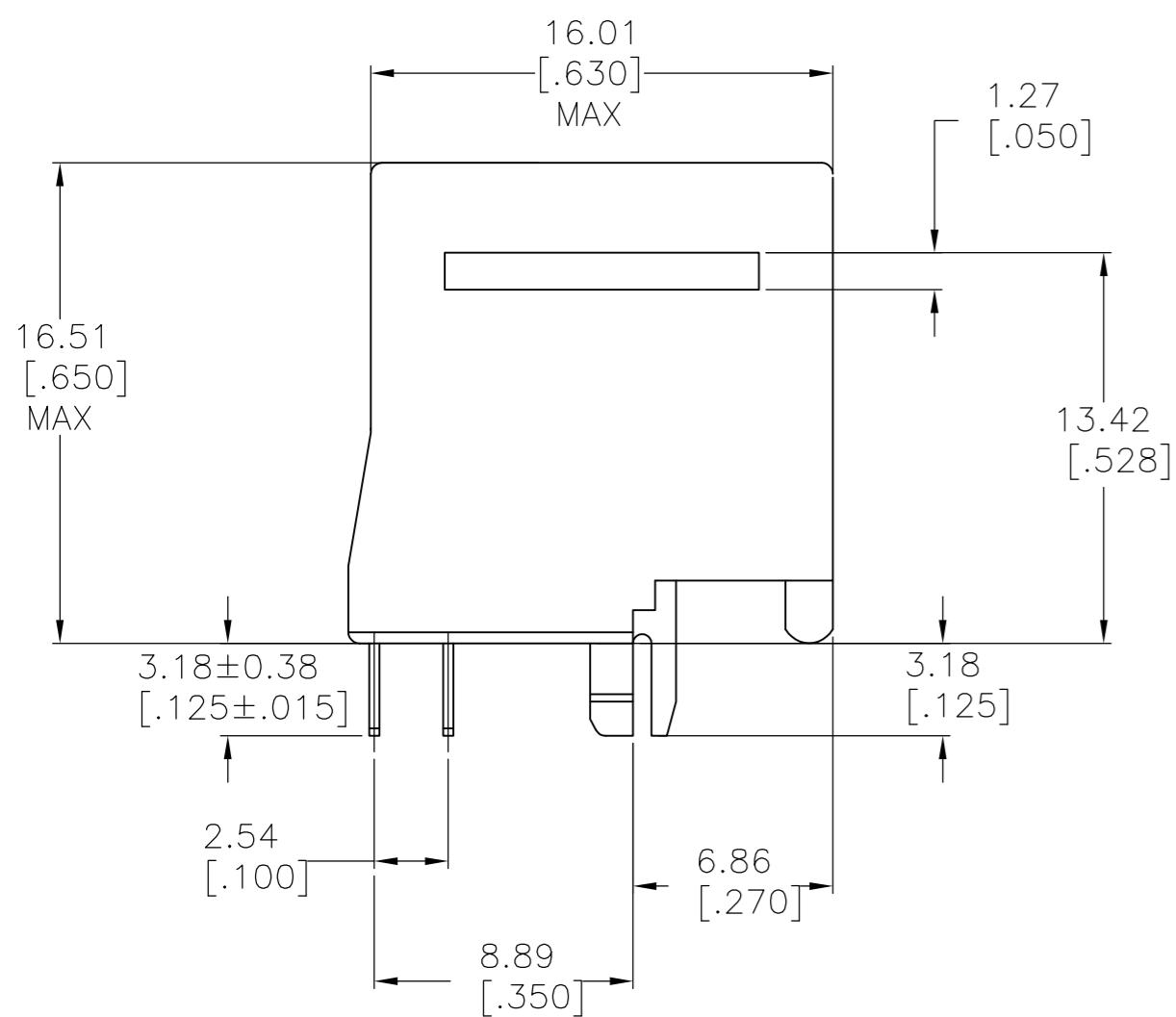

SUGGESTED PRINTED CIRCUIT BOARD LAYOUT  
 COMPONENT SIDE

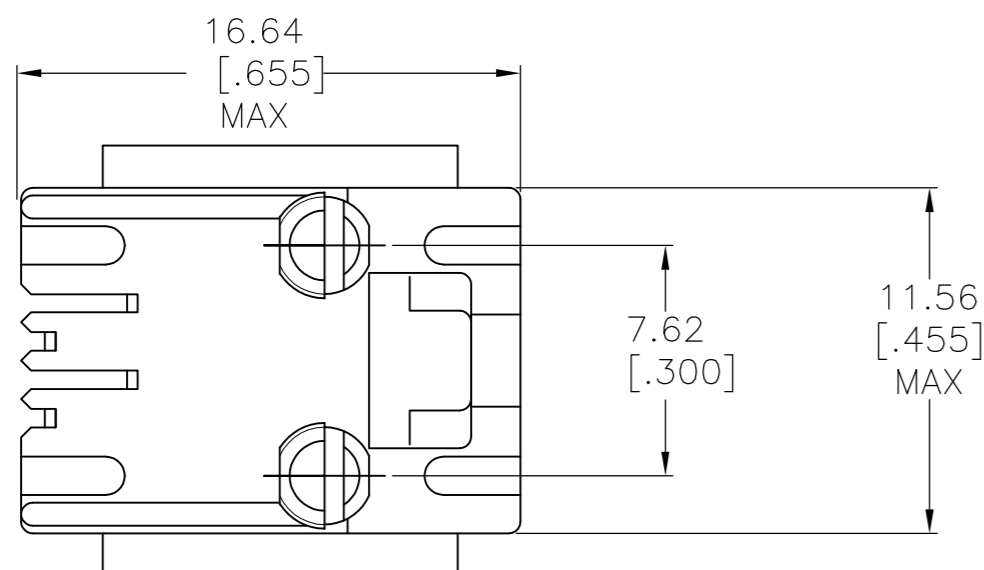

5569282-1  
 PART NO.

THIS DRAWING IS A CONTROLLED DOCUMENT.		DWN L.A.MAYER 14AUG2007	Tyco Electronics Corporation Harrisburg, Pa 17105-3608	
DIMENSIONS: mm [INCHES]		CHK P.RECCE 14AUG2007	NAME MOD JACK ASSEMBLY, TOP ENTRY, 4 POSITION WITH PANEL STOPS	
TOLERANCES UNLESS OTHERWISE SPECIFIED:		APVD S.FLICKINGER 14AUG2007	PRODUCT SPEC 108-1163	
0 PLC ± -		APPLICATION SPEC 114-2048		SIZE A2
1 PLC ± -		WEIGHT -		CAGE CODE 00779
2 PLC ± 0.13[.005]		CUSTOMER DRAWING		DRAWING NO C=5569282
3 PLC ± -		SCALE 4:1		SHEET 1 OF 1
4 PLC ± -		REV B		RESTRICTED TO -
ANGLES ± -				
FINISH SEE NOTE 1				