

Unplugged Schematic

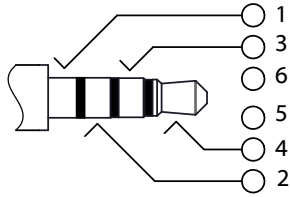

Plugged Schematic

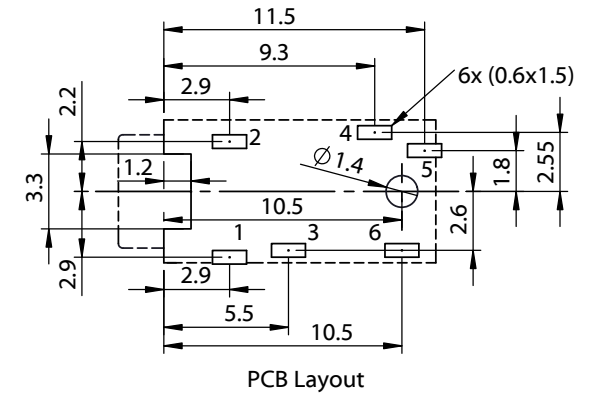
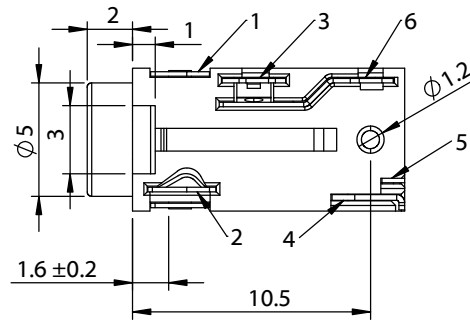
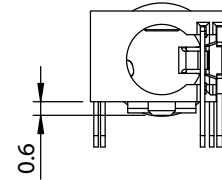
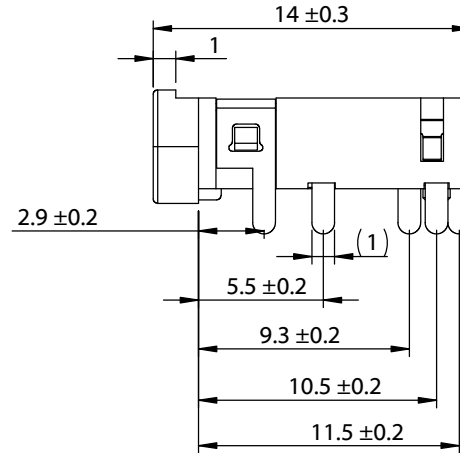
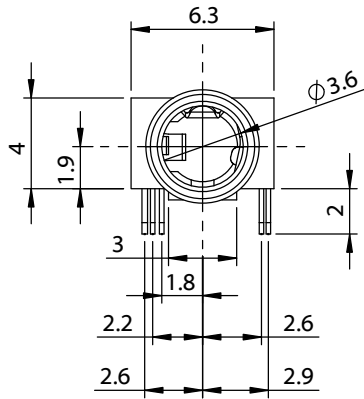
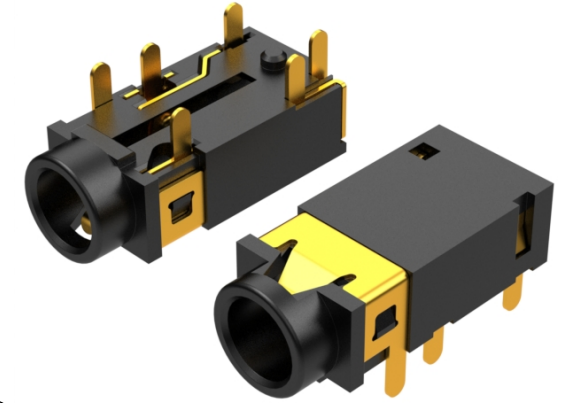

PCB Layout

Revision:	Date:	Description:	Prepared:	Notes:	<h1>TENSILITY</h1>
A	1/11/22	Initial release	JD <small>Digitally signed by JD Date: 2022.01.12 13:43:54 -08'00'</small>	RoHS compliant	
			Verified:	Function test: no open, no short circuit, no intermittent	tel 1.541.323.3228 800 877.670.7118 fax 1.541.323.4202 web tensility.com
			Dimensions are in millimeters. Tolerances: X: ± 0.5 mm X.X: ± 0.3 mm X.XX: ± 0.05 mm	Description: Connector, 4C audio jack, 3.5xL14 mm, thru hole, gold plated	Size: A Part number: 54-00298
					Scale: 1:1 Sheet 1 of 2

5

4

3

2

1

Ratings

Voltage: 48 V
Current: 0.5 A

Operating Temperature Range

-40 ~ 105 °C, relative humidity of 85% or less

Materials

- ① #1 contact: phosphor bronze, gold plating
- ② #2 contact: phosphor bronze, gold plating
- ③ #3 contact: phosphor bronze, gold plating
- ④ #4 contact: phosphor bronze, gold plating
- ⑤ #5 contact: phosphor bronze, gold plating
- ⑥ #6 contact: phosphor bronze, gold plating
- ⑦ Housing: PA9T, black, UL 94 V-0

Electrical Requirements

Dielectric strength: 1 min @ 500 Vac
Insulation resistance: 100 MΩ @ 250 Vdc
Contact resistance: 30 mΩ or less at 1 KHz

Mechanical Requirements

Insertion force: 0.3-2 kgf
Withdrawal force: 0.3-2 kgf
Life cycle: 5000 mating cycles while maintaining 0.3 kgf min. insertion force, 0.2 kgf min. withdrawal force and less than 100 mΩ contact resistance
Terminal strength: 500 gf applied in one direction to the tip of the terminal for 1 second without mechanical or electrical damage

Soldering

Solderability: 90% minimum coverage when terminals dipped 2mm in 260 ±5 °C solder bath for 3 ±0.5 seconds
Solder bath durability: no deformation when immersed in 255 ±5 °C up to surface of the board 1.6 mm for 5 seconds or less
Solder iron durability: no deformation when exposed to 350 ±10 °C for 5 seconds or less

Environmental Requirements

Cold test: -40 ±2 °C for 48 hours without deformation
Heat test: 70 °C, relative humidity 70-85% for 96 hours without deformation
Humidity test: 40 ±2 °C, relative humidity 90-100% for 96 hours without deformation
Salt spray test: 35 ±2 °C, 5% NaCl mist for 24 hrs. Wash parts after test. No remarkable corrosion shall be present

Packaging

1000 pieces/ reel
12 reels/ box

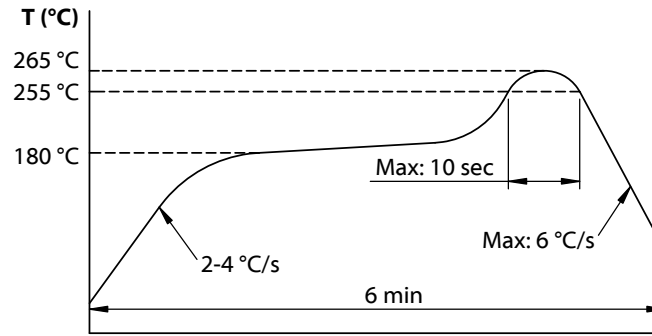

Reflow soldering temperature profile

Packaging Detail

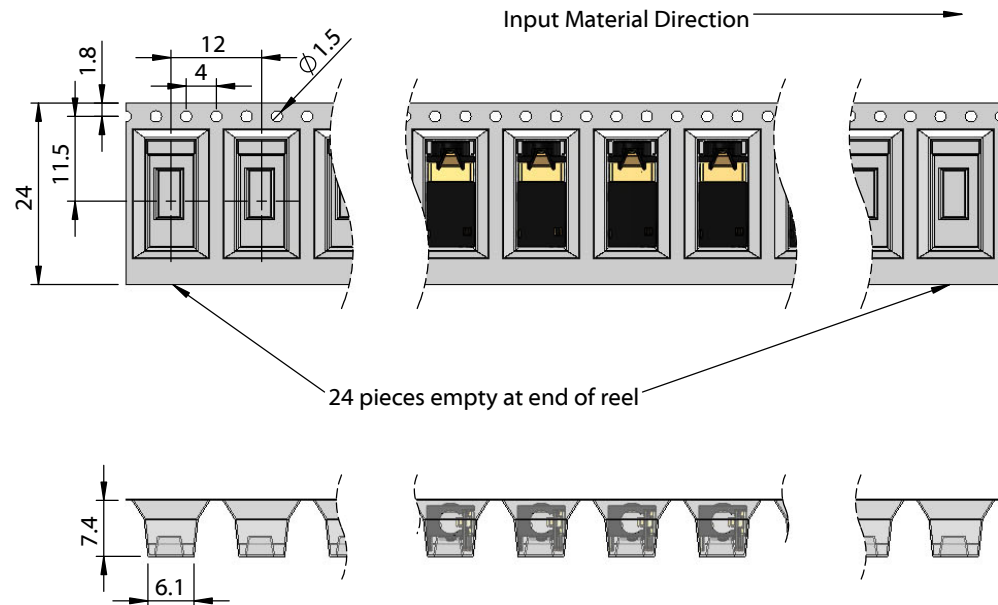

Revision:	Date:	Description:	Prepared:	Notes:	TENSILITY tel 1.541.323.3228 800 877.670.7118 fax 1.541.323.4202 web tensility.com
A	1/11/22	Initial release	JD <small>Digitally signed by JD Date: 2022.01.12 13:44:05 -08'00'</small>	RoHS compliant	
			Verified:	Function test: no open, no short circuit, no intermittent	Size: Part number:
			AG <small>Digitally signed by AG Date: 2022.01.19 11:47:27 -08'00'</small>	Description:	A 54-00298
			Dimensions are in millimeters. Tolerances: X: ± 0.3 mm X.X: ± 0.1 mm X.XX: ± 0.05 mm	Connector, 4C audio jack, 3.5xL14 mm, thru hole, gold plated	Scale: 5:1
					Sheet 2 of 2

5

4

3

2

1