

National Semiconductor is now part of
Texas Instruments.

Search <http://www.ti.com/> for the latest technical
information and details on our current products and services.

LM148/LM248/LM348

Quad 741 Op Amps

General Description

The LM148 series is a true quad 741. It consists of four independent, high gain, internally compensated, low power operational amplifiers which have been designed to provide functional characteristics identical to those of the familiar 741 operational amplifier. In addition the total supply current for all four amplifiers is comparable to the supply current of a single 741 type op amp. Other features include input offset currents and input bias current which are much less than those of a standard 741. Also, excellent isolation between amplifiers has been achieved by independently biasing each amplifier and using layout techniques which minimize thermal coupling.

The LM148 can be used anywhere multiple 741 or 1558 type amplifiers are being used and in applications where amplifier matching or high packing density is required. For lower power refer to LF444.

Features

- 741 op amp operating characteristics
- Class AB output stage—no crossover distortion
- Pin compatible with the LM124
- Overload protection for inputs and outputs
- Low supply current drain: 0.6 mA/Amplifier
- Low input offset voltage: 1 mV
- Low input offset current: 4 nA
- Low input bias current: 30 nA
- Low input bias current: 30 nA
- High degree of isolation between amplifiers: 120 dB
- Gain bandwidth product
- LM148 (unity gain): 1.0 MHz

Schematic Diagram

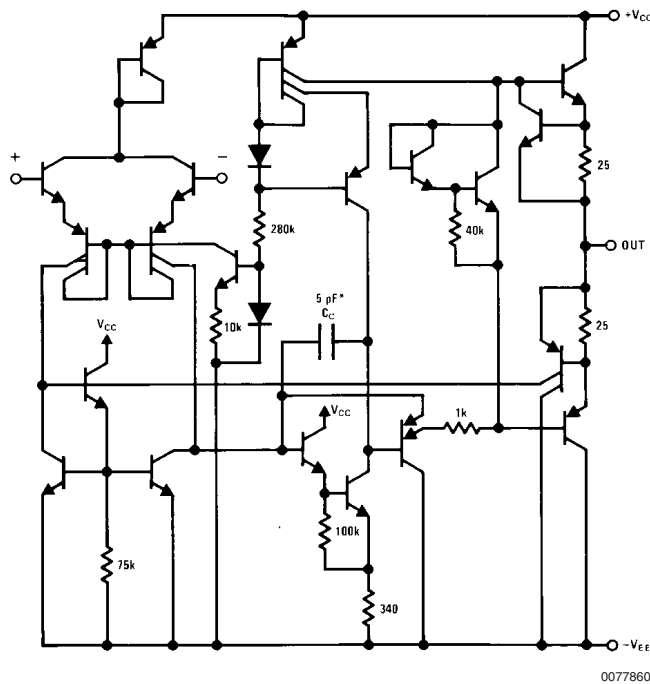

* 1 pF in the LM149

Absolute Maximum Ratings (Note 4)

Distributors for availability and specifications.

If Military/Aerospace specified devices are required,
please contact the National Semiconductor Sales Office/

	LM148	LM248	LM348
Supply Voltage	±22V	±18V	±18V
Differential Input Voltage	±44V	±36V	±36V
Output Short Circuit Duration (Note 1)	Continuous	Continuous	Continuous
Power Dissipation (P_d at 25°C) and Thermal Resistance (θ_{JA}), (Note 2)			
Molded DIP (N) P_d	—	—	750 mW
θ_{JA}	—	—	100°C/W
Cavity DIP (J) P_d	1100 mW	800 mW	700 mW
θ_{JA}	110°C/W	110°C/W	110°C/W
Maximum Junction Temperature (T_{JMAX})	150°C	110°C	100°C
Operating Temperature Range	-55°C ≤ T_A ≤ +125°C	-25°C ≤ T_A ≤ +85°C	0°C ≤ T_A ≤ +70°C
Storage Temperature Range	-65°C to +150°C	-65°C to +150°C	-65°C to +150°C
Lead Temperature (Soldering, 10 sec.) Ceramic	300°C	300°C	300°C
Lead Temperature (Soldering, 10 sec.) Plastic			260°C
Soldering Information			
Dual-In-Line Package			
Soldering (10 seconds)	260°C	260°C	260°C
Small Outline Package			
Vapor Phase (60 seconds)	215°C	215°C	215°C
Infrared (15 seconds)	220°C	220°C	220°C
See AN-450 "Surface Mounting Methods and Their Effect on Product Reliability" for other methods of soldering surface mount devices.			
ESD tolerance (Note 5)	500V	500V	500V

Electrical Characteristics

(Note 3)

Parameter	Conditions	LM148			LM248			LM348			Units
		Min	Typ	Max	Min	Typ	Max	Min	Typ	Max	
Input Offset Voltage	$T_A = 25^\circ\text{C}$, $R_S \leq 10\text{ k}\Omega$		1.0	5.0		1.0	6.0		1.0	6.0	mV
Input Offset Current	$T_A = 25^\circ\text{C}$		4	25		4	50		4	50	nA
Input Bias Current	$T_A = 25^\circ\text{C}$		30	100		30	200		30	200	nA
Input Resistance	$T_A = 25^\circ\text{C}$	0.8	2.5		0.8	2.5		0.8	2.5		MΩ
Supply Current All Amplifiers	$T_A = 25^\circ\text{C}$, $V_S = \pm 15\text{V}$		2.4	3.6		2.4	4.5		2.4	4.5	mA
Large Signal Voltage Gain	$T_A = 25^\circ\text{C}$, $V_S = \pm 15\text{V}$ $V_{OUT} = \pm 10\text{V}$, $R_L \geq 2\text{ k}\Omega$	50	160		25	160		25	160		V/mV
Amplifier to Amplifier Coupling	$T_A = 25^\circ\text{C}$, $f = 1\text{ Hz to } 20\text{ kHz}$ (Input Referred) See Crosstalk Test Circuit		-120			-120			-120		dB
Small Signal Bandwidth	$T_A = 25^\circ\text{C}$, LM148 Series		1.0			1.0			1.0		MHz
Phase Margin	$T_A = 25^\circ\text{C}$, LM148 Series ($A_V = 1$)		60			60			60		degrees
Slew Rate	$T_A = 25^\circ\text{C}$, LM148 Series ($A_V = 1$)		0.5			0.5			0.5		V/μs
Output Short Circuit Current	$T_A = 25^\circ\text{C}$		25			25			25		mA
Input Offset Voltage	$R_S \leq 10\text{ k}\Omega$			6.0			7.5			7.5	mV
Input Offset Current				75			125			100	nA

Electrical Characteristics (Continued)

(Note 3)

Parameter	Conditions	LM148			LM248			LM348			Units
		Min	Typ	Max	Min	Typ	Max	Min	Typ	Max	
Input Bias Current				325			500			400	nA
Large Signal Voltage Gain	$V_S = \pm 15V$, $V_{OUT} = \pm 10V$, $R_L > 2\text{ k}\Omega$	25			15			15			V/mV
Output Voltage Swing	$V_S = \pm 15V$, $R_L = 10\text{ k}\Omega$ $R_L = 2\text{ k}\Omega$	± 12	± 13		± 12	± 13		± 12	± 13		V
		± 10	± 12		± 10	± 12		± 10	± 12		V
Input Voltage Range	$V_S = \pm 15V$	± 12			± 12			± 12			V
Common-Mode Rejection Ratio	$R_S \leq 10\text{ k}\Omega$	70	90		70	90		70	90		dB
Supply Voltage Rejection	$R_S \leq 10\text{ k}\Omega$, $\pm 5V \leq V_S \leq \pm 15V$	77	96		77	96		77	96		dB

Note 1: Any of the amplifier outputs can be shorted to ground indefinitely; however, more than one should not be simultaneously shorted as the maximum junction temperature will be exceeded.

Note 2: The maximum power dissipation for these devices must be derated at elevated temperatures and is dictated by T_{JMAX} , θ_{JA} , and the ambient temperature, T_A . The maximum available power dissipation at any temperature is $P_d = (T_{JMAX} - T_A)/\theta_{JA}$ or the $25^\circ\text{C } P_{DMAX}$, whichever is less.

Note 3: These specifications apply for $V_S = \pm 15V$ and over the absolute maximum operating temperature range ($T_L \leq T_A \leq T_H$) unless otherwise noted.

Note 4: Refer to RETS 148X for LM148 military specifications.

Note 5: Human body model, 1.5 k Ω in series with 100 pF.

Cross Talk Test Circuit $V_S = \pm 15V$

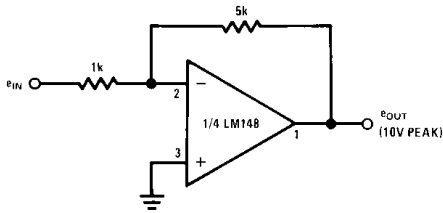

00778606

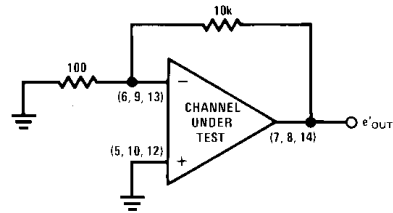

00778607

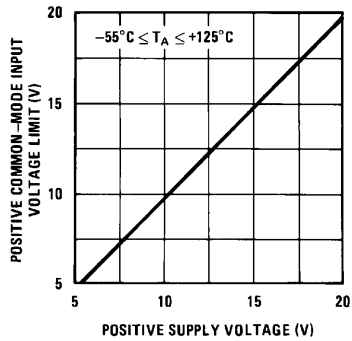

00778643

Typical Performance Characteristics

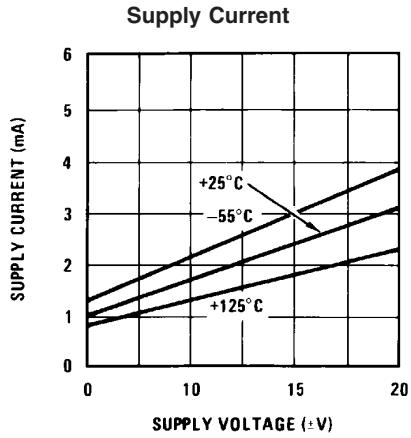

00778623

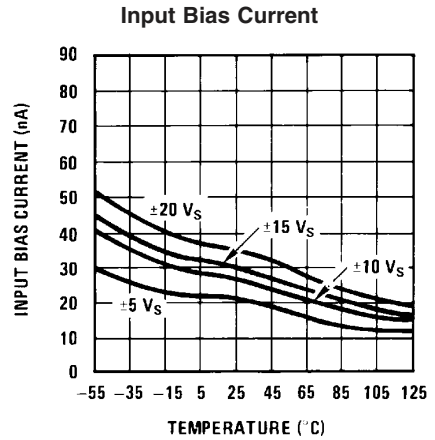

00778624

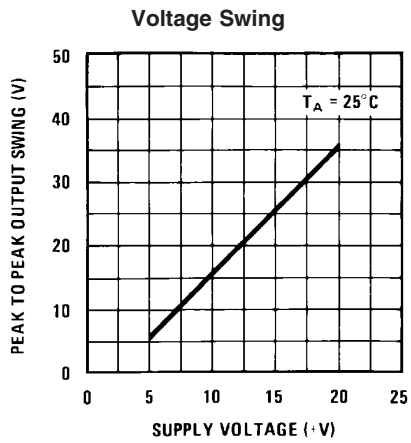

00778625

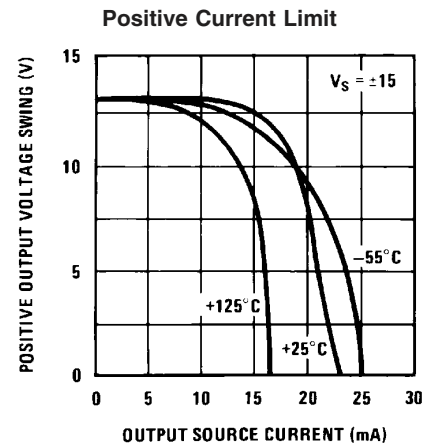

00778626

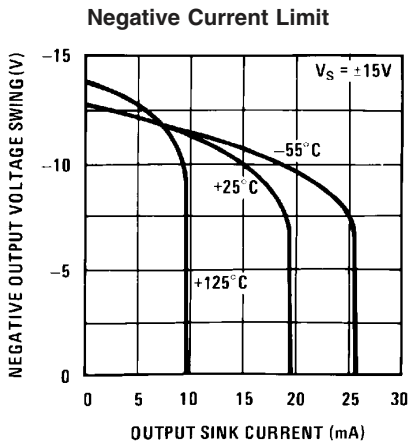

00778627

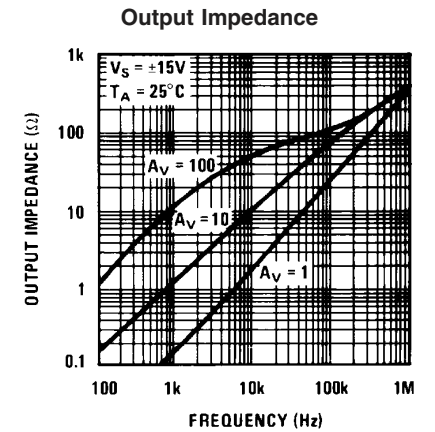

00778628

Typical Performance Characteristics (Continued)

Common-Mode Rejection Ratio

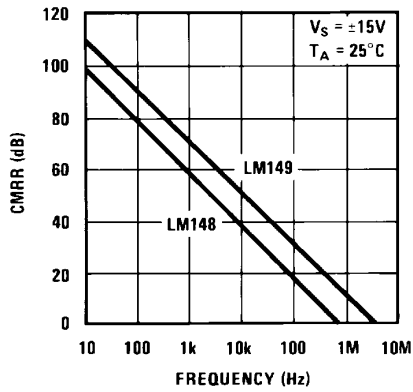

00778629

Open Loop Frequency Response

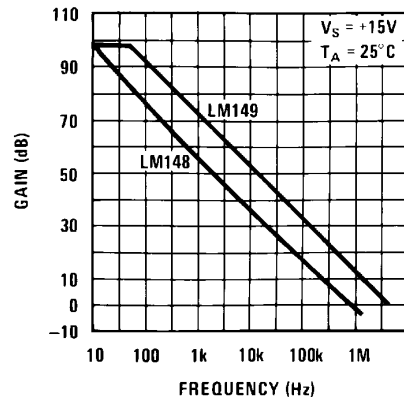

00778630

Bode Plot LM148

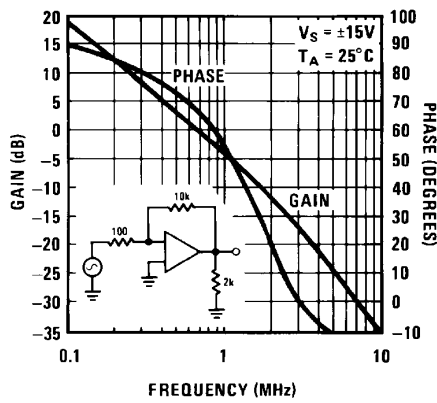

00778631

Large Signal Pulse Response (LM148)

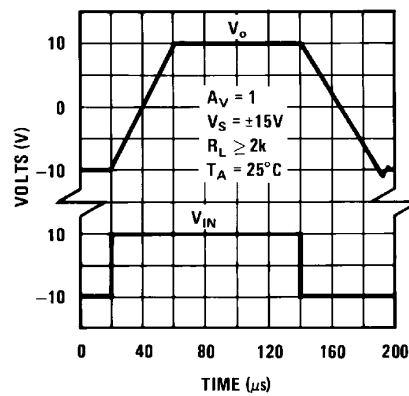

00778633

Small Signal Pulse Response (LM148)

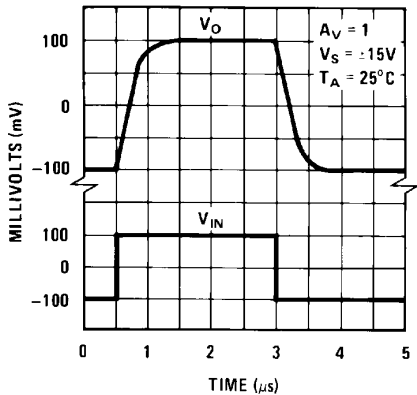

00778635

Undistorted Output Voltage Swing

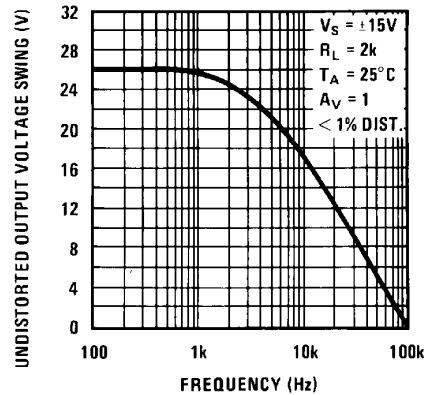

00778637

Typical Performance Characteristics (Continued)

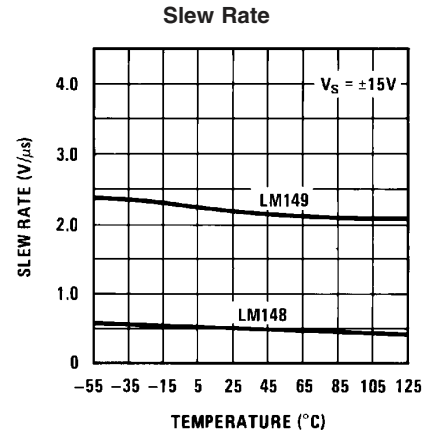
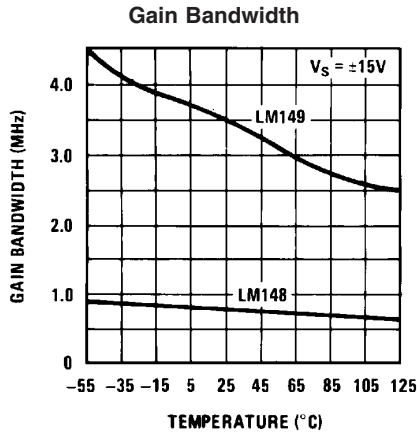

Inverting Large Signal Pulse Response (LM148)

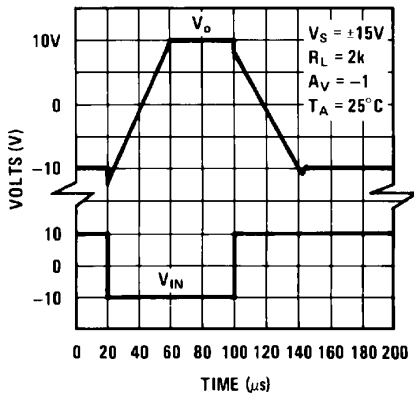

Input Noise Voltage and Noise Current

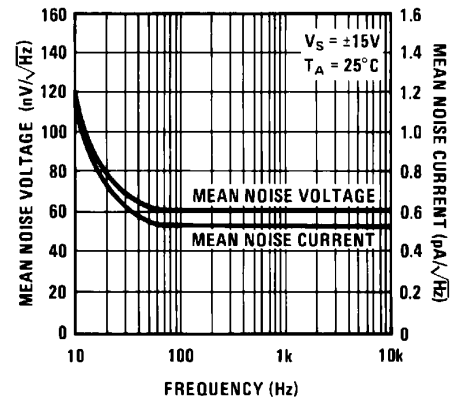

Positive Common-Mode Input Voltage Limit

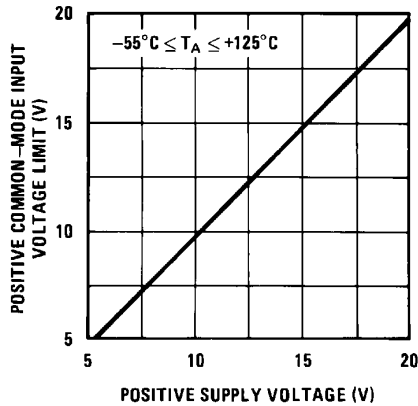

Negative Common-Mode Input Voltage Limit

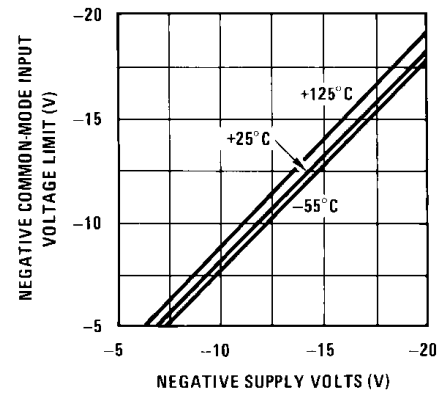

Application Hints

The LM148 series are quad low power 741 op amps. In the proliferation of quad op amps, these are the first to offer the convenience of familiar, easy to use operating characteristics of the 741 op amp. In those applications where 741 op amps have been employed, the LM148 series op amps can be employed directly with no change in circuit performance.

The package pin-outs are such that the inverting input of each amplifier is adjacent to its output. In addition, the amplifier outputs are located in the corners of the package which simplifies PC board layout and minimizes package related capacitive coupling between amplifiers.

The input characteristics of these amplifiers allow differential input voltages which can exceed the supply voltages. In addition, if either of the input voltages is within the operating common-mode range, the phase of the output remains correct. If the negative limit of the operating common-mode range is exceeded at both inputs, the output voltage will be positive. For input voltages which greatly exceed the maximum supply voltages, either differentially or common-mode, resistors should be placed in series with the inputs to limit the current.

Like the LM741, these amplifiers can easily drive a 100 pF capacitive load throughout the entire dynamic output voltage and current range. However, if very large capacitive loads must be driven by a non-inverting unity gain amplifier, a resistor should be placed between the output (and feedback connection) and the capacitance to reduce the phase shift resulting from the capacitive loading.

The output current of each amplifier in the package is limited. Short circuits from an output to either ground or the power supplies will not destroy the unit. However, if multiple output shorts occur simultaneously, the time duration should be short to prevent the unit from being destroyed as a result of excessive power dissipation in the IC chip.

As with most amplifiers, care should be taken lead dress, component placement and supply decoupling in order to ensure stability. For example, resistors from the output to an input should be placed with the body close to the input to minimize "pickup" and maximize the frequency of the feedback pole which capacitance from the input to ground creates.

A feedback pole is created when the feedback around any amplifier is resistive. The parallel resistance and capacitance from the input of the device (usually the inverting input) to AC ground set the frequency of the pole. In many instances the frequency of this pole is much greater than the expected 3 dB frequency of the closed loop gain and consequently there is negligible effect on stability margin. However, if the feedback pole is less than approximately six times the expected 3 dB frequency a lead capacitor should be placed from the output to the input of the op amp. The value of the added capacitor should be such that the RC time constant of this capacitor and the resistance it parallels is greater than or equal to the original feedback pole time constant.

Typical Applications—LM148

One Decade Low Distortion Sinewave Generator

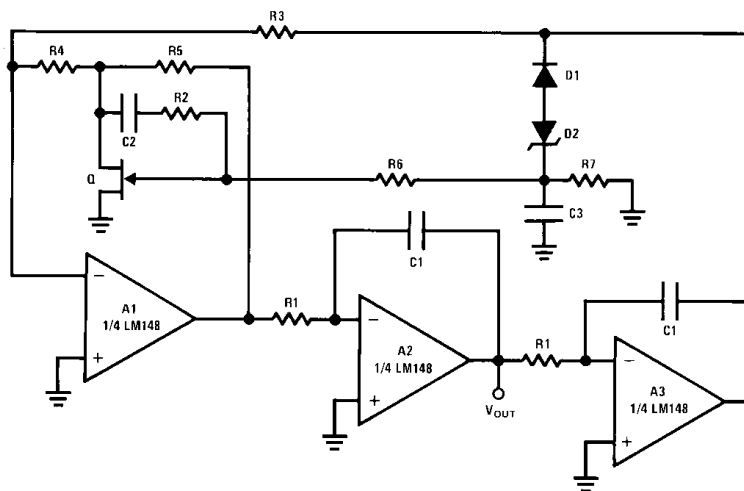

00778608

$$f = \frac{1}{2\pi R_1 C_1} \times \sqrt{K}, K = \frac{R_4 R_5}{R_3} \left(\frac{1}{r_{DS}} + \frac{1}{R_4} + \frac{1}{R_5} \right), r_{DS} \approx \frac{R_{ON}}{\left(1 - \frac{V_{GS}}{V_P} \right)^{1/2}}$$

$f_{MAX} = 5 \text{ kHz}$, THD $\leq 0.03\%$

$R_1 = 100\text{k pot}$, $C_1 = 0.0047 \mu\text{F}$, $C_2 = 0.01 \mu\text{F}$, $C_3 = 0.1 \mu\text{F}$, $R_2 = R_6 = R_7 = 1\text{M}$,
 $R_3 = 5.1\text{k}$, $R_4 = 12\Omega$, $R_5 = 240\Omega$, $Q = \text{NS5102}$, $D_1 = 1\text{N914}$, $D_2 = 3.6\text{V avalanche}$
 diode (ex. LM103), $V_S = \pm 15\text{V}$

A simpler version with some distortion degradation at high frequencies can be made by using A1 as a simple inverting amplifier, and by putting back to back zeners in the feedback loop of A3.

Typical Applications—LM148 (Continued)

Low Cost Instrumentation Amplifier

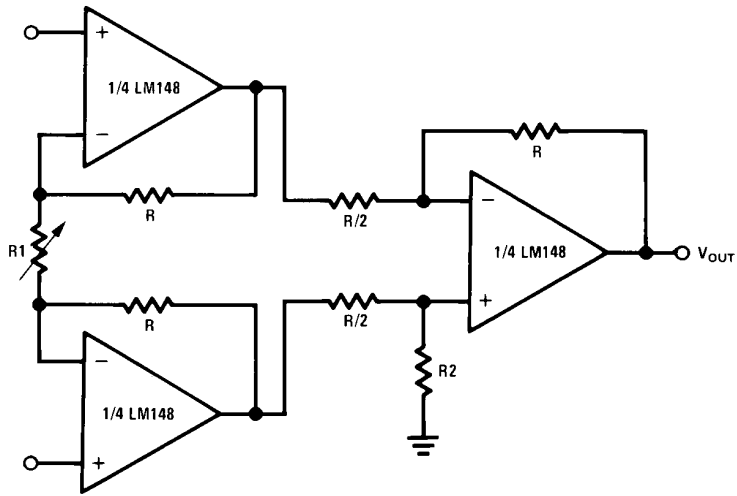

00778609

$$V_{OUT} = 2 \left(\frac{2R}{R1} + 1 \right) \cdot V_S - 3V \leq V_{IN\ CM} < V_S^+ - 3V,$$

$V_S = \pm 15V$

$R = R2$, trim $R2$ to boost CMRR

Low Drift Peak Detector with Bias Current Compensation

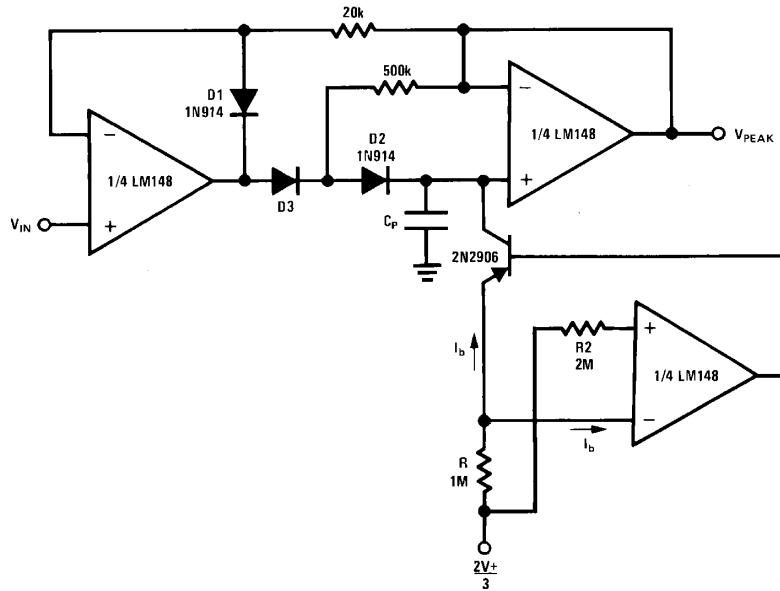

00778610

Adjust R for minimum drift
 D3 low leakage diode
 D1 added to improve speed
 $V_S = \pm 15V$

Typical Applications—LM148 (Continued)

Universal State-Variable Filter

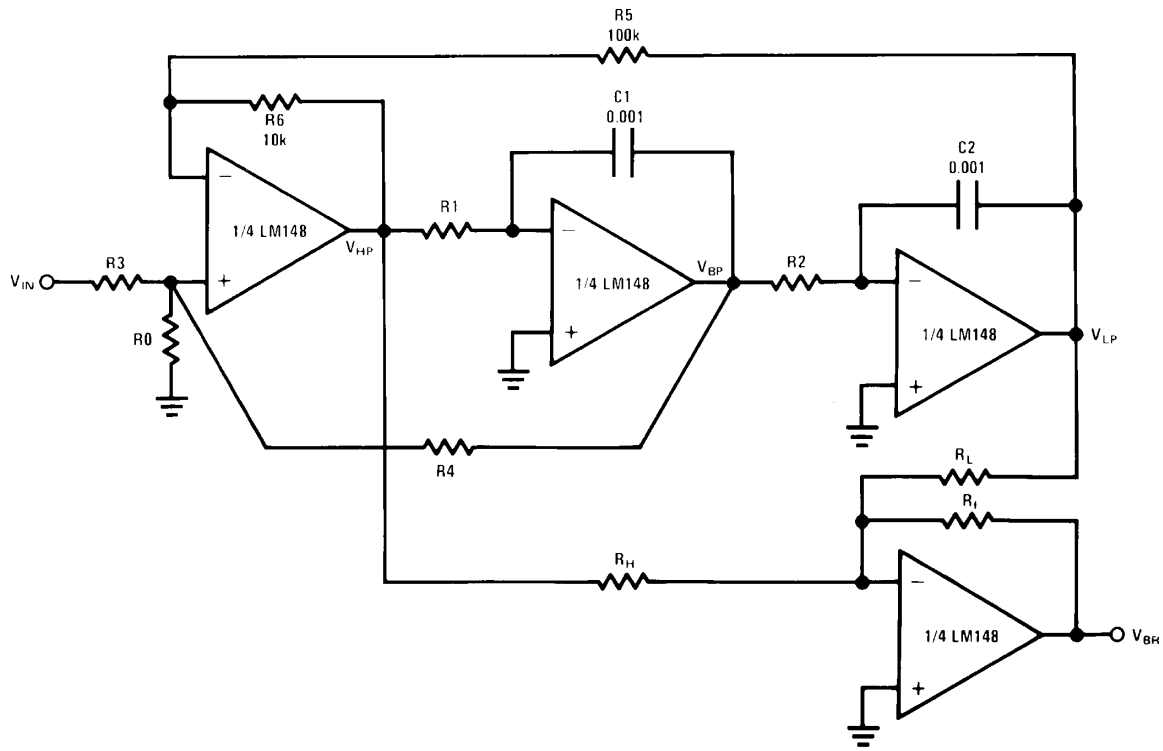

00778611

Tune Q through R0,

For predictable results: $f_o Q \leq 4 \times 10^4$

Use Band Pass output to tune for Q

$$\frac{V(s)}{V_{IN}(s)} = \frac{N(s)}{D(s)}, D(s) = s^2 + \frac{s\omega_o}{Q} + \omega_o^2$$

$$N_{HP}(s) = s^2 H_{OHP}, N_{BP}(s) = \frac{s\omega_o H_{OBP}}{Q}, N_{LP} = \omega_o^2 H_{OLP}$$

$$f_o = \frac{1}{2\pi} \sqrt{\frac{R6}{R5}} \sqrt{\frac{1}{t_1 t_2}}, t_1 = R_1 C_1, Q = \left(\frac{1 + R4/R3 + R4/R0}{1 + R6/R5} \right) \left(\frac{R6 t_1}{R5 t_2} \right)^{1/2}$$

$$f_{NOTCH} = \frac{1}{2\pi} \left(\frac{R_H}{R_L t_1 t_2} \right)^{1/2}, H_{OHP} = \frac{1 + R6/R5}{1 + R3/R0 + R3/R4}, H_{OBP} = \frac{1 + R4/R3 + R4/R0}{1 + R3/R0 + R3/R4}$$

$$H_{OLP} = \frac{1 + R5/R6}{1 + R3/R0 + R3/R4}$$

Typical Applications—LM148 (Continued)

A 1 kHz 4 Pole Butterworth

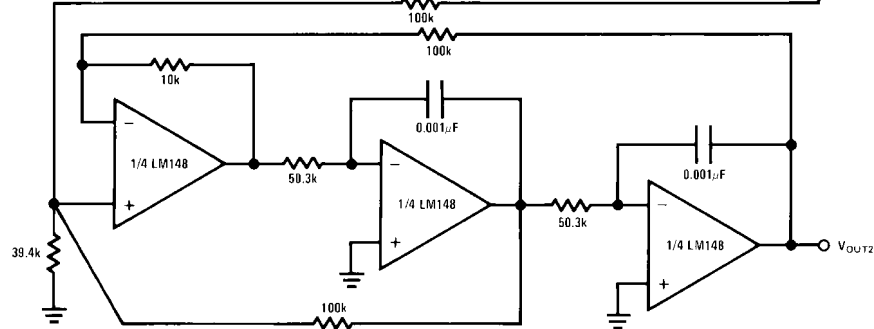
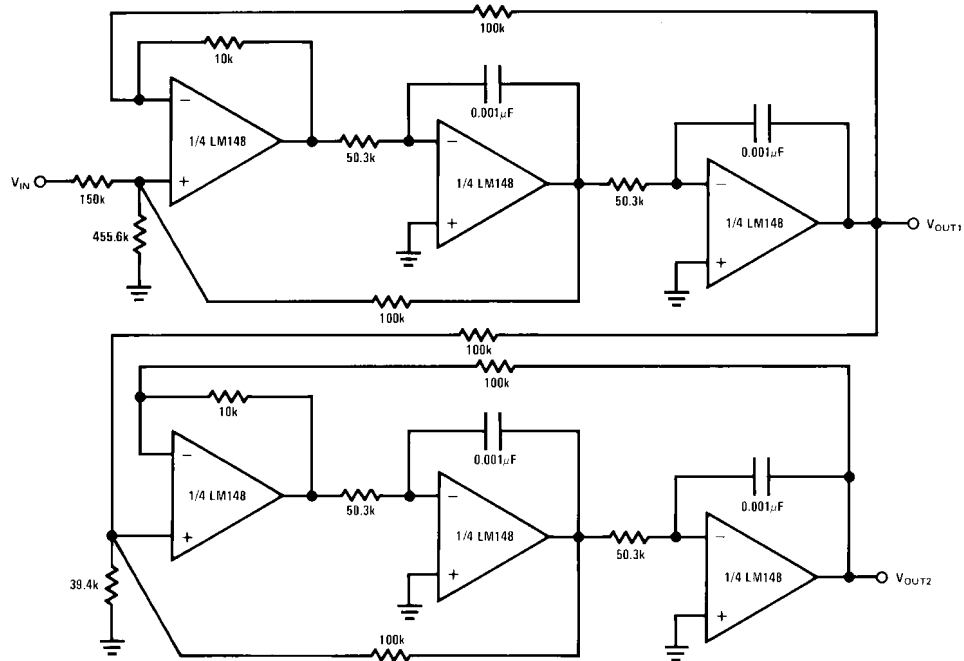

Use general equations, and tune each section separately

$Q_{1stSECTION} = 0.541$, $Q_{2ndSECTION} = 1.306$

The response should have 0 dB peaking

00778612

A 3 Amplifier Bi-Quad Notch Filter

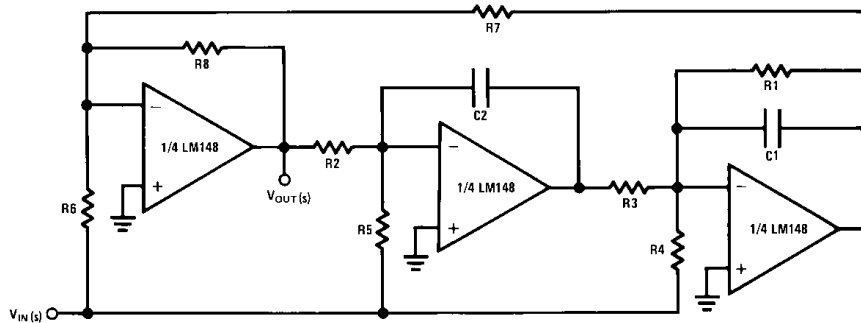

00778613

$$Q = \sqrt{\frac{R8}{R7}} \times \frac{R1C1}{\sqrt{R3C2R2C1}}, \quad f_o = \frac{1}{2\pi} \sqrt{\frac{R8}{R7}} \times \frac{1}{\sqrt{R2R3C1C2}}, \quad f_{NOTCH} = \frac{1}{2\pi} \sqrt{\frac{R6}{R3R5R7C1C2}}$$

$$\text{Necessary condition for notch: } \frac{1}{R6} = \frac{R1}{R4R7}$$

Ex: $f_{NOTCH} = 3 \text{ kHz}$, $Q = 5$, $R1 = 270k$, $R2 = R3 = 20k$, $R4 = 27k$, $R5 = 20k$, $R6 = R8 = 10k$, $R7 = 100k$, $C1 = C2 = 0.001 \mu\text{F}$

Better noise performance than the state-space approach.

Typical Applications—LM148 (Continued)

A 4th Order 1 kHz Elliptic Filter (4 Poles, 4 Zeros)

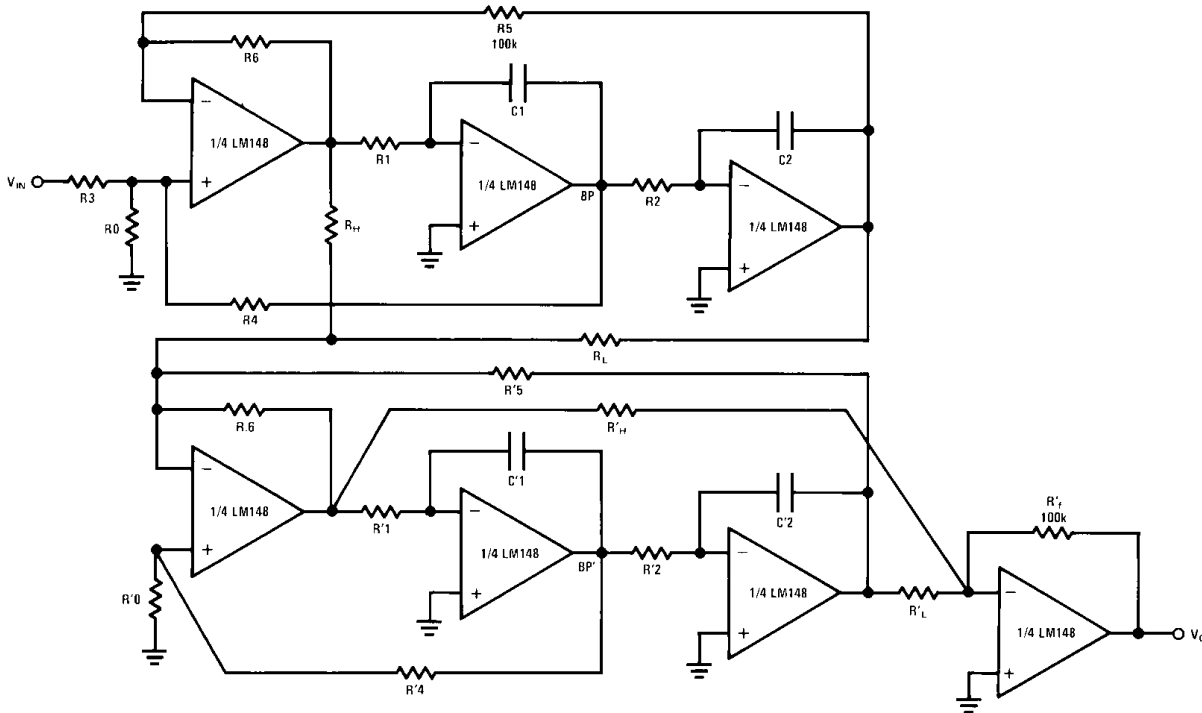

00778614

$R_1C_1 = R_2C_2 = t$
 $R'_1C'_1 = R'_2C'_2 = t'$

$f_C = 1 \text{ kHz}$, $f_S = 2 \text{ kHz}$, $f_P = 0.543$, $f_Z = 2.14$, $Q = 0.841$, $f'_P = 0.987$, $f'_Z = 4.92$, $Q' = 4.403$, normalized to ripple BW

$$f = \frac{1}{2\pi R_1 C_1} \times \sqrt{K}, K = \frac{R_4 R_5}{R_3} \left(\frac{1}{r_{DS}} + \frac{1}{R_4} + \frac{1}{R_5} \right), r_{DS} \approx \frac{R_{ON}}{\left(1 - \frac{V_{GS}}{V_P} \right)^{1/2}}$$

Use the BP outputs to tune Q, Q', tune the 2 sections separately

$R_1 = R_2 = 92.6k$, $R_3 = R_4 = R_5 = 100k$, $R_6 = 10k$, $R_0 = 107.8k$, $R_L = 100k$, $R_H = 155.1k$,

$R'_1 = R'_2 = 50.9k$, $R'_4 = R'_5 = 100k$, $R'_6 = 10k$, $R'_0 = 5.78k$, $R'_L = 100k$, $R'_H = 248.12k$, $R'_f = 100k$. All capacitors are $0.001 \mu F$.

Lowpass Response

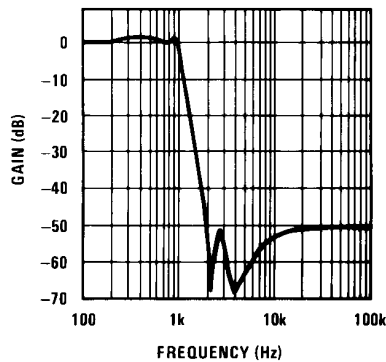

00778615

Typical Simulation

LM148, LM741 Macromodel for Computer Simulation

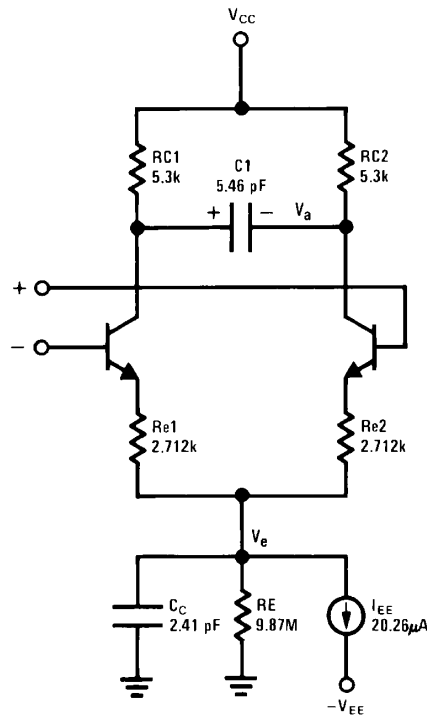

00778621

For more details, see IEEE Journal of Solid-State Circuits, Vol. SC-9, No. 6, December 1974

Note 6: $\omega_1 = 112|S = 8 \times 10^{-16}$

Note 7: $\omega_2 = 144^{\circ}C2 = 6 \text{ pF}$ for LM149

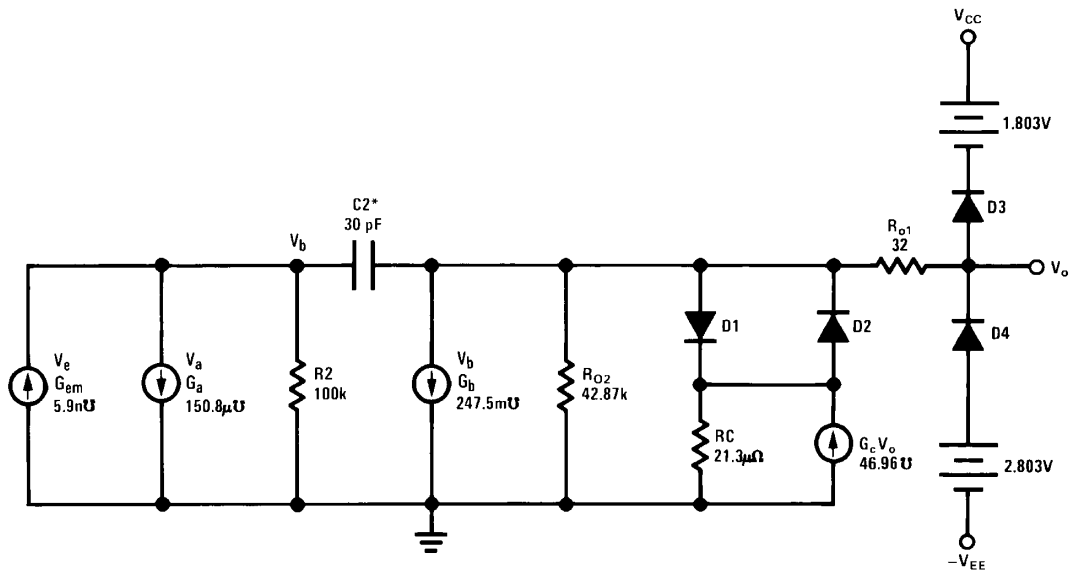

00778622

Connection Diagram

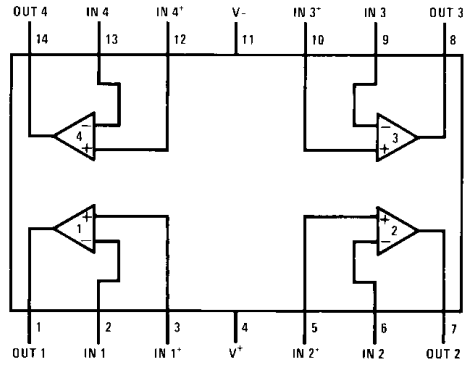

00778602

Top View

Order Number LM148J, LM148J/883, LM248J, LM348M, or LM348N
 See NS Package Number J14A, M14A or N14A
 LM148J is available per JM38510/11001

Physical Dimensions inches (millimeters)

unless otherwise noted

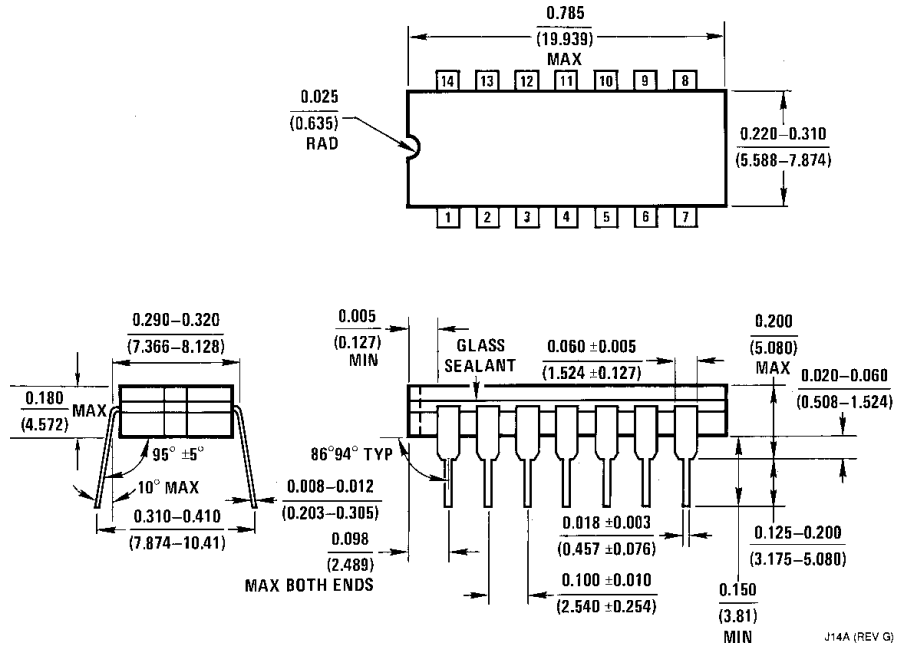

Ceramic Dual-In-Line Package (J)
 Order Number LM148J, LM148J/883, LM248J
 NS Package Number J14A

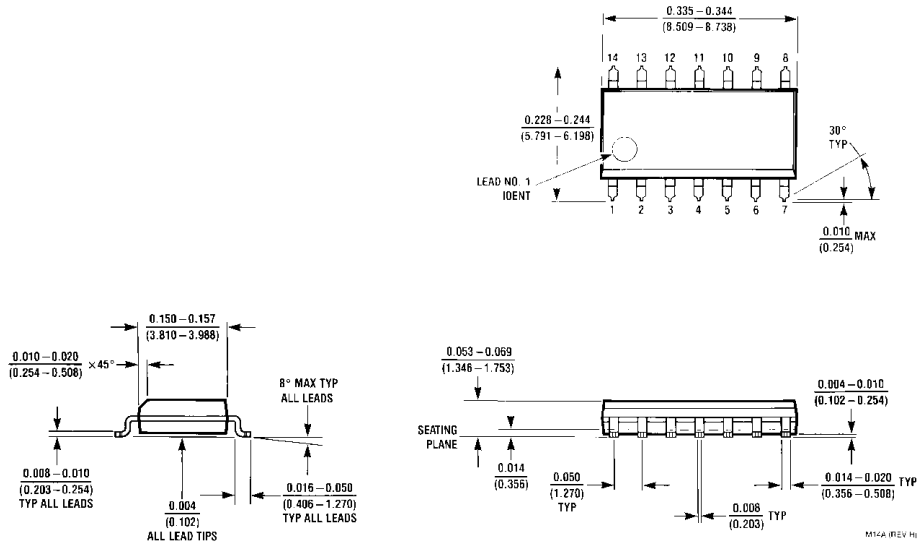

S.O. Package (M)
 Order Number LM348M or LM348MX
 NS Package Number M14A

Physical Dimensions inches (millimeters) unless otherwise noted (Continued)

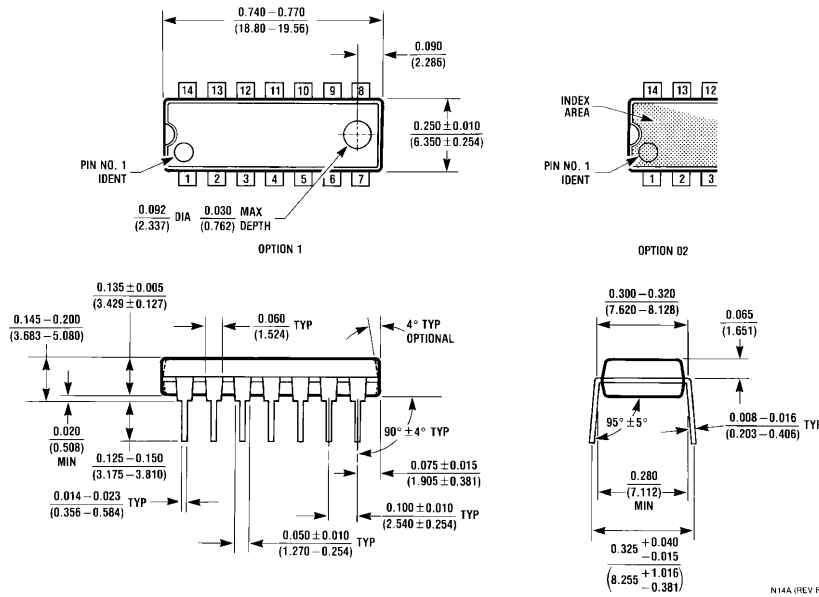

Molded Dual-In-Line Package (N)
Order Number LM348N
NS Package Number N14A

LIFE SUPPORT POLICY

NATIONAL'S PRODUCTS ARE NOT AUTHORIZED FOR USE AS CRITICAL COMPONENTS IN LIFE SUPPORT DEVICES OR SYSTEMS WITHOUT THE EXPRESS WRITTEN APPROVAL OF THE PRESIDENT AND GENERAL COUNSEL OF NATIONAL SEMICONDUCTOR CORPORATION. As used herein:

1. Life support devices or systems are devices or systems which, (a) are intended for surgical implant into the body, or (b) support or sustain life, and whose failure to perform when properly used in accordance with instructions for use provided in the labeling, can be reasonably expected to result in a significant injury to the user.
2. A critical component is any component of a life support device or system whose failure to perform can be reasonably expected to cause the failure of the life support device or system, or to affect its safety or effectiveness.

BANNED SUBSTANCE COMPLIANCE

National Semiconductor certifies that the products and packing materials meet the provisions of the Customer Products Stewardship Specification (CSP-9-111C2) and the Banned Substances and Materials of Interest Specification (CSP-9-111S2) and contain no "Banned Substances" as defined in CSP-9-111S2.



National Semiconductor
Americas Customer Support Center
 Email: new.feedback@nsc.com
 Tel: 1-800-272-9959

National Semiconductor
Europe Customer Support Center
 Fax: +49 (0) 180-530 85 86
 Email: europe.support@nsc.com
 Deutsch Tel: +49 (0) 69 9508 6208
 English Tel: +44 (0) 870 24 0 2171
 Français Tel: +33 (0) 1 41 91 8790

National Semiconductor
Asia Pacific Customer Support Center
 Email: ap.support@nsc.com

National Semiconductor
Japan Customer Support Center
 Fax: 81-3-5639-7507
 Email: jpn.feedback@nsc.com
 Tel: 81-3-5639-7560

www.national.com