

PROPER USE GUIDELINES

Cumulative Trauma Disorders can result from the prolonged use of manually powered hand tools. AMP hand tools are intended for occasional use and low volume applications. AMP offers a wide selection of powered application equipment for extended use.

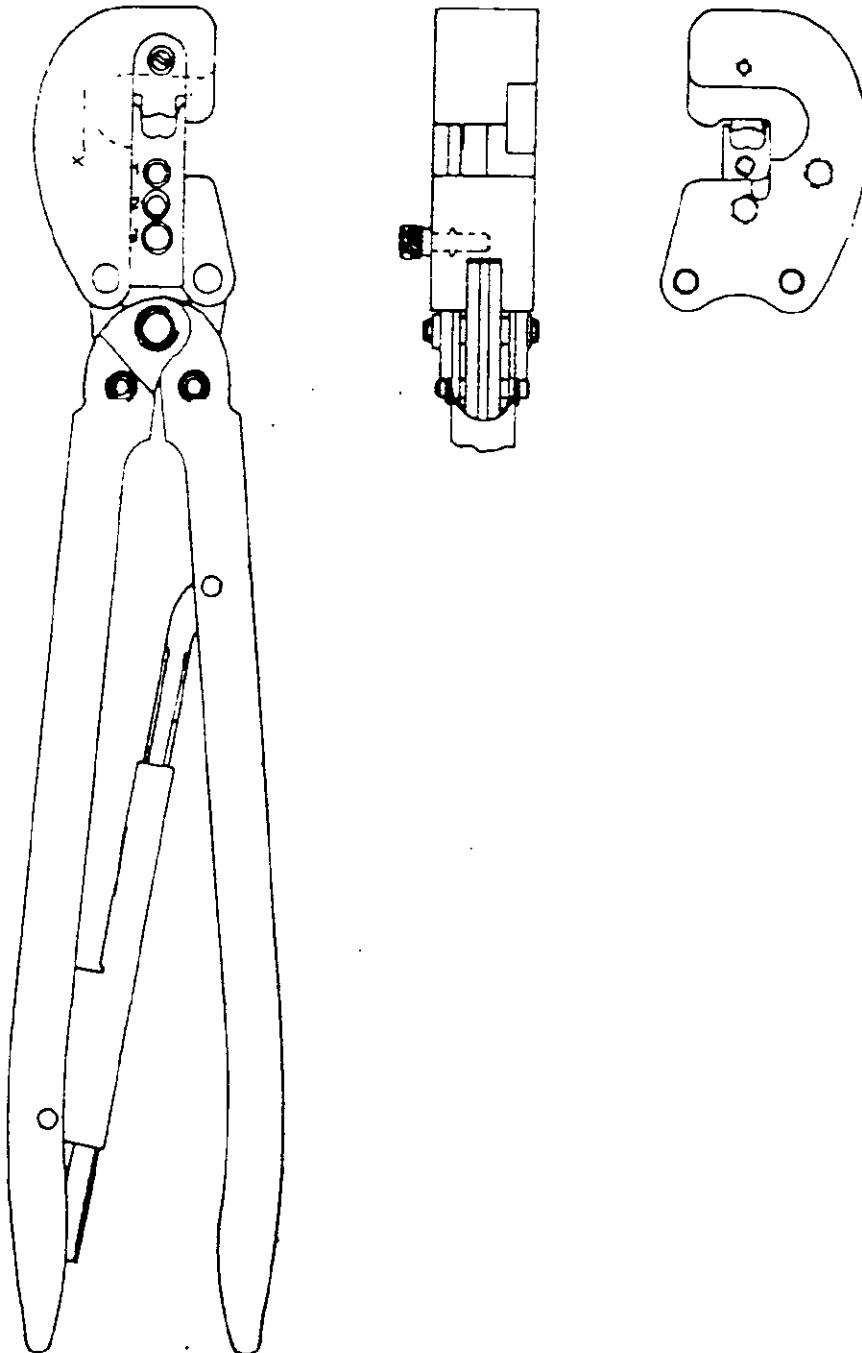

1. INTRODUCTION

NOTE

This tool is designed primarily for field installation, repair, maintenance work, or prototyping in industrial, commercial, or institutional applications. AMP offers a variety of tools to satisfy your performance requirements.

AMP hand application Tool P/N 781032-0 is designed to crimp the AMP P/Ns 280526 and 280528 double tab and receptacle contacts listed in table figure 1. Read these instructions thoroughly before crimping any contacts. The tool is recommended for field repair use.

2. DESCRIPTION

The tool features two crimp sections, a contact locator, wire stop, and ratchet to ensure full contact crimping.

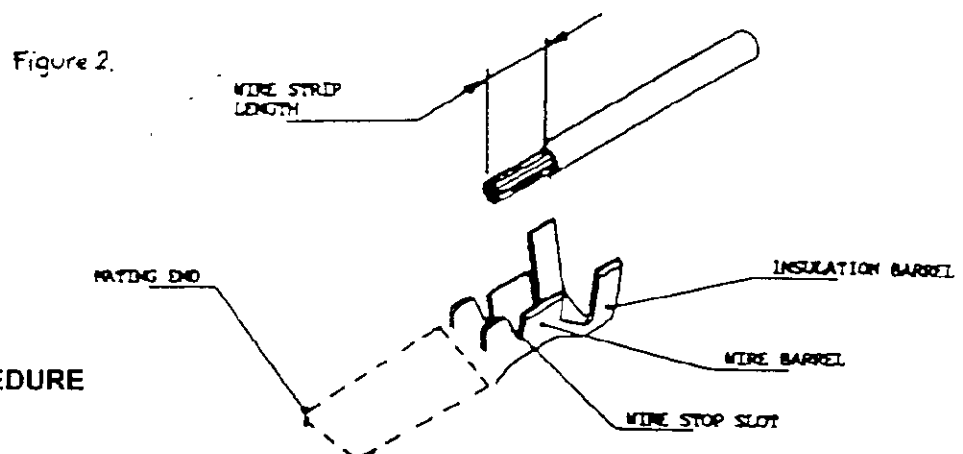

3. CRIMPING PROCEDURE

NOTE

This tool is provided with a crimp adjustment feature. Initially, the crimp height should be verified as specified in Figure 4. Refer to section 4, MAINTENANCE/INSPECTION, Paragraph C, Crimp Height Inspection and Paragraph D, Adjustment, to verify crimp height before using the tool to crimp desired contact and wire sizes.

Refer to table in Figure 4 and select wire of the specified: size, insulation diameter, strip length, taking care not to nick or cut wire strands. Select an applicable contact and identify the appropriate crimp section according to the wire size marking on the tool. Refer to Figure 2 and proceed as follows:

1. Hold the tool so that the back (wire side) is facing you. Squeeze tool handles together and allow them to open fully.
2. Holding the contact by the insulation barrel, insert it - receptacle/tab end first - through the back of the tool and into the appropriate wire crimp section.

NOTE

Contact must be inserted with the open side of insulation and wire barrel positioned toward the movable crimping jaw.

3. Align contact wire stop slot with the wire stop in the crimping jaws. The contact insulation and wire barrels must be positioned in the crimp section as shown in Figure 3.

NOTE

Make sure both sides of the insulation barrel are started evenly into the crimper jaws. Do NOT attempt to crimp an improperly positioned contact.

Figure 3.

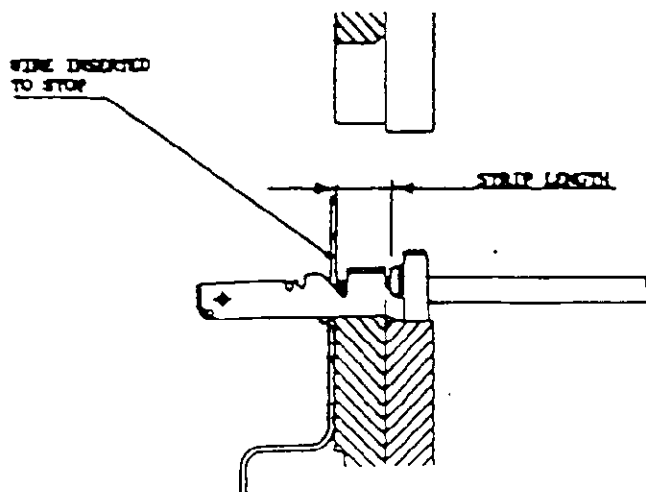

4. Squeeze tool handles together until ratchet engages sufficiently to hold the contact in position. Do NOT deform insulation barrel or wire barrel.
5. Insert stripped wire into contact insulation and wire barrels until it is butted against the wire stop.
6. Holding the wire in place, squeeze tool handles together until ratchet releases. Allow tool handles to open and remove crimped contact.

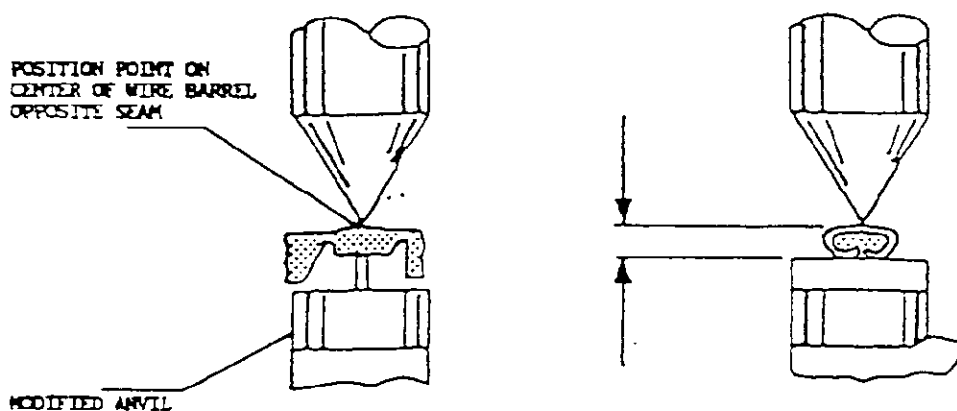

CONTACT P/Ns	WIRE SIZE mm ²	CRIMP HEIGHT DIMENSION
280526 280528	0.5-1.0	.054 ± .002

Figure4

4. MAINTENANCE/INSPECTION

A. Maintenance

Ensure that the tool and dies are clean by wiping them with a clean, soft cloth. Remove any debris with a clean, soft brush. Do not use objects that could damage the tool. When not in use, keep handles closed to prevent objects from becoming lodged in the crimping dies, and store in a clean, dry area

B. Visual Inspection

The crimping dies should be inspected on a regular basis to ensure that they have not become worn or damaged. Inspect the crimp sections for flattened, chipped, worn, or broken areas. If damage or abnormal wear is evident, the tool must be replaced.

C. Crimp Height Inspection

This inspection requires the use of a micrometer with a modified anvil.

Proceed as follows:

1. Refer to the table in Figure 4, and select a contact and wire for crimp section listed.
2. Refer to Paragraph 3, CRIMPING PROCEDURE, and crimp the contact(s) accordingly.
3. Using a crimp height comparator, measure wire barrel crimp height as shown in Figure 4. If the tool must be adjusted, see Paragraph D, Adjustment.

D. Adjustment (figure 5)

1. Remove the button head lockscrew from the ratchet adjustment wheel.
2. Adjust the ratchet wheel from the locator side of the tool.
3. Observe the ratchet adjustment wheel and turn it in the appropriate direction to obtain a tighter or looser setting.
4. Crimp a test sample and measure crimped height. If the dimension is acceptable, replace and secure the lockscrew. If the dimension is unacceptable, continue to adjust the ratchet and again measure a test sample.

