

SPEAKER-1115-SC-NAUTILUS 180

The 11x15x4.0 Nautilus speaker features the state-of-the-art side-firing technology. It provides a lateral sound outlet, which is already integrated in the cover of the speaker.

The usage of the Nautilus speaker significantly saves height in mobile phone architectures. Conventional side-ported designs always need additional air channels, which increase the thickness of the total speaker application.

The Nautilus speaker provides the proven acoustic performance of the industry standard 11x15x3.5 speaker.



Features:

- Lateral sound outlet at total height of only 4mm
- Low resonance frequency (750Hz)
- 500 mw power handling capacity
- Very robust spring connectors
- 100% in-line measurement of all specified electrical and acoustical parameters

2403 260 00089

Contents

1. Theory of operation.....	3
2. Mechanical Layout and Dimensions.....	4
2.1. Main Dimensions.....	4
2.2. PWB Layout	5
2.3. Spring Force.....	5
2.4. Force layout.....	6
Material list.....	7
3. Part marking	7
4. Electro-Acoustic characteristics	8
4.1. Frequency response and THD	8
4.1. Electro acoustic characteristics acc. IEC 268-5.....	9
4.2. Power handling.....	9
4.3. Measurement setup	10
4.4. Measured Parameters.....	10
4.5. Measurement adapter 1 cm ³	11
5. Environmental Conditions	12
5.1. Storage.....	12
5.2. Transportation.....	12
5.3. Functionality.....	12
6. Environmental tests	13
6.1. Qualification tests.....	13
6.2. Reliability tests	13
6.3. Sample Size, Sequence	13
6.4. Period of Shelf-Life	13
6.5. Testing Procedures.....	13
7. Related Documents	17
8. Change History	18
9. Disclaimer	18



2403 260 00089

1. Theory of operation

SPEAKER-1115-SC-NAUTILUS 180 delivers maximum space efficiency and audio performance in small, slim consumer devices with lateral sound outlet, such as mobile handsets or smartphones.

2403 260 00089

2. Mechanical Layout and Dimensions

2.1. Main Dimensions

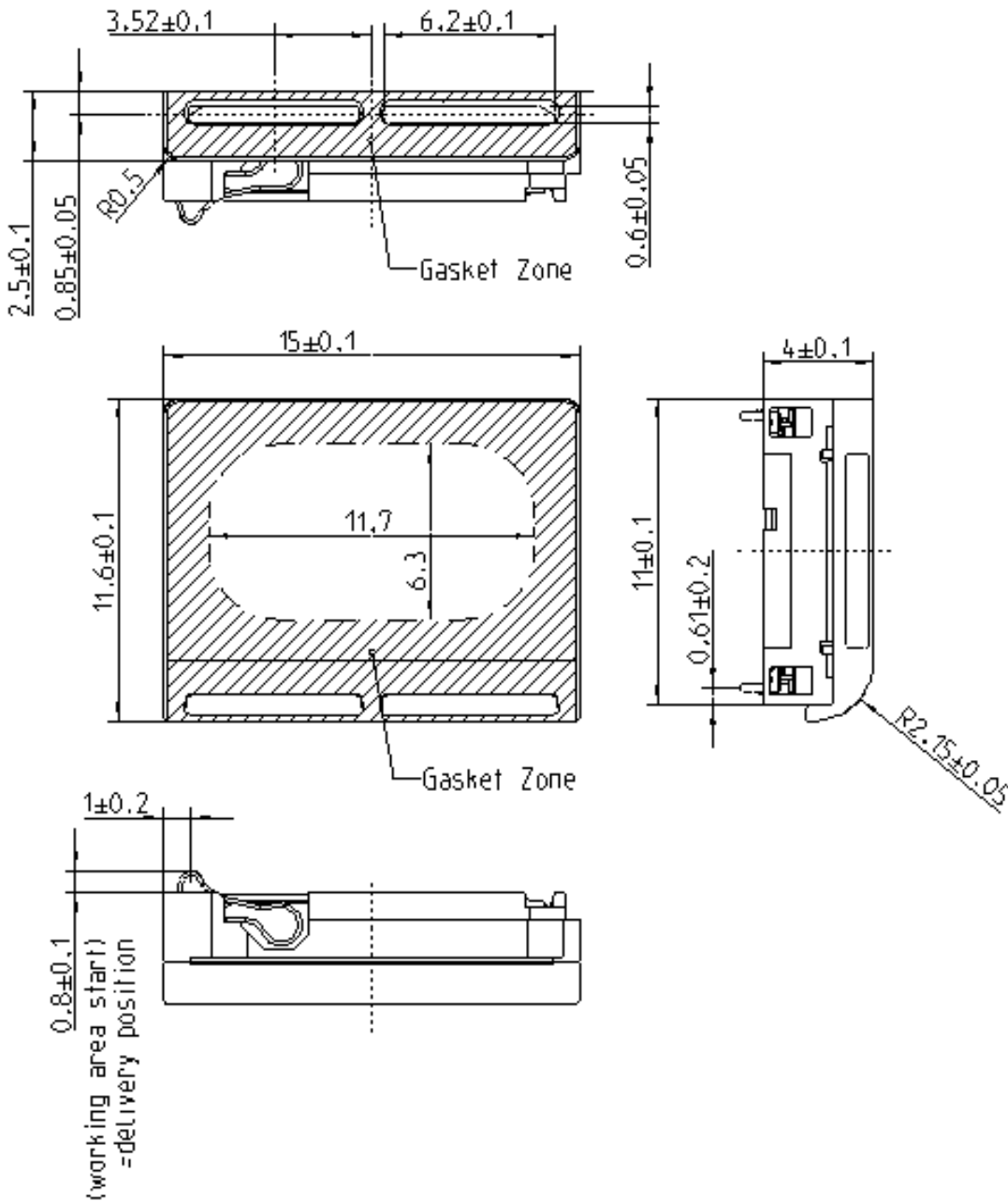

The gasket zone just defines the possible area for a gasket. For a detailed gasket recommendation refer to APN0xx.

2403 260 00089

2.2. PWB Layout

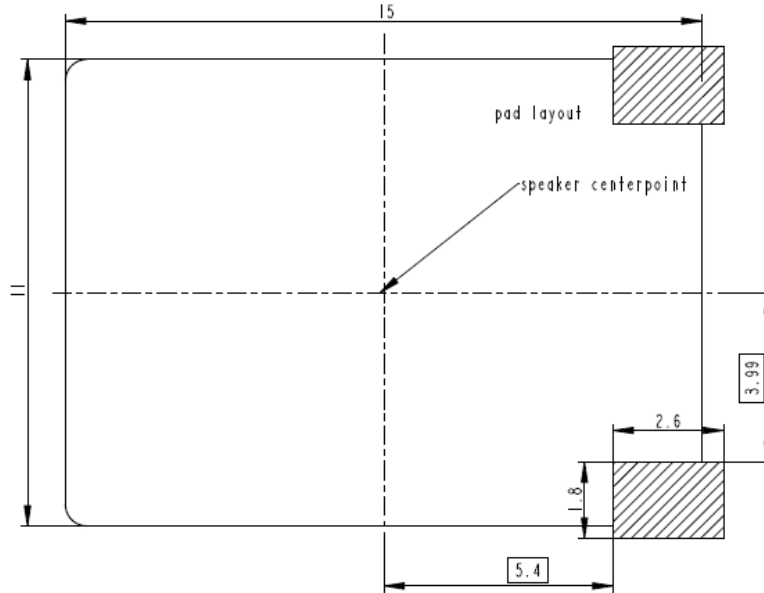

2.3. Spring Force

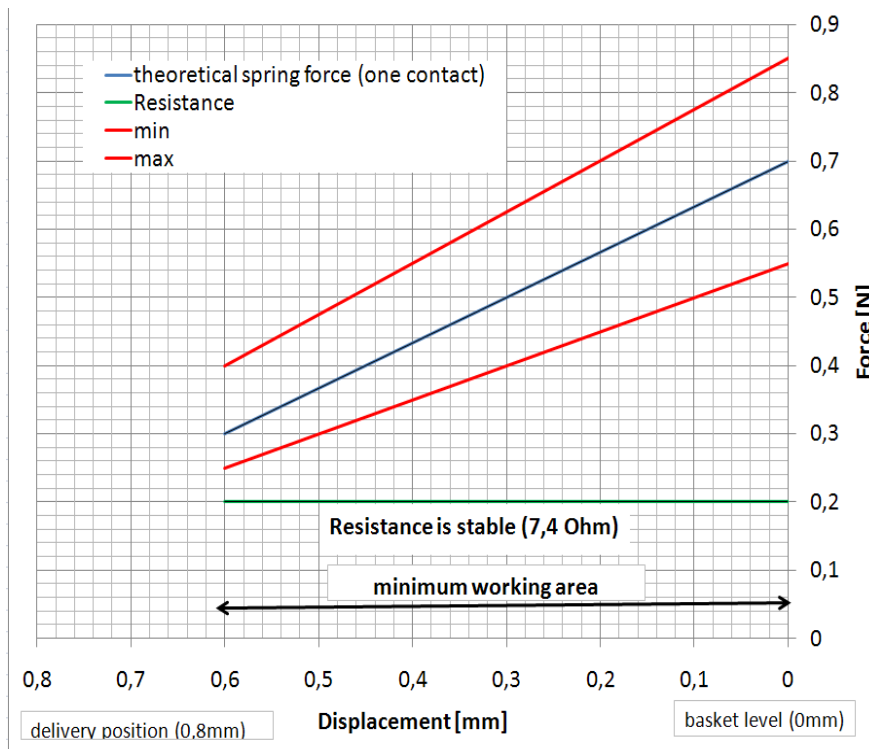

2403 260 00089

2.4. Force layout

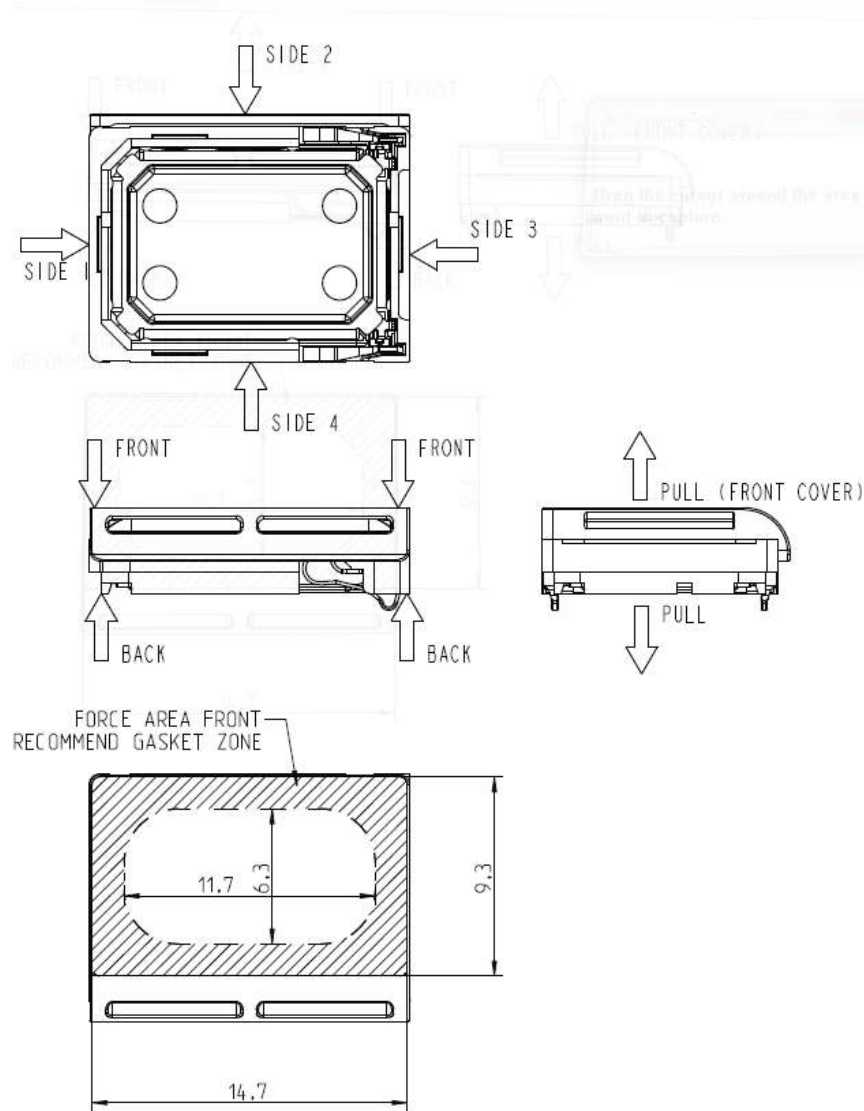

STATICAL FORCES ON DIFFERENT STATES OF COMPONENT			
STATE	MIN.SURFACE OF PREASURE [mm ²]	MAX. PERMANENT FORCE [N]	MAX. HANDLING FORCE [N]
FROM FRONT TO BACK *)	-	10	15
FROM SIDE 1 TO SIDE 3	3	10	15
FROM SIDE 2 TO SIDE 4	10	10	15
TO POT	-	10	15
PULL OFF FORCE	-	0	10
POT RETENTION FORCE (informal value for tumble test and drop test)	min. 150 **)		

*) This force can only be applied inside the recommended gasket zone!

***) This force is only valid for the pot-basket stability. The front cover is not able handle this force!

2403 260 00089

Material list

- MATERIAL of BASKET: Polycarbonate
- MATERIAL of MEMBRANE: Polyarylate-Compound
- MATERIAL of POT: soft magnetic Iron
- MATERIAL of MAGNET: Nd Fe B /N42
- MATERIAL of CONTACT: CrNi-Steel
- PLATING of CONTACT: 0.1-0.2µm Ni,
0.3-0.5µm Au (contact area)
6-12µm Sn100
- MATERIAL of COVER: Polycarbonate
- DIMENSION: 15x11x3.5mm
- MASS: 1.6g

3. Part marking

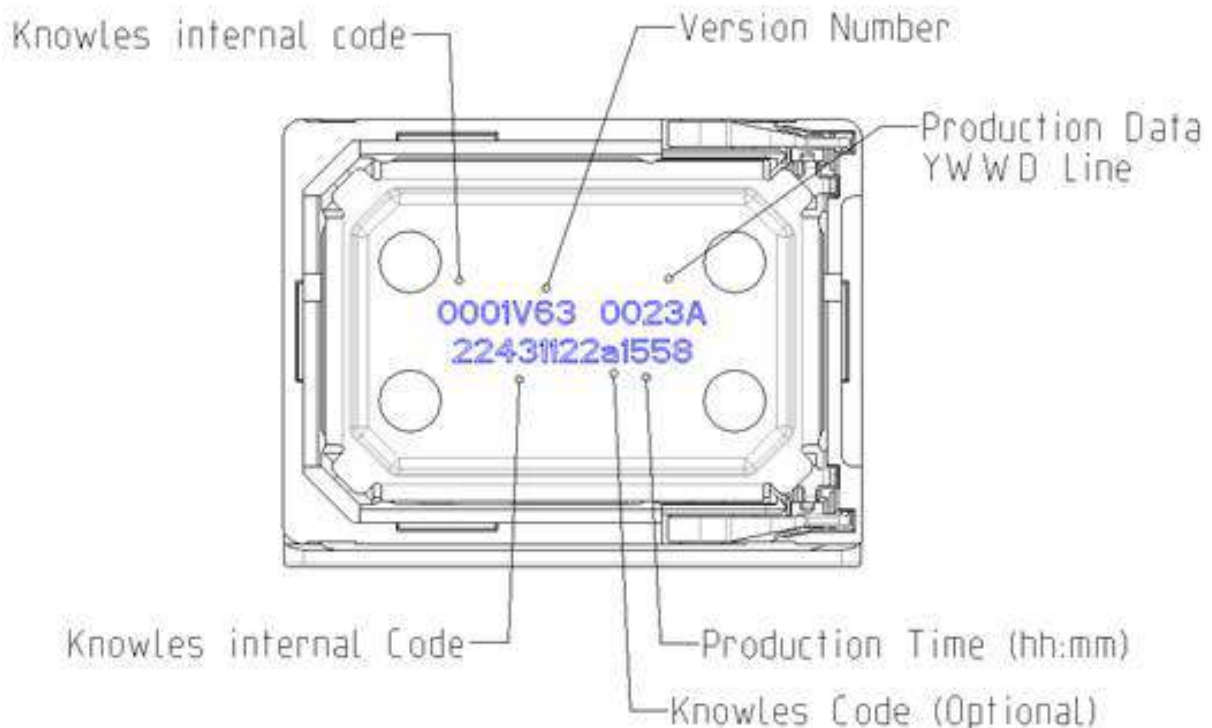

2403 260 00089

4. Electro-Acoustic characteristics

4.1. Frequency response and THD

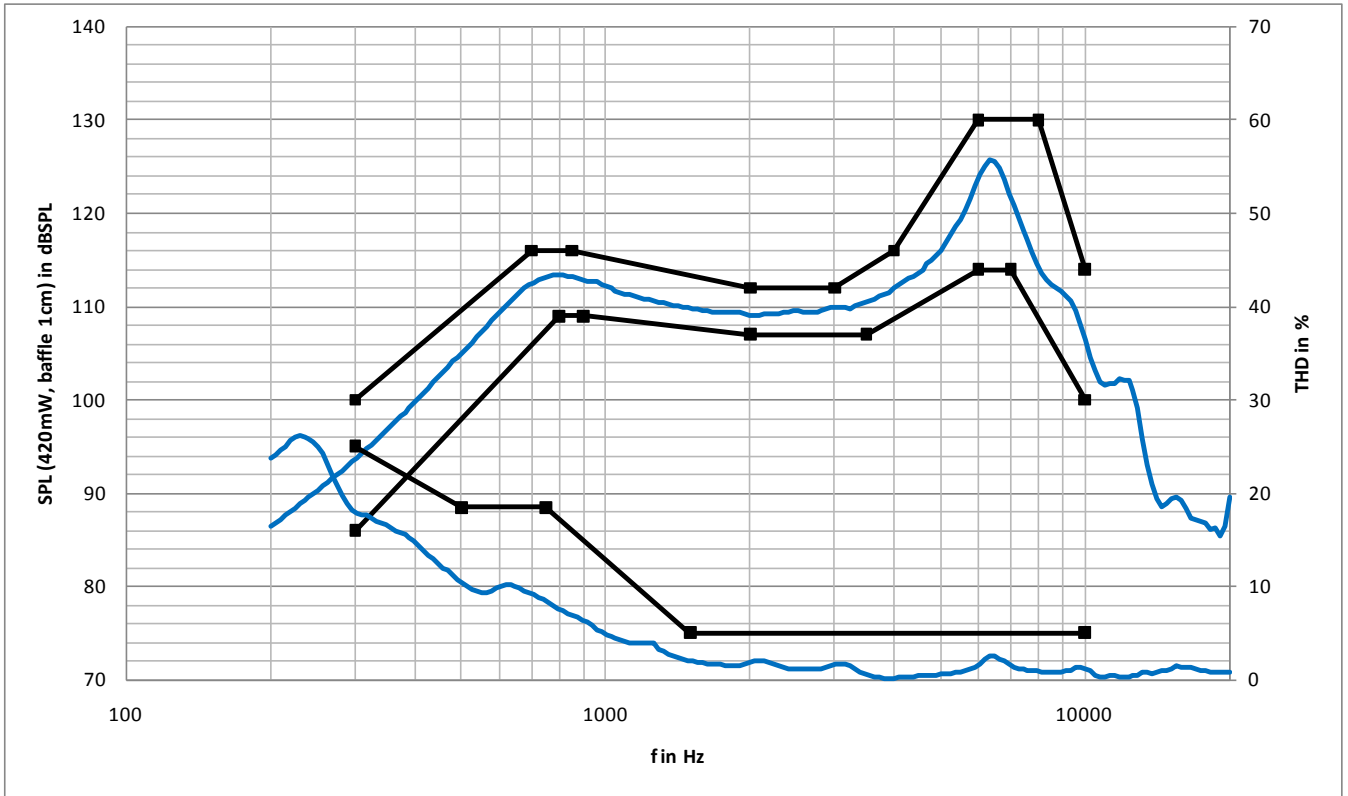

TYPICAL FREQUENCY RESPONSE AND THD
 measured in Baffle with measurement adapter acc. to chapter 5.5
 distance $d = 1\text{cm}$, back cavity 1cm^3 at 420mW

f in Hz	dB SPL lower limit (floating)	f in Hz	dB SPL upper limit (floating)
300	86	300	100
800	109	700	116
900	109	850	116
2000	107	2000	112
3500	107	3000	112
6000	114	4000	116
7000	114	6000	130
10000	100	8000	130
		10000	114

f in Hz	THD limit in %
300	25
500	18,5
750	18,5
1500	5
10000	5

2403 260 00089

4.1. Electro acoustic characteristics acc. IEC 268-5

Loudspeaker mounted in 1cm³ measurement adapter acc. to chapter 5.5

1. RATED IMPEDANCE	Z:	8Ω
2. VOICE COIL RESISTANCE	R:	7.4Ω ± 10%
3. RESONANCE FREQUENCY at 420mW	f ₀ :	750Hz ± 10%
4. MAXIMUM LINEAR EXCURSION	Xmax:	+/- 0.30mm
5. CHARACT. SENSITIVITY (1W in 1m) average from 2kHz to 3kHz		73 ± 2dB
6. THD		according to chapter 5.1
7. RUB & BUZZ		no audible rub & buzz at 420mW

4.2. Power handling

Loudspeaker mounted in lifetime test device (closed Box 1ccm, open front)

Signal: pink noise with high-pass 12dB/Oct. at 800Hz, crest factor 2, used for all operating lifetime tests

1. MAX.SHORT TERM POWER 1sec ON, 1min. OFF, 60 cycles Ambient temperature 70°C	1000mW
2. MAX LONG TERM POWER 1min ON, 2min. OFF, 10 cycles Ambient temperature 70°C	600mW
3. MAX. NOISE POWER (PHC continuous) 500h Ambient temperature 70°C	500mW

(FREQUENCY RANGE IN TELECOM APPLICATION: 300Hz – 3,4kHz)



4.3. Measurement setup

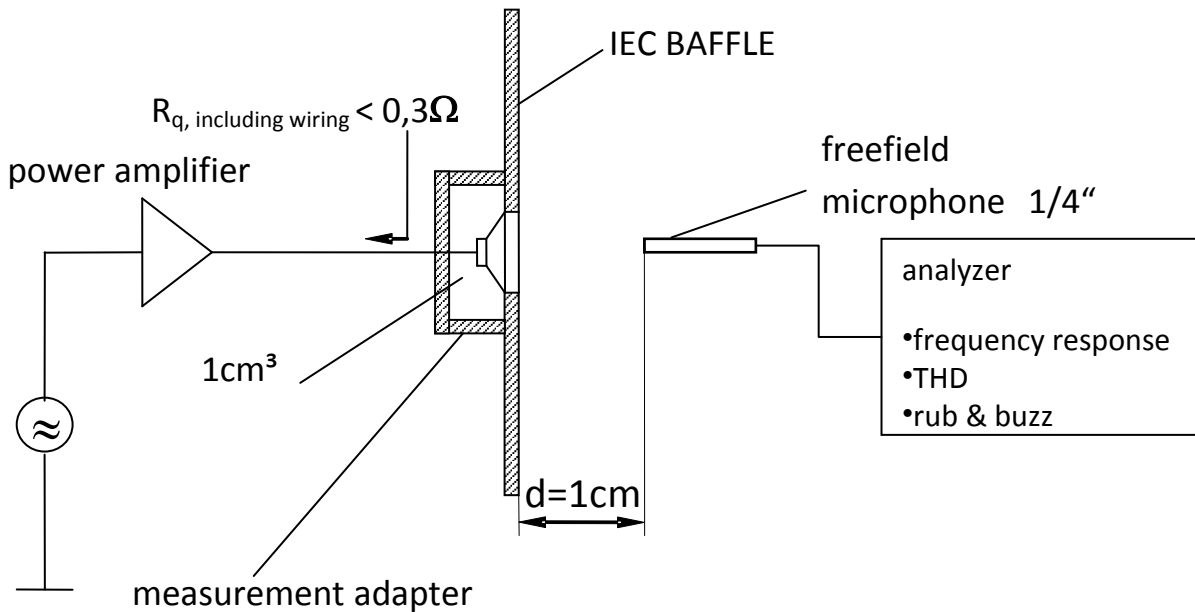

4.4. Measured Parameters

4.4.1. Sensitivity

SPL is expressed in dB rel $20\mu\text{Pa}$, computed according to IEC 268-5. Measurement set up and parameters according chapter 5.3 This test is performed for 100% of products in the production line.

4.4.2. Frequency response

Frequency response is measured according test set up in chapter 5.3 , data sheet and checked against the tolerance window defined in chapter 5.1. This Test is performed for 100% of products in the production line.

4.4.3. Total harmonic distortion (THD)

Is measured according IEC 268-5 (2nd to 5th harmonics) and test set up in chapter 5.3. This test is performed for 100% of products in the production line.

4.4.4. Rub& Buzz

Rub & Buzz will be measured in the Inline-measuring device with a sinusoidal sweep. Rub & Buzz is defined as the maximum level of no harmonic energy, expressed as signal to non-harmonic content ratio, in a certain frequency-range. Signal and evaluation criteria are according to chapter 5. This test is performed for 100% of products in the production line.

2403 260 00089

4.5. Measurement adapter 1 cm³

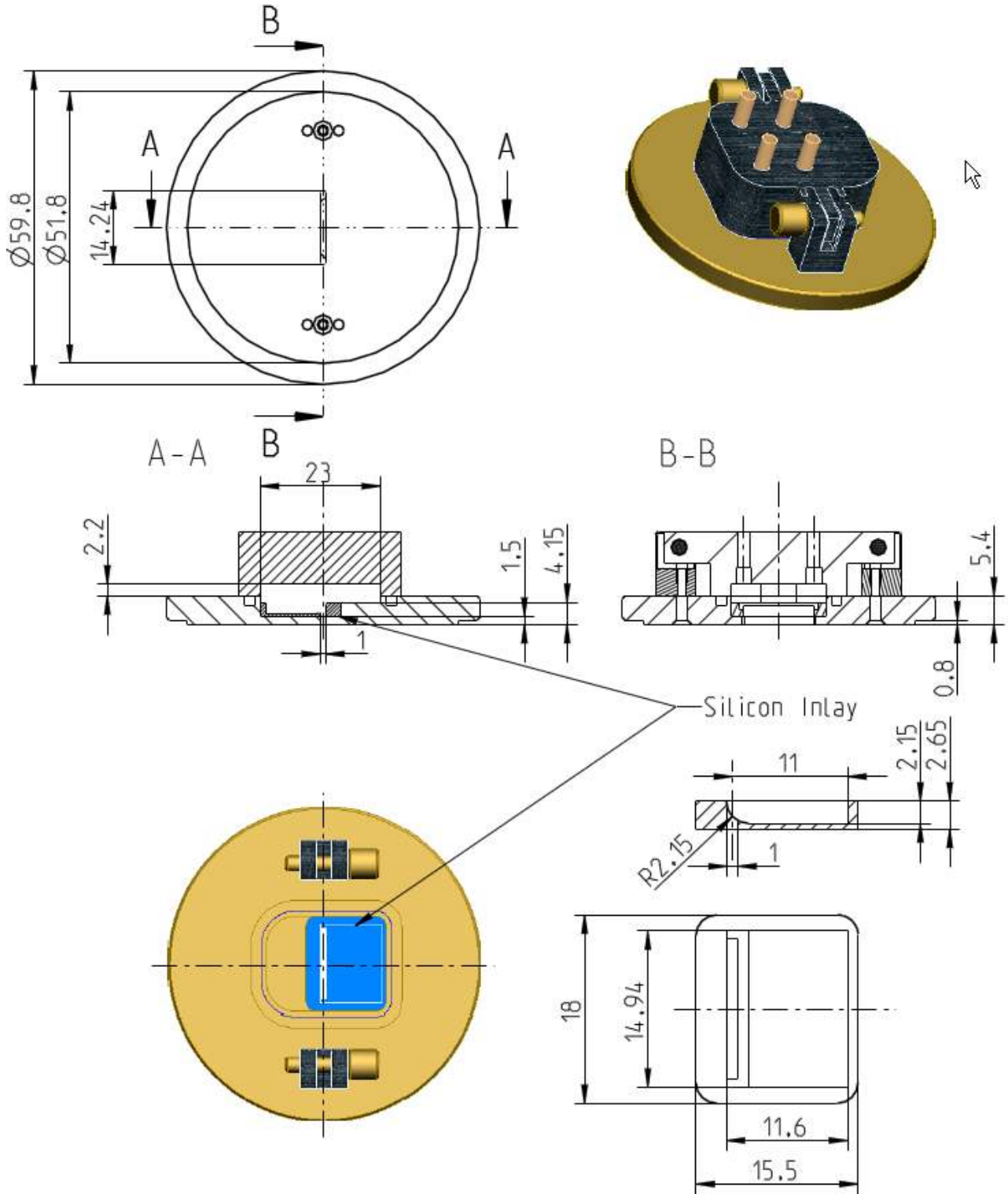

2403 260 00089

5. Environmental Conditions

5.1. Storage

The transducer fulfils the specified data after treatment according to the conditions of

ETS 300 019-2-1 Specification of environmental test: Storage
Test spec. T 1.2: Weather protected, not temperature controlled storage locations.

5.2. Transportation

The transducer fulfils the specified data after treatment according to the conditions of

ETS 300 019-2-2 Specification of environmental test: Transportation
Test Spec. T 2.3: Public Transportation

5.3. Functionality

The transducer fulfils the specified data after treatment according to the conditions of

ETS 300 019-2-5 Specification of environmental test: Ground vehicle installations
Test spec. T 5.1: Protected installation

ETS 300 019-2-7 Specification of environmental test: Portable and non-stationary use
Test spec. T 7.3E: Partly weather protected and non-weather protected locations.

6. Environmental tests

6.1. Qualification tests

According to our milestone plan (Product Creation Process), a complete qualification test will be done at design validation of products manufactured under serial conditions.

1x per year and product family a requalification takes place. The qualification process covers all tests described under 7.5 and a complete inspection.

6.2. Reliability tests

1x per month and product family samples are taken and submitted to tests described under 7.5.2

6.3. Sample Size, Sequence

Unless otherwise stated 20 arbitrary new samples will be used to perform each test for both, qualification and requalification test as described under 7.1 and 7.2.

6.4. Period of Shelf-Life

The period of shelf-life is 2 years.

6.5. Testing Procedures

6.5.1. Storage Tests

6.5.1.1. Low Temperature Storage Test

Parameter	Test Method and Conditions	Duration	Evaluation Standard
Low Temperature Storage (Ref. EN 60068-2-1)	-40°C rel. humidity not controlled	168h	Measurements after 2 hours recovery time. All samples fully operable. All acoustical parameters according specification with tolerances increased by 50 %.

6.5.1.2. High Temperature Storage Test

Parameter	Test Method and Conditions	Duration	Evaluation Standard
Dry Heat Storage (Ref. EN 60068-2-2)	+85°C rel. humidity not controlled	168h	Measurements after 2 hours recovery time. All samples fully operable. All acoustical parameters according specification with tolerances increased by 50 %.

2403 260 00089

6.5.1.3. Temperature Cycle Test

Parameter	Test Method and Conditions	Duration	Evaluation Standard
Change of Temperature (Ref. EN 60068-2-14)	-40°C/+85°C Transition time <3 min. See Figure 7-1 below	5 cycles >2h for each temperature	Measurements after 2 hours recovery time. All samples fully operable. All acoustical parameters according specification with tolerances increased by 50 %.

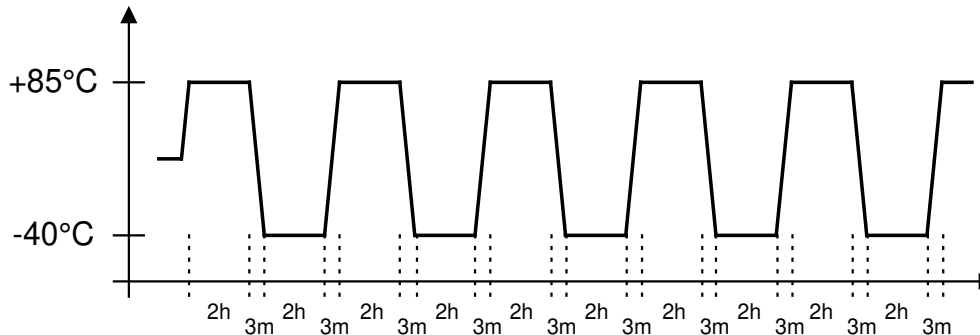

Figure 7-1: Temperature Cycle Test

6.5.1.4. Temperature / Humidity Cycle Test

Parameter	Test Method and Conditions	Duration	Evaluation Standard
Damp heat, cyclic (Ref. IEC 60068-2-30)	+25°C/+55°C 90% to 95% RH. Temp. change time <3h See Figure 7-2 below <u>Caution:</u> no condensed water on products!	6 cycles. 12h at each temperature	Measurements after 2 hours recovery time. All samples fully operable. All acoustical parameters according specification with tolerances increased by 50 %.

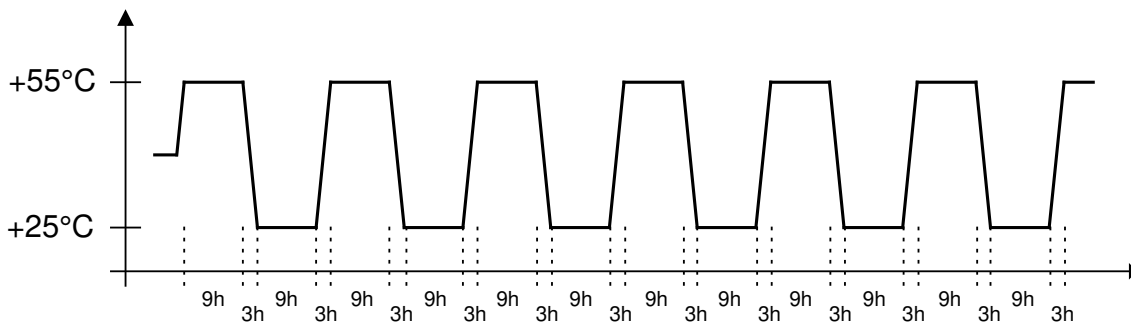

Figure 7-2: Temperature / Relative Humidity Cycle Test

6.5.2. Operating Tests

6.5.2.1. Cold Operation Test

Parameter	Test Method and Conditions	Duration	Evaluation Standard
Cold Operation Test (Ref. EN 60068-2-1)	-20°C rel. humidity not controlled signal acc. Chapter 5.2.	72h	Measurements after 2 hours recovery time. All samples fully operable. THD may be increased after test. All other acoustical parameters according specification with tolerances increased by 50 %.

6.5.2.2. Dry Heat Operation Test

Parameter	Test Method and Conditions	Duration	Evaluation Standard
Dry Heat Operation (Ref. EN 60068-2-2)	+70°C rel. humidity not controlled signal acc. Chapter 5.2	500h	Measurements after 2 hours recovery time. All samples fully operable. The allowable change in sensitivity shall not be greater than 3 dB. All other acoustical parameters according specification with tolerances increased by 50 %.

6.5.3. Salt Mist Test

Parameter	Test Method and Conditions	Duration	Evaluation Standard
Salt Mist (Ref. IEC60068-2-52, Kb / Severity 2)	The part must be subjected to 2 hours spray of 5% NaCl salt mist, at 35°C then be left at 40°C and 95% RH for 22h.	3 cycles	The samples shall be washed after the test with distilled water and dried at T < 50°C. Component may have reduced performance, but must still function properly. The allowable sensitivity difference shall not be greater than ±3dB from initial sensitivity.

2403 260 00089

6.5.4. Shock Resistance Test (Free Fall Test) - protected product

Parameter	Test Method and Conditions	Conditions / Sample size	Evaluation Standard
Mechanical shock (Ref. IEC60068-2-32 Ed), Procedure 1	Speaker in drop test box or representative mechanics from a height of 1.5m onto concrete floor.	30 units Two drops on each side (2x6) One drop on each edge (1x12) Two drops on each corner (2x8) (40 drops in total)	Component may have reduced performance, but must still function properly. The allowable sensitivity difference shall not be greater than ± 3 dB from initial sensitivity.

6.5.5. Impact Durability Test (Tumble Test) – protected product

Parameter	Test Method and Conditions	Conditions / Sample size	Evaluation Standard
Impact durability (in a Tumble Tester) (Ref. IEC60068-2-32 Ed) (SPR a7.1.1)	Speaker <i>in drop test box</i> or representative mechanics. Random drops on steel base.	30 units 180 drops, 1m DUT power off	Component may have reduced performance, but must still function properly. The allowable sensitivity difference shall not be greater than ± 3 dB from initial sensitivity.

6.5.6. Resistance to Electrostatic Discharge

Parameter	Test Method and Conditions	Conditions / Sample size	Evaluation Standard
Resistance to ESD IEC61000-4-2 Level 4 (SPR c 2.5.1)	One pole is grounded and the ESD pulse is applied to the other pole. The speaker must be stressed first with one polarisation and then with the other polarisation. DUT must be discharged between each ESD exposure. Level 4: contact +/- 8kV, air +/- 15kV	10 exposures on each polarity / 5 units DUT Power off	All samples fully operable. All acoustical parameters according specification with tolerances increased by 50%.

2403 260 00089

7. Related Documents

IEC 268-5	Sound System equipment Part 5: Loudspeaker
IEC 68-2	Environmental testing
EN 60068-2	Environmental testing
ISO 2859 - 1	Sampling procedures for inspection by attributes Part 1: Sampling plans indexed by acceptable quality level (AQL) for lot-by-lot inspection
ISO 3951	Sampling procedures and charts for inspection by variables for percent defectives.
ETS 300 019-2-1	Specification of environmental test: Storage Test spec. T 1.2: Weather protected, not temperature controlled storage locations
ETS 300 019-2-2	Specification of environmental test: Transportation Test spec. T 2.3: Public Transportation
ETS 300 019-2-5	Specification of environmental test: Ground vehicle installations Test spec. T 5.1: Protected installation
ETS 300 019-2-7	Specification of environmental test: Portable and non-stationary use Test spec. T 7.3E: Partly weather protected and non-weather protected locations
APN0xx	Side porting integration guidelines for SPEAKER-1115-SC-NAUTILUS 180

2403 260 00089

8. Change History

Status	Version	Date	ECR	Comment / Changes	Initials of owner
Obsolete	A	10.10.11	3366	First Release	SG/SA/CP/AT/RB/CP
Obsolete	B	08.03.12	3559	Change Printing/update test matrix	SA/CP
Release	C	02.07.12	3715	-Change pot retention force from 200 N to 150 N -change tolerance of contact height from +/-0.05 mm to +/-0.1 mm	MS/SA

9. Disclaimer

Stresses above the Absolute Maximum Ratings may cause permanent damage to the device. These are stress ratings only. The device may not function when operated at these or any other conditions beyond those indicated under “Electrical and Acoustical Specifications”. Exposure beyond those indicated under “Electrical and Acoustical Specifications” for extended periods may affect device reliability.

This product is not qualified for use in automotive applications

Frequency range for Telekom use

