

THIS DRAWING IS UNPUBLISHED
 © COPYRIGHT 2020 BY TE CONNECTIVITY
 ALL RIGHTS RESERVED.

LOC	DIST	REVISIONS			
P	LTR	DESCRIPTION	DATE	DWN	APVD
	F	REVISED PER ECO-15-007761	28MAY2015	RL	DM
	G	REVISED PER PCN E-20-008101	12JUN2020	DM	DM
	G1	REVISED PER PCN-22-157823	12OCT2022	SP	DM

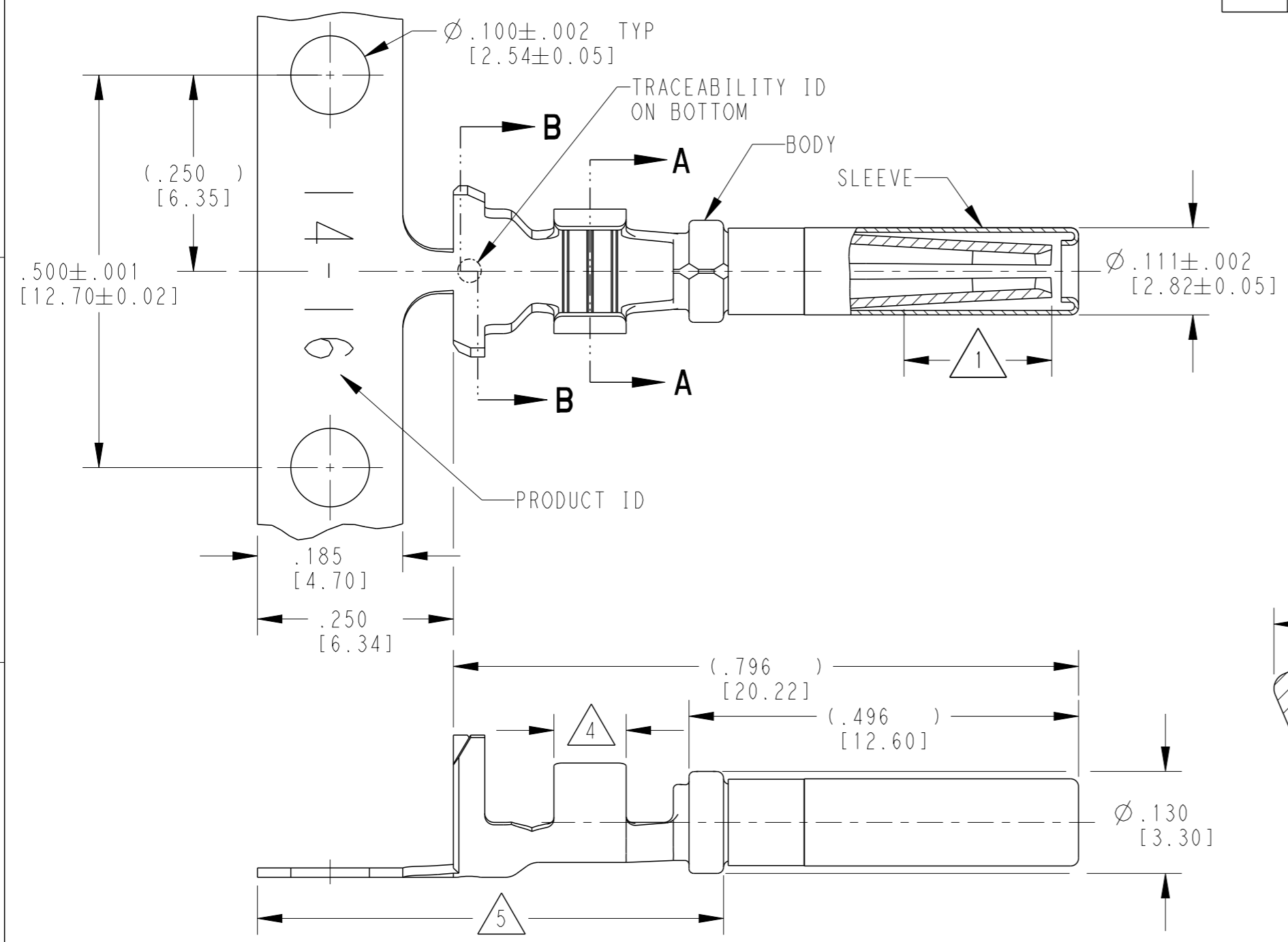

OPTIONAL TRACEABILITY ID LOCATED ON DIAMETER

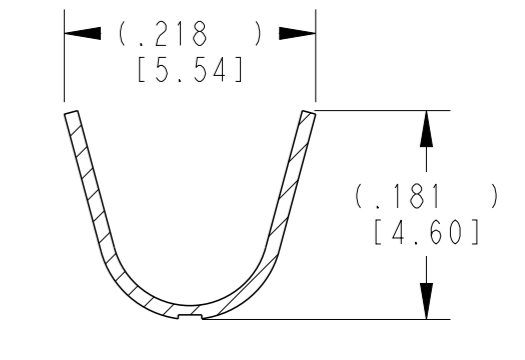
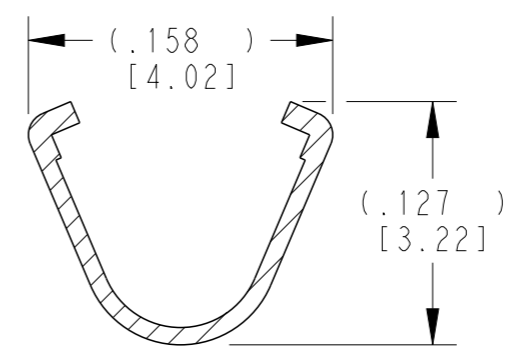
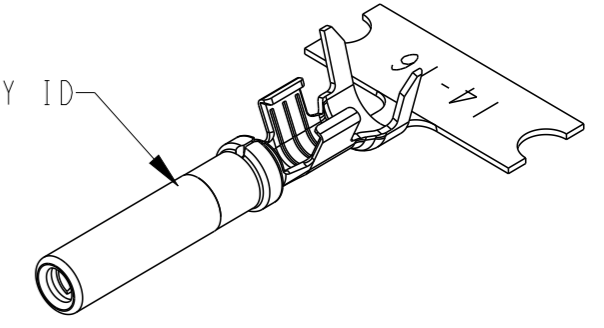

5 TIN PLATING MAY BE IN THIS REGION.

4 TIN PLATED REGION.

3 MATERIAL:
 BODY: .012 [0.30] THICK COPPER ALLOY
 SLEEVE: STAINLESS STEEL

2. WIRE RANGE: 18 AWG TO 14 AWG [0.75-2.0 mm²]
 INSULATION RANGE: Ø.095-.150 [Ø2.41-3.81]

1 GOLD PLATED REGION.

NOTES: UNLESS OTHERWISE SPECIFIED

TE INTERNAL PN	DEUTSCH PN	PLATING
1062-14-0122	1062-14-0122	Ni/Cu overall, Sn/Ni/Cu Wire Barrel
1062-14-0144	1062-14-0144	Selective Au, Ni/Cu overall, Sn/Ni/Cu Wire Barrel
1062-14-0177	1062-14-0177	Sn/Ni/Cu overall

THIS DRAWING IS A CONTROLLED DOCUMENT.		DWN M. BLUM 04NOV1999	TE TE Connectivity	
DIMENSIONS: INCHES [mm]		CHK VLADIMIR TOMSA 04DEC2000		
TOLERANCES UNLESS OTHERWISE SPECIFIED:		APVD R. REED 08DEC2000	NAME SOCKET, STAMPED AND FORMED SIZE 16 14-18AWG	
0 PLC ±		PRODUCT SPEC 108-151000	SIZE A3	
1 PLC ±		APPLICATION SPEC 114-151000	CAGE CODE 4AFU8	DRAWING NO C=1062-14-01XX
2 PLC ±		WEIGHT 0.44 g	RESTRICTED TO -	
3 PLC ±0.025 [0.64]		Customer Drawing		
4 PLC ±		SCALE 6:1 SHEET 1 OF 1 REV G1		
ANGLES ±				
FINISH SEE TABLE				