

DETAIL "D"

NOTES

- 製品詳細寸法については製品単体図面を参照下さい。
FOR DETAILED DIMENSION, SEE PRODUCT DRAWING.
- 梱包数量：シート 2, 3, 4の表をご確認ください。
NUMBER OF CONNECTORS : SEE CHART ON SHEET 2, 3, 4
- リードテープ長さ LEAD TAPE LENGTH

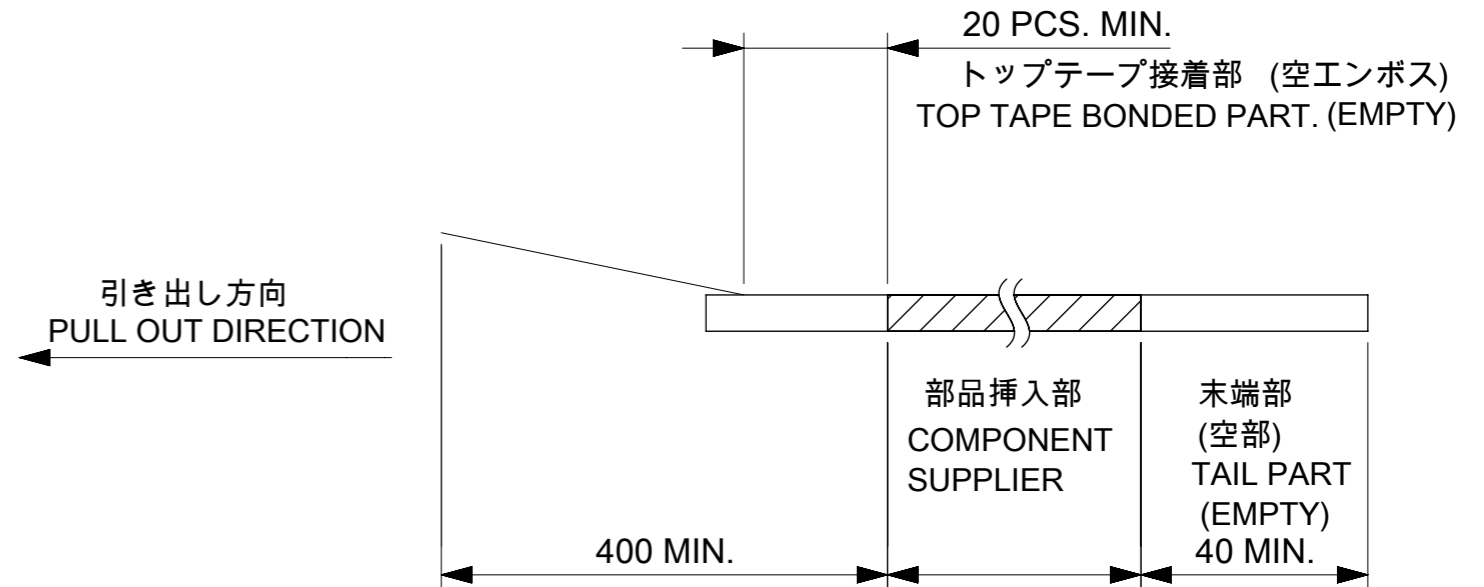

- カバーテープの剥離強度については、IEC-60286-3に準拠
COVER TAPE PEEL FORCE IS DEFINED BY IEC-60286-3.
- 材料 MATERIAL
 キャリアテープ(CARRIER TAPE) : ポリスチレン(POLYSTYRENE)
 トップテープ(TOP TAPE) : PET , OTHER
 リール(REEL) : ポリスチレン(PS) (リサイクル材を含む)
 POLYSTYRENE (PS) (RECYCLE MATERIAL CONTAINED)

THIS DRAWING CONTAINS INFORMATION THAT IS PROPRIETARY TO MOLEX ELECTRONIC TECHNOLOGIES, LLC AND SHOULD NOT BE USED WITHOUT WRITTEN PERMISSION		CURRENT REV DESC: RELEASED		molex			
DIMENSION UNITS	SCALE					0.4 MM PITCH BOARD-TO-BOARD CONNECTOR HIGH RETENTION FORCE (HRF) 7S/7L REC ASSY EMBSTP PKG	
mm	NTS			PRODUCT CUSTOMER DRAWING			
GENERAL TOLERANCES (UNLESS SPECIFIED)		EC NO: 635356		DOCUMENT NUMBER			
ANGULAR TOL	± 3.0 °	DRWN: KYHWANG 2020/03/04		5035480000-SD			
4 PLACES	± 0.03	CHK'D: HSHIMUYAMA 2020/04/13		DOC TYPE DOC PART REVISION			
3 PLACES	± 0.03	APPR: SHOSHIKAWA 2020/04/13		PSD 000 A			
2 PLACES	± 0.05	INITIAL REVISION:					
1 PLACE	± 0.1	DRWN: KYHWANG 2020/03/04					
0 PLACES	± 0.2	APPR: SHOSHIKAWA 2020/04/13					
DRAFT WHERE APPLICABLE MUST REMAIN WITHIN DIMENSIONS		THIRD ANGLE PROJECTION	DRAWING	SERIES	MATERIAL NUMBER	CUSTOMER	SHEET NUMBER
			A3-SIZE	503548	SEE CHART	GENERAL	1 OF 4

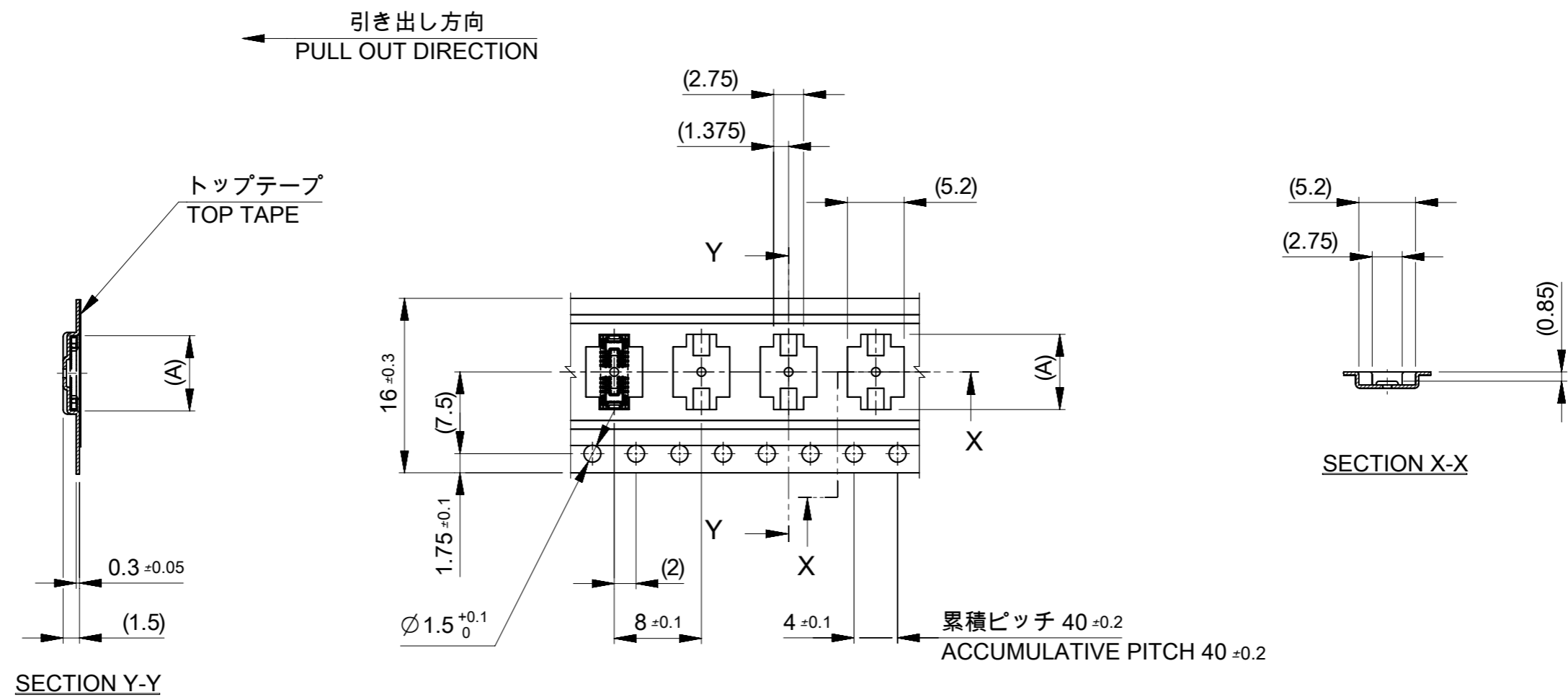

16 mm 幅キャリアテープ
16 mm WIDTH CARRIER TAPE

16	7000	21.4	17.4	6.5	5035481822	18
				6.1	5035481622	16
				5.7	5035481422	14
				5.3	5035481222	12
				4.9	5035481022	10
				4.1	5035480622	6
キャリアテープ幅 CARRIER TAPE WIDTH	NUMBER OF CONNECTORS [PCS/REEL]	C	B	(A)	ORDER No.	CKT.

THIS DRAWING CONTAINS INFORMATION THAT IS PROPRIETARY TO MOLEX ELECTRONIC TECHNOLOGIES, LLC AND SHOULD NOT BE USED WITHOUT WRITTEN PERMISSION

DIMENSION UNITS mm	SCALE NTS	CURRENT REV DESC: RELEASED				
GENERAL TOLERANCES (UNLESS SPECIFIED)		<p style="text-align: center;">molex</p> <p style="text-align: center;">0.4 MM PITCH BOARD-TO-BOARD CONNECTOR HIGH RETENTION FORCE (HRF) 7S/7L REC ASSY EMBSTP PKG</p> <p style="text-align: center;">PRODUCT CUSTOMER DRAWING</p>				
ANGULAR TOL	± 3.0 °					
4 PLACES	± 0.03					
3 PLACES	± 0.03					
2 PLACES	± 0.05					
1 PLACE	± 0.1					
0 PLACES	± 0.2	EC NO: 635356		2020/03/04		
DRAFT WHERE APPLICABLE MUST REMAIN WITHIN DIMENSIONS		THIRD ANGLE PROJECTION		DRAWING A3-SIZE	SERIES 503548	
DOCUMENT STATUS		DOCUMENT NUMBER		DOC TYPE	DOC PART	REVISION
P1	RELEASE DATE 2020/04/13 10:49:30	5035480000-SD		PSD	000	A
SHEET NUMBER 2 OF 4		CUSTOMER GENERAL				

引き出し方向
PULL OUT DIRECTION

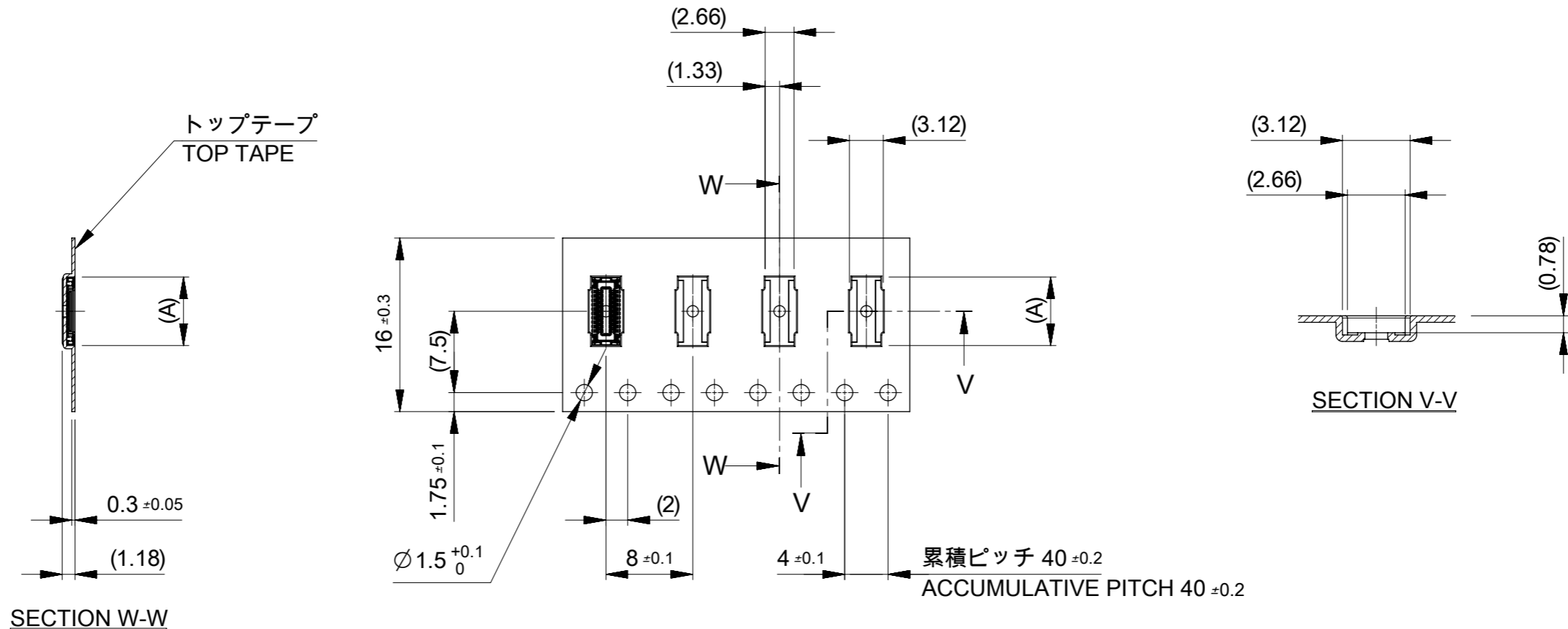

16	9000	21.4	17.4	7.52	5033042642	26
				7.12	5033042442	24
				6.32	5033042042	20
キャリアテープ幅 CARRIER TAPE WIDTH	NUMBER OF CONNECTORS [PCS/REEL]	C	B	(A)	ORDER No.	CKT.

THIS DRAWING CONTAINS INFORMATION THAT IS PROPRIETARY TO MOLEX ELECTRONIC TECHNOLOGIES, LLC AND SHOULD NOT BE USED WITHOUT WRITTEN PERMISSION		CURRENT REV DESC: RELEASED		molex		
DIMENSION UNITS mm	SCALE NTS					
GENERAL TOLERANCES (UNLESS SPECIFIED)				PRODUCT CUSTOMER DRAWING		
ANGULAR TOL	± 3.0 °			DOCUMENT NUMBER		
4 PLACES	± 0.03	EC NO: 635356		5035480000-SD		
3 PLACES	± 0.03	DRWN: KYHWANG 2020/03/04		DOC TYPE		
2 PLACES	± 0.05	CHK'D: HSHIMYOYAMA 2020/04/13		PSD		
1 PLACE	± 0.1	APPR: SHOSHIKAWA 2020/04/13		DOC PART		
0 PLACES	± 0.2	INITIAL REVISION:		000		
DRAFT WHERE APPLICABLE MUST REMAIN WITHIN DIMENSIONS		DRWN: KYHWANG 2020/03/04		REVISION		
THIRD ANGLE PROJECTION		APPR: SHOSHIKAWA 2020/04/13		A		
DRAWING		SERIES		SHEET NUMBER		
A3-SIZE		503548		3 OF 4		
MATERIAL NUMBER		CUSTOMER				
SEE CHART		GENERAL				

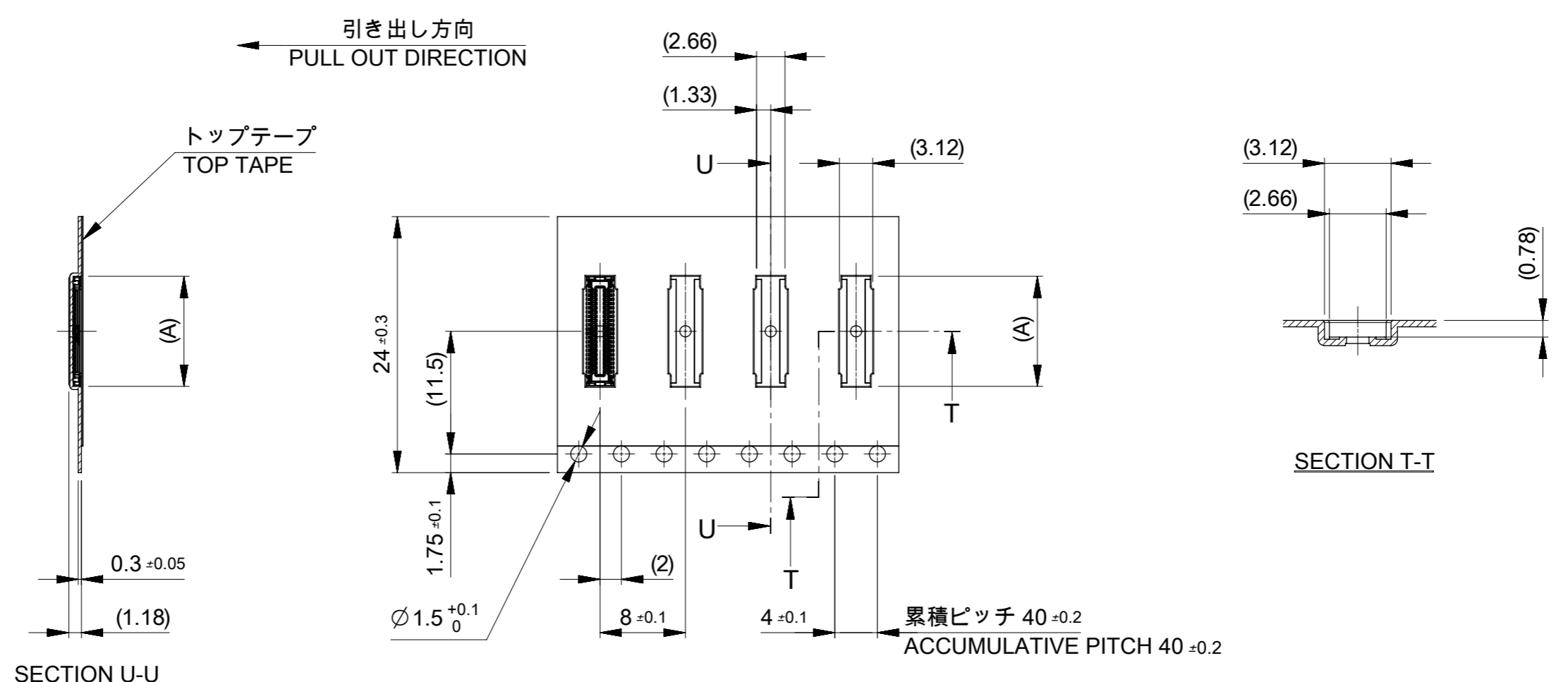

24 mm 幅キャリアテープ
24 mm WIDTH CARRIER TAPE

24	9000	29.4	25.4	14.32	5033046042	60
				12.32	5033045042	50
				11.12	5033044442	44
				10.72	5033044242	42
				10.32	5033044042	40
				8.32	5033043042	30
キャリアテープ幅 CARRIER TAPE WIDTH	NUMBER OF CONNECTORS [PCS/REEL]	C	B	(A)	ORDER No.	CKT.

THIS DRAWING CONTAINS INFORMATION THAT IS PROPRIETARY TO MOLEX ELECTRONIC TECHNOLOGIES, LLC AND SHOULD NOT BE USED WITHOUT WRITTEN PERMISSION

DIMENSION UNITS: mm SCALE: NTS

GENERAL TOLERANCES (UNLESS SPECIFIED):

ANGULAR TOL	± 3.0 °
4 PLACES	± 0.03
3 PLACES	± 0.03
2 PLACES	± 0.05
1 PLACE	± 0.1
0 PLACES	± 0.2

EC NO: 635356
DRWN: KYHWANG 2020/03/04
CHK'D: HSHIMOYAMA 2020/04/13
APPR: SHOSHIKAWA 2020/04/13

INITIAL REVISION:
DRWN: KYHWANG 2020/03/04
APPR: SHOSHIKAWA 2020/04/13

THIRD ANGLE PROJECTION

DRAWING: A3-SIZE SERIES: 503548 MATERIAL NUMBER: SEE CHART CUSTOMER: GENERAL SHEET NUMBER: 4 OF 4

molex

0.4 MM PITCH BOARD-TO-BOARD CONNECTOR
HIGH RETENTION FORCE (HRF) 7S/7L
REC ASSY EMBSTP PKG

PRODUCT CUSTOMER DRAWING

DOCUMENT NUMBER: 5035480000-SD DOC TYPE: PSD DOC PART: 000 REVISION: A

503548-**22 6 ~ 18 CKT.

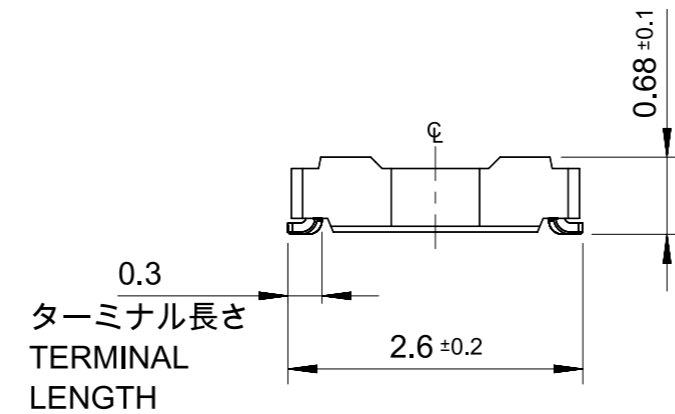
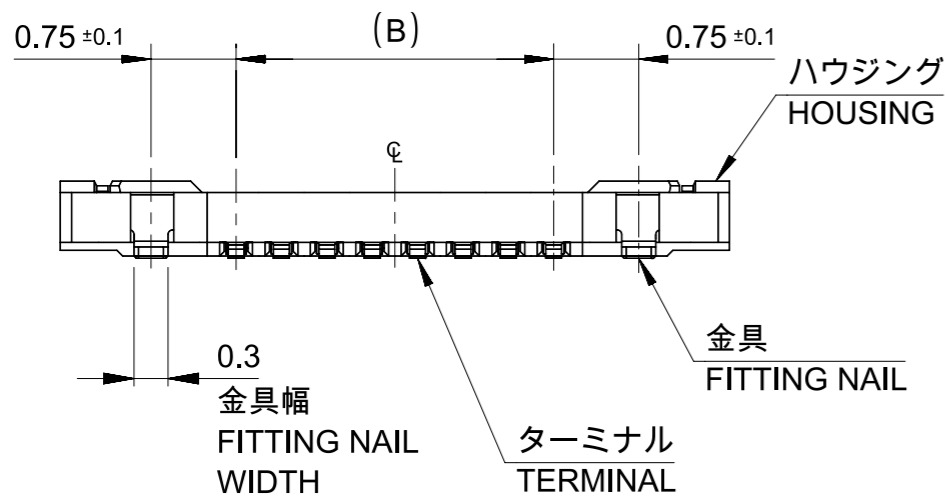
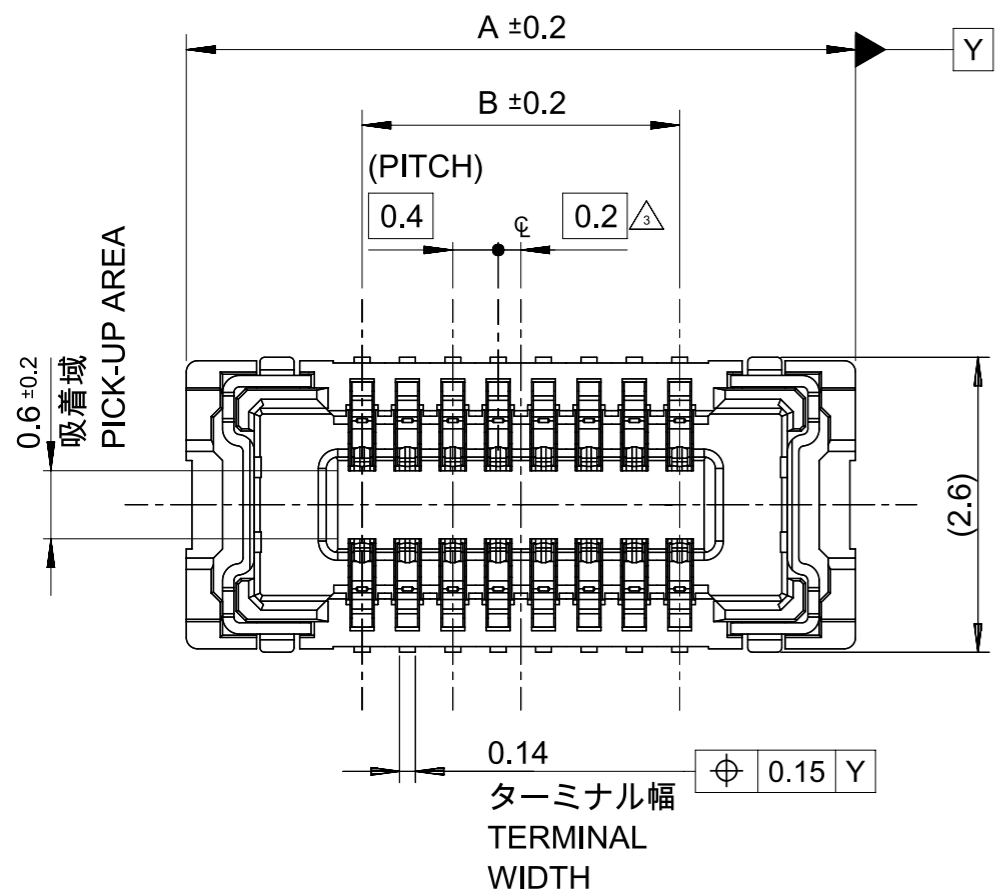

注記 NOTES

1. 使用材料 MATERIAL

ハウジング : 液晶ポリマー(LCP) UL94V-0 (黒)
 HOUSING : LIQUID CRYSTAL POLYMER, UL94V-0 (COLOR : BLACK)
 ターミナル : 銅合金
 TERMINAL : COPPER ALLOY
 金具 : 銅合金
 FITTING NAIL : COPPER ALLOY

2. メッキ仕様 PLATING

ターミナル TERMINAL
 コンタクト部 : 金メッキ (0.1µm以上)
 CONTACT AREA : GOLD (0.1µm MINIMUM)
 テール部 : 金メッキ
 SOLDER TAIL AREA : GOLD
 下地メッキ : ニッケルメッキ (1.0µm以上)
 UNDER PLATING : NICKEL (1.0µm MINIMUM)

※ コンタクト部とテール部の基板接触面には金メッキを施しています。それ以外の個所には金メッキもしくはニッケルメッキが露出し、外観上、色調が異なる場合がありますが、性能には影響ありません。但し、コンタクト部とテール部の間にはニッケルメッキで金メッキを分断している個所があります。
 THE CONTACT PART AND SOLDER TAIL SURFACE OF TERMINAL WHICH CONTACTS PAD OF PWB ARE PLATED WITH GOLD. THE OTHER SURFACES ARE PLATED WITH GOLD OR NICKEL UNDERPLATING EXCEPT CUTOFF. THE GOLD PLATING IS DIVIDED INTO TWO SECTIONS BY NICKEL, WHICH ARE CONTACT AND SOLDER TAIL PARTS. IT IS NO PROBLEM IN THE PERFORMANCE ALTHOUGH THOSE MAY SEEM DIFFERENT COLOR TONE.

金具 FITTING NAIL

金メッキ (テール部のみ)
 GOLD (ONLY TAIL PART)
 下地メッキ : ニッケルメッキ
 UNDER PLATING : NICKEL

△ (全極数/2)=偶数の場合に適用。
 APPLY FOR (CIRCUIT/2)=EVEN.

4. 嵌合相手 : 503552シリーズ
MATE WITH : 503552 SERIES.
5. テール平坦度は、0.08以下、テール及び金具の平坦度は、0.1以下。
TAIL COPLANARITY TO BE 0.08 MAXIMUM.
TAIL AND FITTING NAIL COPLANARITY TO BE 0.1 MAXIMUM.
6. 本0.4 mmピッチBOARD-TO-BOARD CONNECTOR HRF 7S/7Lシリーズは503304 / 503308と503548 / 503552シリーズを統合した製品群です
THIS PRODUCT FAMILY, 0.4 MM PITCH BOARD-TO-BOARD CONNECTOR HRF 7S/7L, IS WHAT 503304 AND 503548 SERIES WERE UNIFIED.

11.6	14.2	5033046042	60
9.6	12.2	5042	50
8.4	11.0	4442	44
8.0	10.6	4242	42
7.6	10.2	4042	40
5.6	8.2	3042	30
4.8	7.4	2642	26
4.4	7.0	2442	24
3.6	6.2	5033042042	20
3.2	6.3	5035481822	18
2.8	5.9	1622	16
2.4	5.5	1422	14
2.0	5.1	1222	12
1.6	4.7	1022	10
0.8	3.9	5035480622	6
B	A	EMBOSSED PACKAGE	極数
		オーダー番号 ORDER No.	CIRCUITS

THIS DRAWING CONTAINS INFORMATION THAT IS PROPRIETARY TO MOLEX ELECTRONIC TECHNOLOGIES, LLC AND SHOULD NOT BE USED WITHOUT WRITTEN PERMISSION

DIMENSION UNITS	SCALE	CURRENT REV DESC: RELEASED		molex		
mm	NTS					
GENERAL TOLERANCES (UNLESS SPECIFIED)				0.4 MM PITCH BOARD-TO-BOARD CONNECTOR HIGH RETENTION FORCE (HRF) 7S/7L REC ASSY		
ANGULAR TOL	± 3.0 °			PRODUCT CUSTOMER DRAWING		
4 PLACES	± 0.03	EC NO: 635356		DOCUMENT NUMBER		
3 PLACES	± 0.03	DRWN: KYHWANG	2020/03/04	DOC TYPE DOC PART REVISION		
2 PLACES	± 0.05	CHK'D: HSHIMUYAMA	2020/04/13	5035481000-SD		
1 PLACE	± 0.1	APPR: SHOSHIKAWA	2020/04/13	PSD	000	A
0 PLACES	± 0.2	INITIAL REVISION:		SHEET NUMBER		
DRAFT WHERE APPLICABLE MUST REMAIN WITHIN DIMENSIONS		DRWN: KYHWANG	2020/03/04	SEE CHART	GENERAL	1 OF 3
THIRD ANGLE PROJECTION		APPR: SHOSHIKAWA	2020/04/13			
DRAWING		SERIES	MATERIAL NUMBER	CUSTOMER		
A3-SIZE		503548	SEE CHART	GENERAL		

503304-**42 20 ~ 60 CKT.

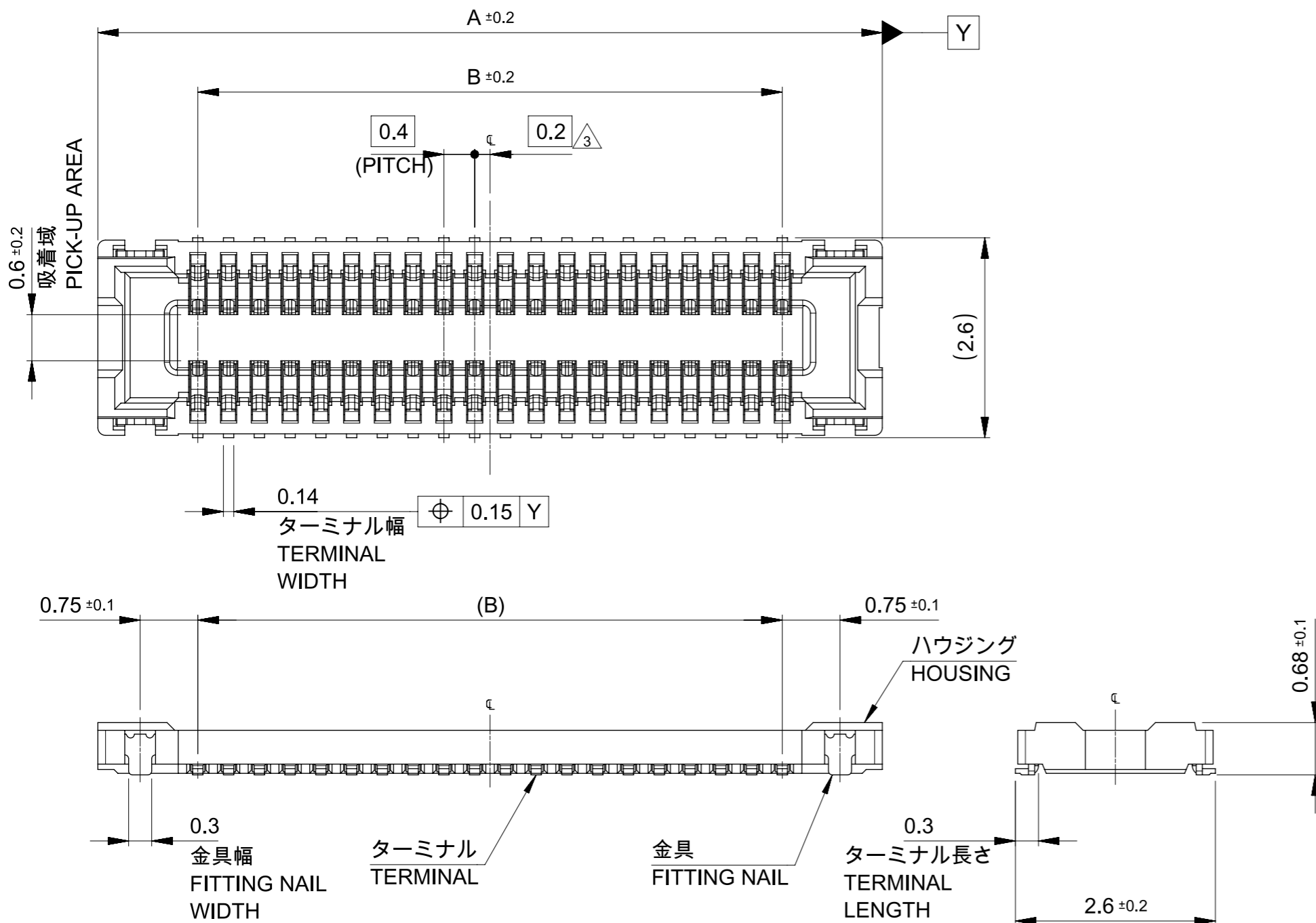

注記 NOTES

- 使用材料 MATERIAL
 ハウジング : 液晶ポリマー(LCP) UL94V-0 (黒)
 HOUSING : LIQUID CRYSTAL POLYMER, UL94V-0 (COLOR : BLACK)
 ターミナル : 銅合金
 TERMINAL : COPPER ALLOY
 金具 : 銅合金
 FITTING NAIL : COPPER ALLOY
 - メッキ仕様 PLATING
 ターミナル TERMINAL
 コンタクト部 : 金メッキ (0.1µm以上)
 CONTACT AREA : GOLD (0.1µm MINIMUM)
 テール部 : 金メッキ
 SOLDER TAIL AREA : GOLD
 下地メッキ : ニッケルメッキ (1.0µm以上)
 UNDER PLATING : NICKEL (1.0µm MINIMUM)
 ※ コンタクト部とテール部の基板接触面には金メッキを施しています。
 それ以外の個所には金メッキもしくはニッケルメッキが露出し、
 外観上、色調が異なる場合がありますが、性能には影響ありません。
 但し、コンタクト部とテール部の間にはニッケルメッキで
 金メッキを分断している個所があります。
 THE CONTACT PART AND SOLDER TAIL SURFACE OF TERMINAL
 WHICH CONTACTS PAD OF PWB ARE PLATED WITH GOLD.
 THE OTHER SURFACES ARE PLATED WITH GOLD OR NICKEL
 UNDERPLATING EXCEPT CUTOFF.
 THE GOLD PLATING IS DIVIDED INTO TWO SECTIONS BY NICKEL,
 WHICH ARE CONTACT AND SOLDER TAIL PARTS.
 IT IS NO PROBLEM IN THE PERFORMANCE ALTHOUGH THOSE
 MAY SEEM DIFFERENT COLOR TONE.
- 金具 FITTING NAIL
 錫メッキ
 TIN PLATING
 下地メッキ : ニッケルメッキ
 UNDER PLATING : NICKEL
- △₃ (全極数/2)=偶数の場合に適用。
 APPLY FOR (CIRCUIT/2)=EVEN.
- 嵌合相手 : 503308シリーズ
 MATE WITH : 503308 SERIES.
 - テール平坦度は、0.08以下、テール及び金具の平坦度は、0.1以下。
 TAIL COPLANARITY TO BE 0.08 MAXIMUM.
 TAIL AND FITTING NAIL COPLANARITY TO BE 0.1 MAXIMUM.
 - 本0.4 mm ピッチ BOARD-TO-BOARD CONNECTOR HRF 7S/7L
 シリーズは503304 / 503308と503548 / 503552シリーズを統合した製品群です
 THIS PRODUCT FAMILY, 0.4 MM PITCH BOARD-TO-BOARD CONNECTOR
 HRF 7S/7L, IS WHAT 503304 AND 503548 SERIES WERE UNIFIED.

THIS DRAWING CONTAINS INFORMATION THAT IS PROPRIETARY TO MOLEX ELECTRONIC TECHNOLOGIES, LLC AND SHOULD NOT BE USED WITHOUT WRITTEN PERMISSION		CURRENT REV DESC: RELEASED		molex	
DIMENSION UNITS	SCALE				
mm	NTS				
GENERAL TOLERANCES (UNLESS SPECIFIED)					
ANGULAR TOL	± 3.0 °				
4 PLACES	± 0.03	EC NO: 635356			
3 PLACES	± 0.03	DRWN: KYHWANG	2020/03/04		
2 PLACES	± 0.05	CHK'D: HSHIMOHAMA	2020/04/13		
1 PLACE	± 0.1	APPR: SHOSHIKAWA	2020/04/13		
0 PLACES	± 0.2	INITIAL REVISION:		DOCUMENT NUMBER	
DRAFT WHERE APPLICABLE MUST REMAIN WITHIN DIMENSIONS		THIRD ANGLE PROJECTION		5035481000-SD	
		DRAWING		DOC TYPE	DOC PART
		A3-SIZE		PSD	000
		SERIES		REVISION	A
		503548			
		MATERIAL NUMBER		SHEET NUMBER	
		SEE CHART		2 OF 3	
		CUSTOMER			
		GENERAL			

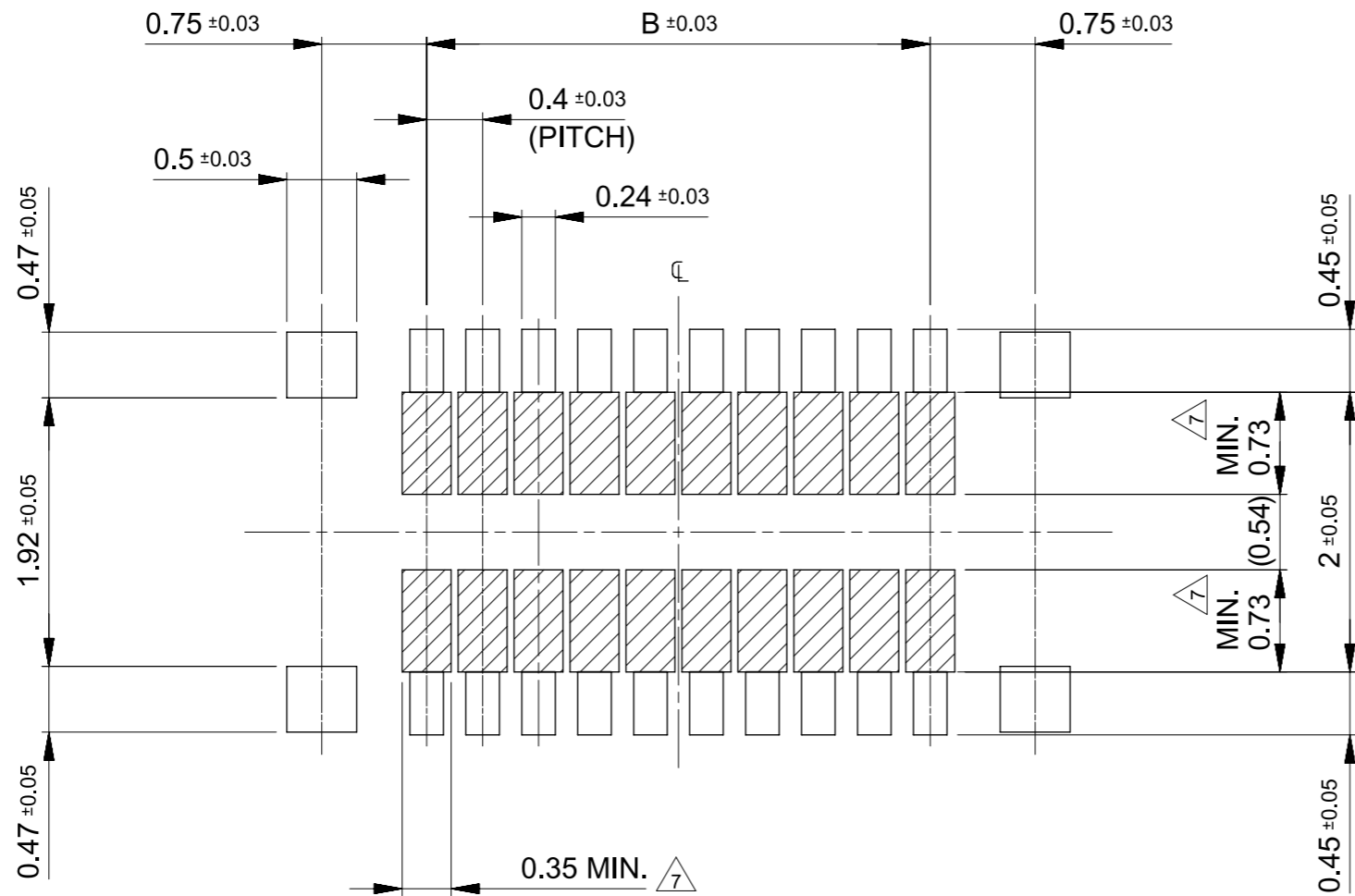

推奨基板レイアウト
RECOMMENDED P.W. BOARD PATTERN LAYOUT

△₇ パターン引き回し、および半田禁止エリア
 (当該箇所においては、これと接触する回路以外の配線を禁止する。
 また、接する回路を配線する場合はレジストを施し、
 この部分に半田は無い事)
 PROHIBITED AREA OF PATTERN WIRING AND SOLDER.
 (IT IS NOT ALLOWED FOR EACH THE AREA TO BE SOLDERED AND
 CONTACT THE OTHER WIRINGS WITHOUT ITSELF ONE.
 IF THEY CONTACTED, RESIST TREATMENT SHOULD BE REQUIRED
 ON IT IN ORDER NOT TO CONTACT EACH OTHER.)

参考メタルマスク開口率 : 100%
 REFERENCE SCREEN OPEN RATIO : 100%

参考メタルマスク厚さ
 REFERENCE SCREEN THICKNESS
 503548-**22 : t=0.08 mm
 503304-**42 : t=0.1 mm

THIS DRAWING CONTAINS INFORMATION THAT IS PROPRIETARY TO MOLEX ELECTRONIC TECHNOLOGIES, LLC AND SHOULD NOT BE USED WITHOUT WRITTEN PERMISSION									
DIMENSION UNITS	SCALE	CURRENT REV DESC: RELEASED							
mm	NTS								
GENERAL TOLERANCES (UNLESS SPECIFIED)					0.4 MM PITCH BOARD-TO-BOARD CONNECTOR HIGH RETENTION FORCE (HRF) 7S/7L REC ASSY				
ANGULAR TOL	± 3.0 °				PRODUCT CUSTOMER DRAWING				
4 PLACES	± 0.03	EC NO: 635356			DOCUMENT NUMBER				
3 PLACES	± 0.03	DRWN: KYHWANG	2020/03/04		5035481000-SD				
2 PLACES	± 0.05	CHK'D: HSHIMUYAMA	2020/04/13		DOC TYPE	DOC PART	REVISION		
1 PLACE	± 0.1	APPR: SHOSHIKAWA	2020/04/13		PSD	000	A		
0 PLACES	± 0.2	INITIAL REVISION:							
DRAFT WHERE APPLICABLE MUST REMAIN WITHIN DIMENSIONS		DRWN: KYHWANG APPR: SHOSHIKAWA			2020/03/04				
THIRD ANGLE PROJECTION		DRAWING	SERIES	MATERIAL NUMBER	CUSTOMER		SHEET NUMBER		
		A3-SIZE	503548	SEE CHART	GENERAL		3 OF 3		