

**1.0 SCOPE**

**1.1 Scope.** This specification covers the detail requirements for a low voltage, micropower dual operational amplifier.

It is highly recommended that this datasheet be used as a baseline for new military or aerospace specification control drawings.

**1.2 Part Number.** The complete part numbers per Table 1 of this specification follow:

<u>Device</u>	<u>Part Number</u>	<u>Package</u>
A	OP-290AZ/883	Z
A	OP-290ARC/883	RC

**1.2.3 Case Outline.** The case outline is designated as follows:

<u>Letter</u>	<u>Case Outline</u> (Lead Finish per MIL-M-38510)
Z	8-lead ceramic dual-in-line package (CERDIP)
RC	20-contact hermetic leadless chip carrier (LCC)

**1.3 Absolute Maximum Ratings.** ( $T_A = +25^\circ\text{C}$ , unless otherwise noted)

Supply Voltage.....	$\pm 18\text{V}$
Input Voltage.....	$[(V^-)-20\text{V}]$ to $[(V^+) + 20\text{V}]$
Differential Input Voltage.....	$[(V^-)-20\text{V}]$ to $[(V^+) + 20\text{V}]$
Output Short-Circuit Duration.....	Continuous
Storage Temperature Range.....	$-65^\circ\text{C}$ to $+150^\circ\text{C}$
Lead Temperature Range (Soldering, 60 sec).....	$300^\circ\text{C}$
Maximum Junction Temperature ( $T_J$ ).....	$-65^\circ\text{C}$ to $150^\circ\text{C}$
Operating Temperature Range.....	$-55^\circ\text{C}$ to $+125^\circ\text{C}$

**1.5 Thermal Characteristics:**

Thermal Resistance, CERDIP (Z) package:

$$\begin{aligned} \text{Junction-to-Case } (\theta_{JC}) &= 26^\circ\text{C/W MAX} \\ \text{Junction-to-Ambient } (\theta_{JA}) &= 119^\circ\text{C/W MAX} \end{aligned}$$

Thermal Resistance, leadless chip carrier (RC) package:

$$\begin{aligned} \text{Junction-to-Case } (\theta_{JC}) &= 30^\circ\text{C/W MAX} \\ \text{Junction-to-Ambient } (\theta_{JA}) &= 120^\circ\text{C/W MAX} \end{aligned}$$

# OP-290

**TABLE 1**

$V_S = \pm 1.5V$  and  $\pm 15V$ ;  $R_S = 50\Omega$ ;  $T_A = +25^\circ C$ ; unless otherwise specified.

Characteristics	Symbol	Special Conditions	OP-290/883 LIMITS A		Units
			MIN	MAX	
Input Offset Voltage	$V_{OS}$		--	200	$\mu V$
		$-55^\circ C \leq T_A \leq +125^\circ C$	--	500	$\mu V$
Input Offset Current	$I_{OS}$	$V_{CM} = 0V$	--	3	nA
		$V_{CM} = 0V, -55^\circ C \leq T_A \leq +125^\circ C$	--	5	
Input Bias Current	$I_B$	$V_{CM} = 0V$	--	$\pm 15$	nA
		$V_{CM} = 0V, -55^\circ C \leq T_A \leq +125^\circ C$	--	$\pm 20$	
Large-Signal Voltage Gain	$A_{VO}$	$V_S = \pm 15V, V_O = \pm 10V,$ $R_L = 100k\Omega$	700	--	V/mV
		$V_S = \pm 15V, V_O = \pm 10V,$ $R_L = 100k\Omega,$ $-55^\circ C \leq T_A \leq +125^\circ C$	225	--	V/mV
		$V_S = \pm 15V, V_O = \pm 10V,$ $R_L = 10k\Omega$	350	--	V/mV
		$V_S = \pm 15V, V_O = \pm 10V,$ $R_L = 10k\Omega,$ $-55^\circ C \leq T_A \leq +125^\circ C$	125	--	V/mV
		$V_S = \pm 15V, V_O = \pm 10V,$ $R_L = 2k\Omega$	125	--	V/mV
		$V_S = \pm 15V, V_O = \pm 10V,$ $R_L = 2k\Omega,$ $-55^\circ C \leq T_A \leq +125^\circ C$	50	--	V/mV

TABLE 1 (Continued)

$V_S = \pm 1.5V$  and  $\pm 15V$ ;  $R_S = 50\Omega$ ;  $T_A = +25^\circ C$ ; unless otherwise specified.

Characteristics	Symbol	Special Conditions	OP-290/883 LIMITS A		Units
			MIN	MAX	
Large-Signal Voltage Gain  (Cont'd)	$A_{VO}$	$V_+ = +5V, V_- = 0V,$ $1V \leq V_O \leq 4V; R_L = 100k\Omega$	200	--	V/mV
		$V_+ = +5V, V_- = 0V,$ $1V \leq V_O \leq 4V; R_L = 100k\Omega$ $-55^\circ C \leq T_A \leq +125^\circ C$	100	--	V/mV
		$V_+ = +5V, V_- = 0V,$ $1V \leq V_O \leq 4V; R_L = 10k\Omega$	100	--	V/mV
		$V_+ = +5V, V_- = 0V,$ $1V \leq V_O \leq 4V; R_L = 10k\Omega$ $-55^\circ C \leq T_A \leq +125^\circ C$	50	--	V/mV
Output Voltage Swing	$V_O$	$V_S = \pm 15V, R_L = 10k\Omega$	$\pm 13.5$	--	V
		$V_S = \pm 15V, R_L = 10k\Omega,$ $-55^\circ C \leq T_A \leq +125^\circ C$	$\pm 13$	--	V
		$V_S = \pm 15V, R_L = 2k\Omega$	$\pm 10.5$	--	V
		$V_S = \pm 15V, R_L = 2k\Omega,$ $-55^\circ C \leq T_A \leq +125^\circ C$	$\pm 10$	--	V
Output Voltage Swing	$V_{OH}$	$V_+ = +5V, V_- = 0V, R_L = 2k\Omega$	4.0	--	V
		$V_+ = +5V, V_- = 0V, R_L = 2k\Omega,$ $-55^\circ C \leq T_A \leq +125^\circ C$	3.9	--	V

# OP-290

**TABLE 1 (Continued)**

$V_S = \pm 1.5V$  and  $\pm 15V$ ;  $R_S = 50\Omega$ ;  $T_A = +25^\circ C$ ; unless otherwise specified.

Characteristic	Symbol	Special Conditions	OP-290/883 LIMITS A		Units
			MIN	MAX	
Output Voltage Swing	$V_{OL}$	$V_+ = +5V, V_- = 0V, R_L = 10k\Omega$	--	50	$\mu V$
		$V_+ = +5V, V_- = 0V, R_L = 10k\Omega,$ $-55^\circ C \leq T_A \leq +125^\circ C$	--	100	$\mu V$
Common-Mode Rejection	CMR	$V_+ = +5V, V_- = 0V,$ $0V \leq V_{CM} \leq 4V$	90	--	dB
		$V_+ = +5V, V_- = 0V,$ $0V \leq V_{CM} \leq 3.5V,$ $-55^\circ C \leq T_A \leq +125^\circ C$	80	--	dB
Rejection		$V_S = \pm 15V,$ $-15V \leq V_{CM} \leq 13.5V$	100	--	dB
		$V_S = \pm 15V,$ $-15V \leq V_{CM} \leq 13.5V,$ $-55^\circ C \leq T_A \leq +125^\circ C$	90	--	dB
Power-Supply Rejection Ratio	PSRR	$V_S = \pm 1.5V, \pm 15V$	--	5.6	$\mu V/V$
		$V_S = \pm 1.5V, \pm 15V, -55^\circ C \leq T_A \leq +125^\circ C$	--	10	$\mu V/V$
Supply Current (Note 2)	$I_{SY}$	No Load, $V_S = \pm 1.5V$	--	30	$\mu A$
		No Load, $V_S = \pm 1.5V, -55^\circ C \leq T_A \leq +125^\circ C$	--	50	$\mu A$
		No Load, $V_S = \pm 15V$	--	40	$\mu A$
		No Load, $V_S = \pm 15V, -55^\circ C \leq T_A \leq +125^\circ C$	--	60	$\mu A$

**TABLE 1 (Continued)**

$V_S = \pm 1.5V$  and  $\pm 15V$ ;  $R_S = 50\Omega$ ;  $T_A = +25^\circ C$ ; unless otherwise specified.

Characteristic	Symbol	Special Conditions	OP-290/883 LIMITS A		Units
			MIN	MAX	
Slew Rate	SR	$V_S = \pm 15V$	5	--	V/ms
Input Offset Voltage Temperature Coefficient	$TCV_{OS}$	$V_S = \pm 15V$	--	3	$\mu V/^\circ C$

Note 1. IVR guaranteed by CMR test.

Note 2.  $I_{SY}$  limit = total of both amplifiers.

**TABLE 2**

OP-290/883

**Electrical Test Requirements  
For Class B Devices**

MIL-STD-883 Test Requirement	Subgroups (see Table 3)
Interim Electrical Parameters (pre Burn-In)	1
Final Electrical Test Parameters	1*, 2, 3,4,5,6
Group A Test Requirements	1,2,3,4,5,6,7,8

\* PDA applies to Subgroup 1 only.  
No other Subgroups are included in PDA.

**TABLE 3**  
**Group A Inspection**

$V_S = \pm 1.5V$  and  $\pm 15V$ ;  $R_S = 50\Omega$ ; unless otherwise specified.

Characteristic	Symbol	Special Conditions	OP-290/883 LIMITS A		Units
			MIN	MAX	
Subgroup 1. $T_A = +25^\circ C$	$V_{OS}$		--	200	$\mu V$
	$I_{OS}$	$V_{CM} = 0V$	--	3	nA
	$I_B$	$V_{CM} = 0V$	--	$\pm 15$	nA
	CMR (Note 1)	$V_+ = +5V, V_- = 0V, V_{CM} = 0V, 4V$ $V_S = \pm 15V, V_{CM} = -15V, 13.5V$	90	--	dB
			100	--	dB
	PSRR	$V_S = \pm 1.5V, \pm 15V$	--	5.6	$\mu V/V$
	$I_{SY}$ (Note 2)	$V_S = \pm 1.5V, \text{No Load}$ $V_S = \pm 15V, \text{No Load}$	--	30	$\mu A$
--			40	$\mu A$	
Subgroup 2. $T_A = +125^\circ C$	$V_{OS}$		--	500	$\mu V$
	$I_{OS}$	$V_{CM} = 0V$	--	5	nA
	$I_B$	$V_{CM} = 0V$	--	$\pm 20$	nA
	CMR (Note 1)	$V_+ = +5V, V_- = 0V, V_{CM} = 0V, 3.5V$ $V_S = \pm 15V, V_{CM} = -15V, 13.5V$	80	--	dB
			90	--	dB

**TABLE 3**

**Group A Inspection**

$V_S = \pm 1.5V$  and  $\pm 15V$ ;  $R_S = 50\Omega$ ; unless otherwise specified.

Characteristic	Symbol	Special Conditions	OP-290/883 LIMITS A		Units
			MIN	MAX	
<b>Subgroup 2.</b> $T_A = +125^\circ C$	PSRR	$V_S = \pm 1.5V, \pm 15V$	--	10	$\mu V/V$
(Cont'd)	$I_{SY}$ (Note 2)	$V_S = \pm 1.5V, \text{No Load}$	--	50	$\mu A$
		$V_S = \pm 15V, \text{No Load}$	--	60	$\mu A$
<b>Subgroup 3.</b> $T_A = -55^\circ C$	All Tests, Limits, and Conditions are the same as for Subgroup 2.				
<b>Subgroup 4.</b> $T_A = +25^\circ C$	$A_{VO}$	$V_S = \pm 15V, V_O = \pm 10V,$ $R_L = 100k\Omega$	700	--	V/mV
		$V_S = \pm 15V, V_O = \pm 10V,$ $R_L = 10k\Omega$	350	--	V/mV
		$V_S = \pm 15V, V_O = \pm 10V,$ $R_L = 2k\Omega$	125	--	V/mV
		$V_+ = +5V, V_- = 0V,$ $V_O = 1V, 4V; R_L = 100k\Omega$	200	--	V/mV
		$V_+ = +5V, V_- = 0V,$ $V_O = 1V, 4V; R_L = 10k\Omega$	100	--	V/mV
	$V_O$	$V_S = \pm 15V, R_L = 10k\Omega$	$\pm 13.5$	--	V
		$V_S = \pm 15V, R_L = 2k\Omega$	$\pm 10.5$	--	V
	$V_{OH}$	$V_+ = +5V, V_- = 0V$ $R_L = 2k\Omega$	4.0	--	V
	$V_{OL}$	$V_+ = +5V, V_- = 0V$ $R_L = 10k\Omega$	--	50	$\mu V$

12 OPERATIONAL AMPLIFIERS

**TABLE 3**  
**Group A Inspection**

$V_S = \pm 1.5V$  and  $\pm 15V$ ;  $R_S = 50\Omega$ ; unless otherwise specified.

Characteristic	Symbol	Special Conditions	OP-290/883 LIMITS A		Units
			MIN	MAX	
<b>Subgroup 5.</b> $T_A = +125^\circ C$	$A_{VO}$	$V_S = \pm 15V, V_O = \pm 10V,$ $R_L = 100k\Omega$	225	--	V/mV
		$V_S = \pm 15V, V_O = \pm 10V,$ $R_L = 10k\Omega$	125	--	V/mV
		$V_S = \pm 15V, V_O = \pm 10V,$ $R_L = 2k\Omega$	50	--	V/mV
		$V_+ = +5V, V_- = 0V,$ $V_O = 1V, 4V; R_L = 100k\Omega$	100	--	V/mV
		$V_+ = +5V, V_- = 0V,$ $V_O = 1V, 4V; R_L = 10k\Omega$	50	--	V/mV
$V_O$	$V_S = \pm 15V, R_L = 10k\Omega$	$\pm 13$	--	V	
	$V_S = \pm 15V, R_L = 2k\Omega$	$\pm 10$	--	V	
$V_{OH}$	$V_+ = +5V, V_- = 0V,$ $R_L = 2k\Omega$	3.9	--	V	
$V_{OL}$	$V_+ = +5V, V_- = 0V,$ $R_L = 10k\Omega$	--	100	$\mu V$	
<b>Subgroup 6.</b> $T_A = -55^\circ C$	All Tests, Limits, and Conditions are the same as for Subgroup 5.				



**TABLE 3**  
Group A Inspection

$V_S = \pm 1.5V$  and  $\pm 15V$ ;  $R_S = 50\Omega$ ; unless otherwise specified.

Characteristic	Symbol	Special Conditions	OP-290/883 LIMITS A		Units
			MIN	MAX	
Subgroup 7. $T_A = +25^\circ C$	SR	$V_S = \pm 15V$	5	--	V/ms
Subgroup 8. $T_A = -55^\circ C, +125^\circ C$	$TCV_{OS}$	$V_S = \pm 15V$	--	3	$\mu V/^\circ C$

Note 1.  $MR$  guaranteed by  $CMR$  test.  
Note 2.  $I_{SY}$  limit = total of both amplifiers.

**3.2.1 Simplified Schematic and Pin Connections**

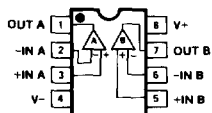
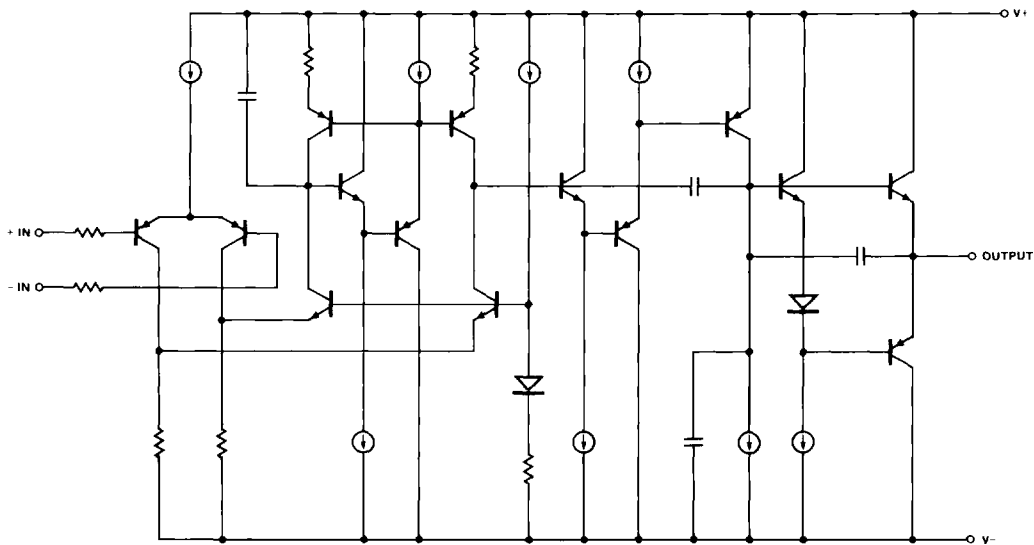

**8-PIN HERMETIC DIP**  
(Z-Suffix)

12 OPERATIONAL AMPLIFIERS