

PART NUMBER	REVISION	DESCRIPTION	FEED TYPE
2266507-1	B	FINE CRIMP HEIGHT ADJUST	MECHANICAL
2266507-2	B	FINE CRIMP HEIGHT ADJUST	PNEUMATIC
7-2266507-1	B	MECHANICAL AND CRIMP TOOLING KIT	MECHANICAL
7-2266507-2	B	PNEUMATIC AND CRIMP TOOLING KIT	PNEUMATIC
7-2266507-7	A	CRIMP TOOLING KIT	-

ATLANTIC VERSION TERMINATOR INTERFACE ADAPTER

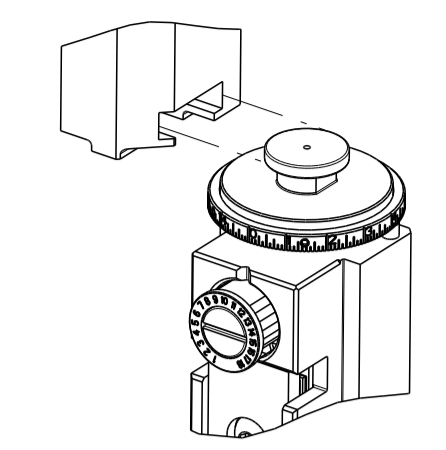

APPLICATOR DATA		
CRIMP	SIZE	TYPE
WIRE	1.62 mm [.064]	F
INSUL	3.73 mm [.147]	O
APPLICATOR INSTRUCTIONS 408-35042		

TERMINAL DATA: FCI/DELPHI TERMINAL DELPHI CRIMP SPECIFICATION	
TERMINAL NAME: TERMINAL	
WIRE STRIP LENGTH	INSULATION DIAMETER RANGE
3.50-4.10 mm [.138-.161 IN]	Ø1.20-1.40 mm [.047 -.055 IN]
TERMINAL APPLICATION SPECIFICATION	90841100 Rev L

TERMINALS APPLIED				
TE TERMINAL	FCI/DELPHI TERMINAL	TE SEAL	FCI/DELPHI SEAL	CABLE DIAMETER
2113589-1	60012911	60994015	2113590-1	Ø1.2-1.65
2113589-2	60012914	10779162	2113590-2	Ø1.2-1.65
2113589-3	60012111			
2113589-4	60012114			
2113589-5	60014011			
2113589-6	60014012			
2113589-7	60014214			
2113589-8	60110511			
2113589-9	60110514			
1-2113589-0	60110711			
1-2113589-1	60110714			
1-2113589-2	60110712			
1-2113589-3	F220300			
1-2113589-4	F198600			

WIRE SIZE	CRIMP HEIGHT mm [INCH]	CRIMP HEIGHT REFERENCE SETTING
0.35mm ²	1.01+/-0.05 [.040+/- .002]	6.2

- 1 RECOMMENDED SPARE PARTS
- 2 REFER TO SUPPLIED INSTRUCTION SHEET FOR CLEANING, LUBRICATION AND STORAGE OF APPLICATOR.
- 3 APPLY PART NUMBER 2-23419-6 LOCTITE TO THREADS OF ITEM 242.
- 4 CRIMP HEIGHT REFERENCE SETTING WAS THE SETTING USED WHEN THE APPLICATOR WAS QUALIFIED AT THE FACTORY. ADJUSTMENT MAY BE NECESSARY WHEN RUNNING APPLICATOR IN THE FIELD.
- 5 TERMINAL LUBRICANT IS RECOMMENDED.
- 6. UNLESS SPECIFIED OTHERWISE TORQUE VALUES SHALL BE USED PER DOCUMENT, 101-35000.
- 7 APPLY TORQ-SEAL IN ALLEN SOCKET TO FILL HOLE AFTER FLAT HD HAS BEEN ADJUSTED TO CORRECT HEIGHT AT QUALIFICATION. APPLY #1-23419-5 LOC-TITE TO THREADS.

***WARNING**
ON INSTALLATION, SET WIRE DISC TO CRIMP HEIGHT REFERENCE SETTING FOR LARGEST WIRE SIZE. CRIMP HEIGHT REFERENCE SETTINGS GREATER THAN THE VALUE SHOWN MAY CAUSE DAMAGE TO THE CRIMP TOOLING. REFER TO THE INSTRUCTION SHEET FOR PROPER SETUP AND ADJUSTMENTS.

TERMINAL DATA: FCI/DELPHI TERMINAL DELPHI CRIMP SPECIFICATION	
TERMINAL NAME: TERMINAL	
WIRE STRIP LENGTH	INSULATION DIAMETER RANGE
3.50-4.10 mm [.138-.161 IN]	Ø1.45-1.65 mm [.057-.065 IN]
TERMINAL APPLICATION SPECIFICATION	90841100 Rev L

TERMINALS APPLIED				
TE TERMINAL	FCI/DELPHI TERMINAL	TE SEAL	FCI/DELPHI SEAL	CABLE DIAMETER
2113589-1	60012911	60994015	2113590-1	Ø1.2-1.65
2113589-2	60012914	10779162	2113590-2	Ø1.2-1.65
2113589-3	60012111			
2113589-4	60012114			
2113589-5	60014011			
2113589-6	60014012			
2113589-7	60014214			
2113589-8	60110511			
2113589-9	60110514			
1-2113589-0	60110711			
1-2113589-1	60110714			
1-2113589-2	60110712			
1-2113589-3	F220300			
1-2113589-4	F198600			

WIRE SIZE	CRIMP HEIGHT mm [INCH]	CRIMP HEIGHT REFERENCE SETTING
22 AWG	1.01+/-0.05 [.040+/- .002]	6.2

LOC	DIST	REVISIONS					
A	66	P	LTN	DESCRIPTION	DATE	OWN	APVD
		1		DEVELOPMENT	16OCT2014	JH	UG
		A		RELEASED	18NOV2014	JH	TE
		A1		ECR-17-007560	25MAY2017	FZ	KZ
		B		ECR-21-005374	19MAY2021	JWC	TE

-	1	-	1	-	2119641-1	FEED CAM, AIR FEED	248
-	1	1	1	1	2119082-3	CAM, SNAIL, INSULATION ADJUSTMENT	244
-	1	1	1	1	2079764-1	WASHER, WAVE SPRING, CREST-TO-CREST	243
-	1	1	1	1	2119083-1	RETAINER, INSULATION DIAL	242
-	1	1	1	1	7-18023-7	SCR, SKT HD CAP M3 X 4.0	241
-	-	1	-	1	2119580-1	MECHANICAL FEED ASSEMBLY	239
-	1	-	1	-	2844940-1	AIR FEED MODULE	238
-	REF	REF	REF	REF	994970-2	COUNTER, MAGNETIC	164
-	1	1	1	1	2119955-1	ASSY, LUBRICATOR, SIDE FEED	113
-	1	1	1	1	2844908-1	SCREW, LOCKING	99
-	1	1	1	1	2844907-1	POST, LOCKING	98
-	1	1	1	1	318563-1	GUARD, FRONT CHIP	89
-	1	1	1	1	455888-5	SPACER, CRIMPER	82
-	1	1	1	1	1803607-3	DOCUMENTATION PACKAGE	71
-	1	1	1	1	2119740-1	TAG, IDENTIFICATION	67
-	2	2	2	2	2168078-1	SCREW, DRIVE, RH, RoHS, 2 x .188	66
-	1	1	1	1	2168083-2	SCR, SKT HD CAP, RoHS, M4 X 8.0	60
-	1	1	1	1	5-18022-5	SCR, HEX HD CAP, M4 X 6.0	59
-	1	1	1	1	985575-3	SCR, FLT SKT HD CAP M3 X 10.0	57
-	1	1	1	1	1338683-8	FEED PAWL	56
-	4	4	4	4	2168083-3	SCR, SKT HD CAP, RoHS, M4 X 12.0	54
-	2	2	2	2	1-2168083-0	SCR, SKT HD CAP, RoHS, M4 X 10	53
-	1	1	1	1	5018030-1	NUT, HEX, REG, RoHS, M3	52
-	1	1	1	1	811242-5	BUMPER, HOLD DOWN	51
-	1	1	1	1	690753-2	SPACER, TONKER	50
-	1	2	1	2	18023-9	SCR, SKT HD CAP M4 X 6.0	49
-	-	1	-	1	2119652-1	FEED CAM, PRE FEED	48
-	-	1	-	1	2119653-1	FEED CAM, POST FEED	47
-	1	1	1	1	1803583-9	APPLICATOR BASIC ASSEMBLY, SF	46
-	1	1	1	1	1803515-1	RAM ASSEMBLY, SF ATLANTIC	44
-	1	1	1	1	1803602-1	SCR, BHSC, RoHS (M8 X 25)	41
-	1	1	1	1	1-1752356-7	SUPPORT, TERMINAL	34
-	2	2	2	2	2079383-5	SCR, BHSC, RoHS (M4 X 20)	33
-	2	2	2	2	3-2844962-2	SPACER, CYLINDRICAL, STRIP GUIDE	30
-	1	1	1	1	2844992-2	ASSEMBLY, STRIP GUIDE	29
-	1	1	1	1	455888-3	SPACER, CRIMPER	28
-	1	1	1	1	1320928-2	STRIP GUIDE	24
-	1	1	1	1	2168083-2	SCR, SKT HD CAP, RoHS, M4 X 8.0	21
-	2	2	2	2	1-18028-2	WASHER, FLAT, REG M4	20
-	1	1	1	1	2119533-1	STRIPPER, SIDE FEED	19
-	1	1	1	1	2119806-1	INSERT, SHEAR	13
-	1	1	1	1	3-22280-3	SPRING, COMPRESSION	12
-	1	1	1	1	1-356885-4	STOP, SHEAR	11
-	1	1	1	1	2119805-1	SHEAR HOLDER, FRONT	10
-	1	1	1	1	318707-1	FLOATING SHEAR, FRONT	9
-	1	2	2	1	1-1803171-7	ANVIL, COMBINATION	8
-	-	-	-	-	-	-	7
-	-	-	-	-	-	-	6
-	1	1	1	1	2-2119781-4	DEPRESSOR, SHEAR	5
-	1	1	1	1	238011-8	BLOCK, CRIMPER SPACER	4
-	1	2	2	1	8-1633965-0	CRIMPER, INSULATION O PREMIUM	3
-	1	1	1	1	1-455888-4	SPACER, CRIMPER	2
-	1	2	2	1	7-1633664-5	CRIMPER, WIRE	1

ATLANTIC VERSION
Shown on sheets 1 of 4 & 2 of 4
(Pacific version shown on sheets 3 of 4 & 4 of 4)

DIMENSIONS:		TOLERANCES UNLESS OTHERWISE SPECIFIED:		MATERIAL:	
mm	0 PLC ±	1 PLC ±	2 PLC ±	3 PLC ±	4 PLC ±
	ANGLES ±	FINISH ±			

OWN	CHK	Y.Y.N	APVD	U.GUO	DATE	NAME	SIZE	CAGE CODE	DRAWING NO	RESTRICTED TO
J.HOU					16OCT2014	TE Connectivity	A1	00779	2266507	Customer Accessible Production Drawing

LOC	DIST	REVISIONS					
A	66	P	LTN	DESCRIPTION	DATE	OWN	APVD
		-		SEE SHEET 1	-	-	-

FEED TYPE MECHANICAL

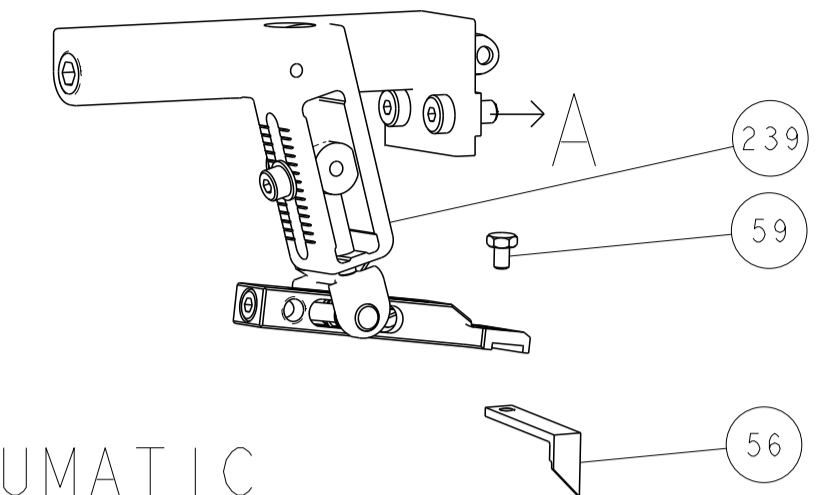

PNEUMATIC

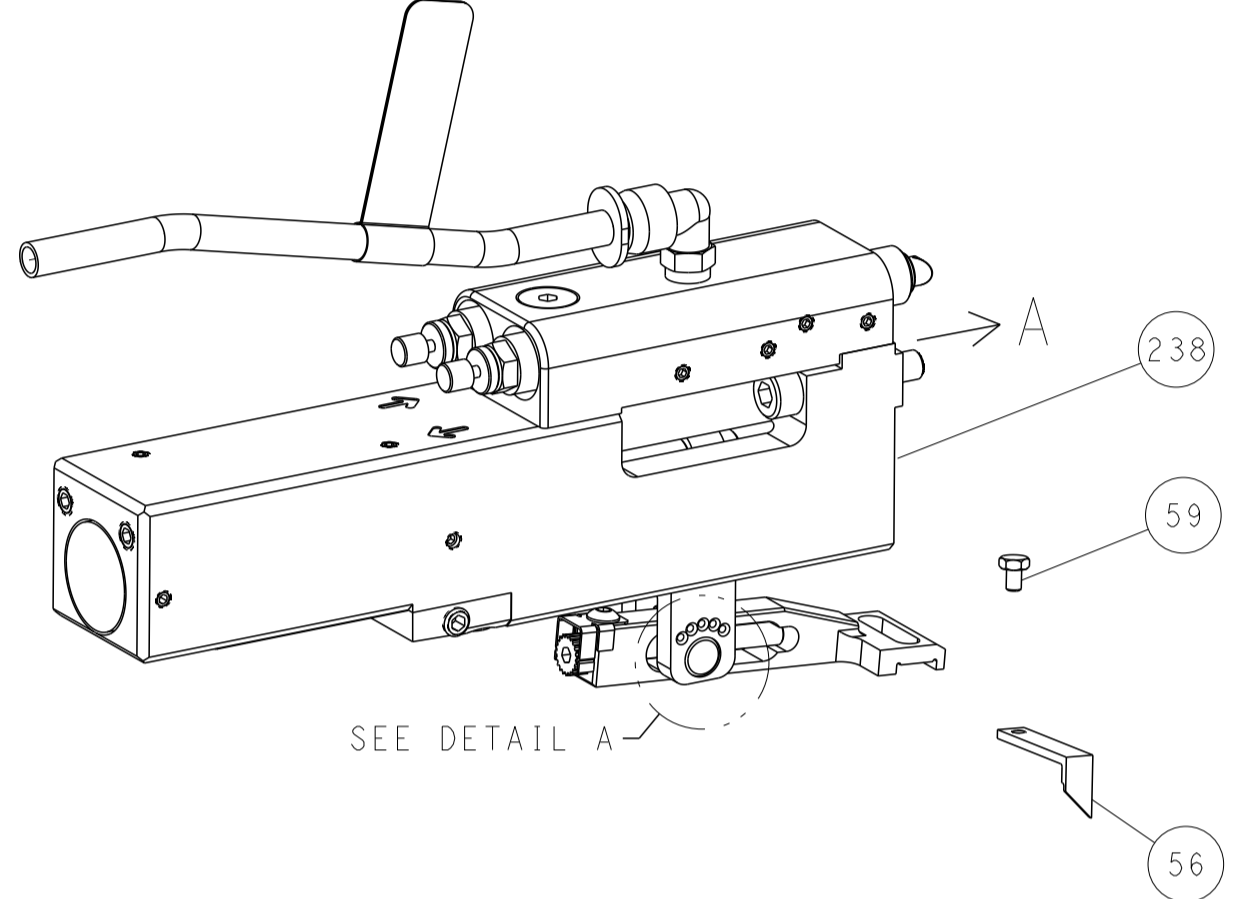

FEED SPRING SETTING POSITION (SHOWN FROM REAR SIDE)



DETAIL A

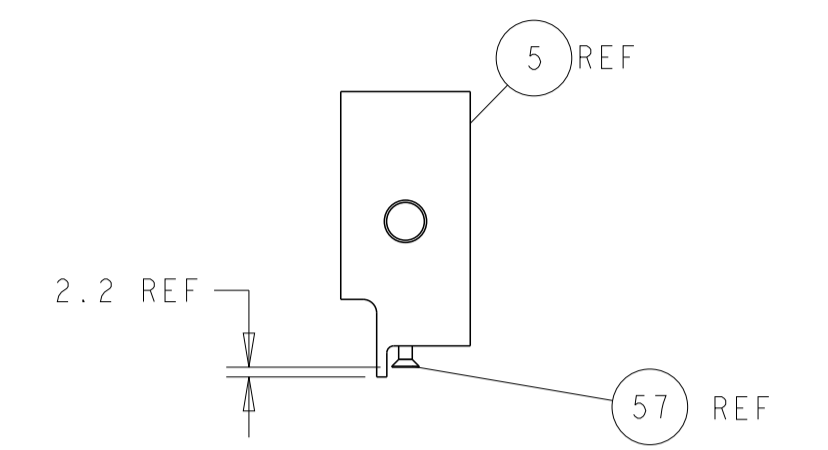
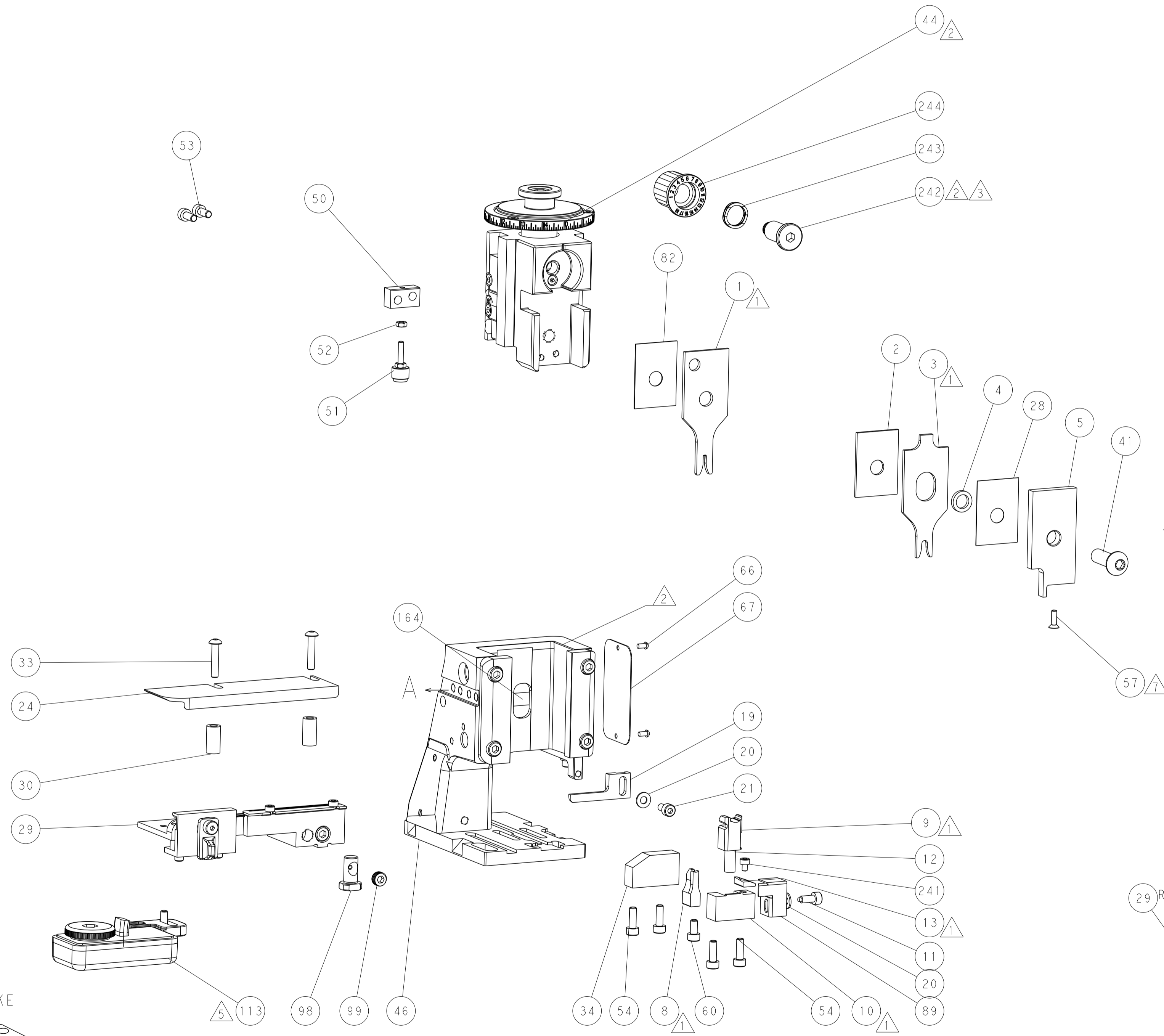

SHEAR DEPRESSOR DETAIL

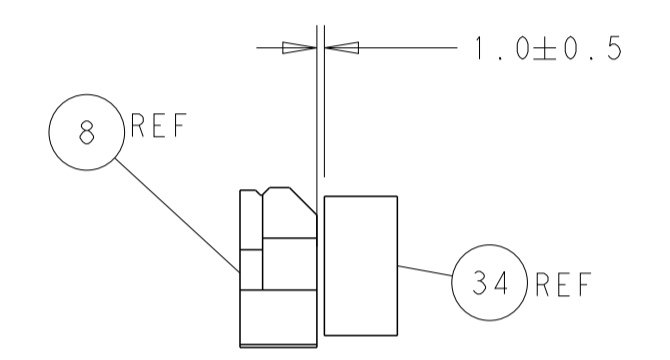

TERMINAL SUPPORT LOCATION

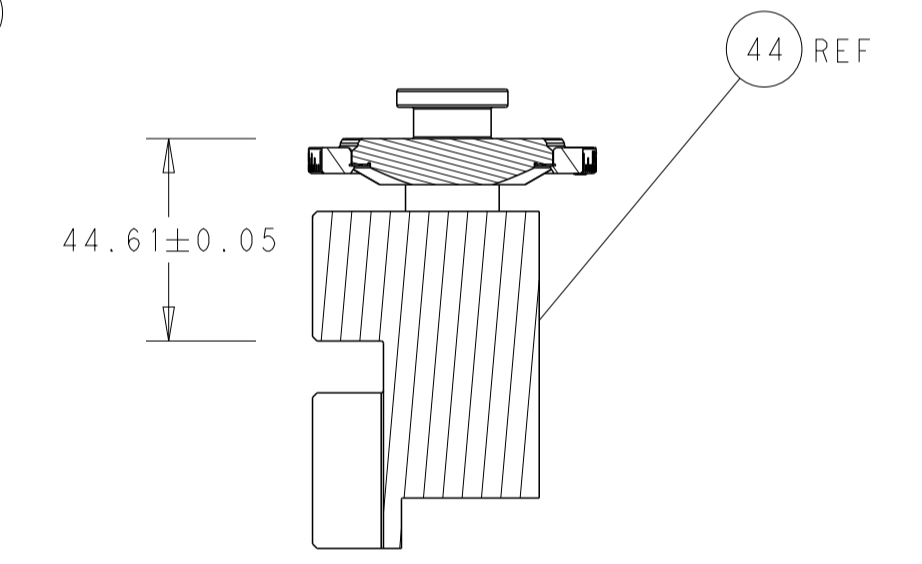

RAM SET-UP

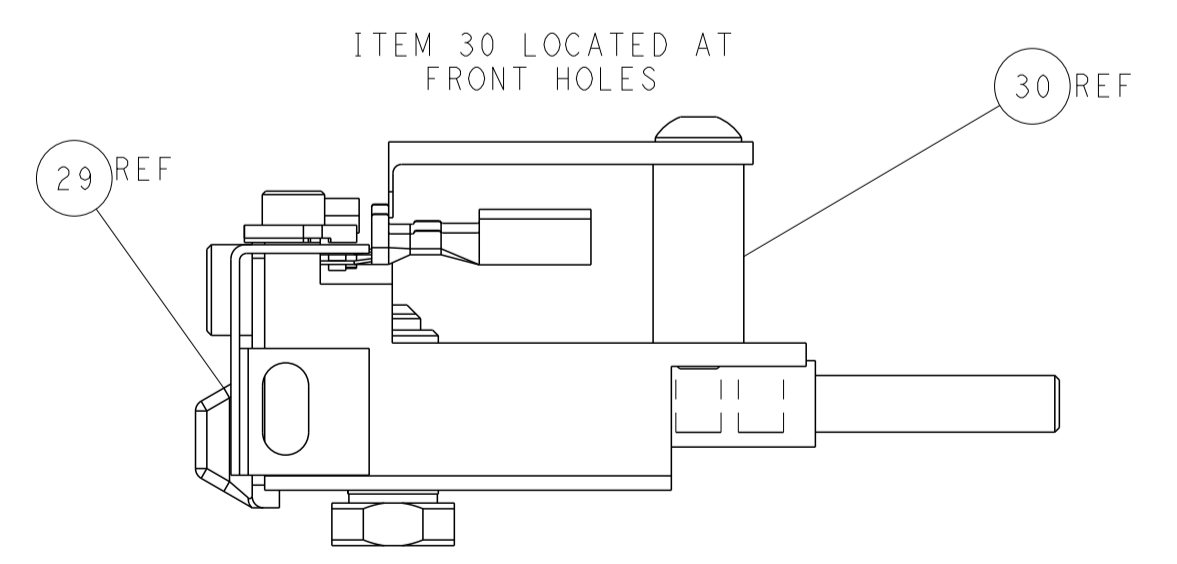

FEED TRACK POSITION GUIDE BY INSULATION BARREL

CAM POSITIONS

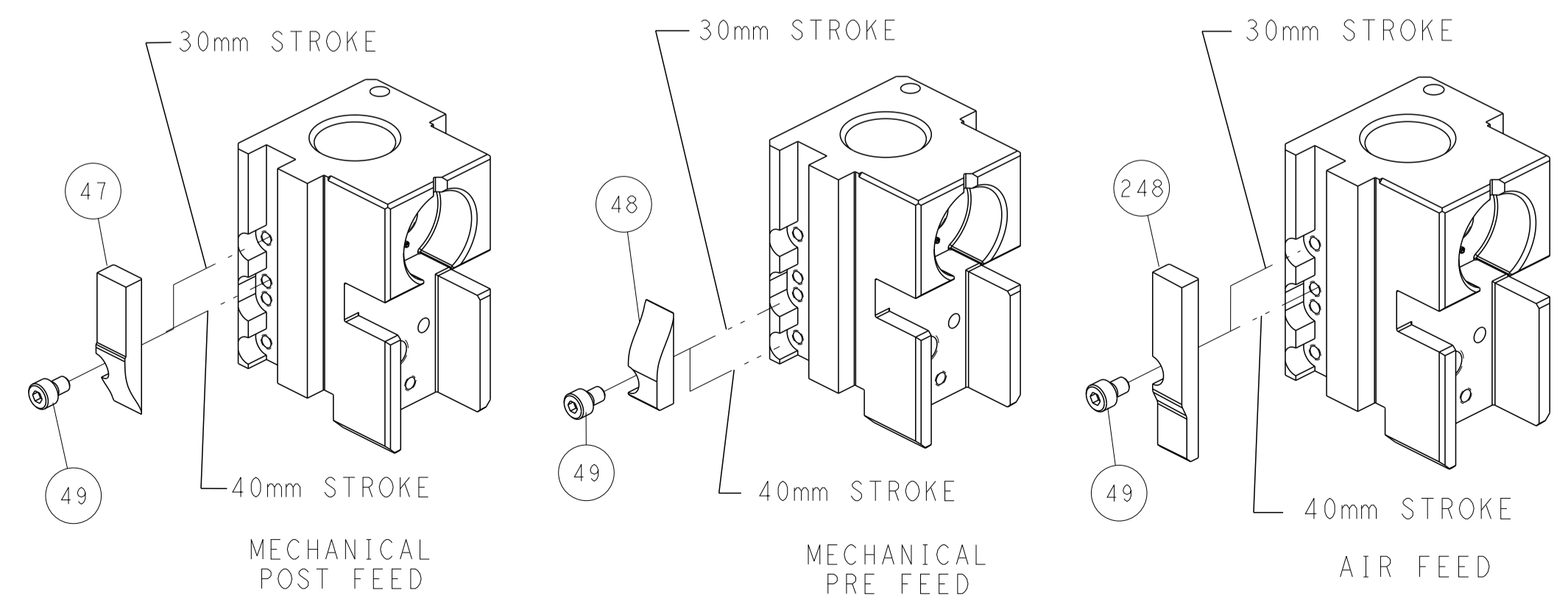

ATLANTIC VERSION
 Shown on sheets 1 of 4 & 2 of 4
 (Pacific version shown on sheets 3 of 4 & 4 of 4)

DIMENSIONS: mm 		TOLERANCES UNLESS OTHERWISE SPECIFIED: 0 PLC ± 1 PLC ± 2 PLC ± 3 PLC ± 4 PLC ± ANGLES ± FINISH		DWN J.HOU 16OCT2014 CHK Y.YIN 16OCT2014 APVD H.GUO 16OCT2014 NAME Ocean Side Feed Applicator SIZE CAGE CODE DRAWING NO. RESTRICTED TO A1 00779 ©=2266507 Customer Accessible Production Drawing SCALE 1:2 SHEET 2 OF 4 REV B	
MATERIAL:				WEIGHT:	

PART NUMBER	REVISION	DESCRIPTION	FEED TYPE
2-2266507-1	B	FINE CRIMP HEIGHT ADJUST	MECHANICAL
2-2266507-2	B	FINE CRIMP HEIGHT ADJUST	PNEUMATIC
7-2266507-7	A	CRIMP TOOLING KIT	-

PACIFIC VERSION TERMINATOR
INTERFACE ADAPTER



APPLICATOR DATA		
CRIMP	SIZE	TYPE
WIRE	1.62 mm [.064]	F
INSUL	3.73 mm [.147]	O

APPLICATOR INSTRUCTIONS
408-35042

TERMINAL DATA: FCI/DELPHI TERMINAL DELPHI CRIMP SPECIFICATION
TERMINAL NAME: TERMINAL

WIRE STRIP LENGTH 3.50-4.10 mm [1.38-.161 IN]	INSULATION DIAMETER RANGE Ø1.20-1.40 mm [.047 - .055 IN]
TERMINAL APPLICATION SPECIFICATION 90841100 Rev L	

TERMINALS APPLIED

TE TERMINAL	FCI/DELPHI TERMINAL	TE SEAL	FCI/DELPHI SEAL	CABLE DIAMETER
2113589-1	60012911	60994015	2113590-1	Ø1.2-1.65
2113589-2	60012914	10779162	2113590-2	Ø1.2-1.65
2113589-3	60012111			
2113589-4	60012114			
2113589-5	60014011			
2113589-6	60014012			
2113589-7	60014214			
2113589-8	60110511			
2113589-9	60110514			
1-2113589-0	60110711			
1-2113589-1	60110714			
1-2113589-2	60110712			
1-2113589-3	F220300			
1-2113589-4	F198600			

WIRE SIZE 0.35mm ²	CRIMP HEIGHT mm [INCH] 1.01+/-0.05 [1.040+/-0.002]	CRIMP HEIGHT REFERENCE SETTING 6.2
----------------------------------	--	---------------------------------------

TERMINAL DATA: FCI/DELPHI TERMINAL DELPHI CRIMP SPECIFICATION
TERMINAL NAME: TERMINAL

WIRE STRIP LENGTH 3.50-4.10 mm [1.38-.161 IN]	INSULATION DIAMETER RANGE Ø1.45-1.65 mm [.057-.065 IN]
TERMINAL APPLICATION SPECIFICATION 90841100 Rev L	

TERMINALS APPLIED

TE TERMINAL	FCI/DELPHI TERMINAL	TE SEAL	FCI/DELPHI SEAL	CABLE DIAMETER
2113589-1	60012911	60994015	2113590-1	Ø1.2-1.65
2113589-2	60012914	10779162	2113590-2	Ø1.2-1.65
2113589-3	60012111			
2113589-4	60012114			
2113589-5	60014011			
2113589-6	60014012			
2113589-7	60014214			
2113589-8	60110511			
2113589-9	60110514			
1-2113589-0	60110711			
1-2113589-1	60110714			
1-2113589-2	60110712			
1-2113589-3	F220300			
1-2113589-4	F198600			

WIRE SIZE 22 AWG	CRIMP HEIGHT mm [INCH] 1.01+/-0.05 [1.040+/-0.002]	CRIMP HEIGHT REFERENCE SETTING 6.2
---------------------	--	---------------------------------------

*WARNING

ON INSTALLATION, SET WIRE DISC TO CRIMP HEIGHT REFERENCE SETTING FOR LARGEST WIRE SIZE. CRIMP HEIGHT REFERENCE SETTINGS GREATER THAN THE VALUE SHOWN MAY CAUSE DAMAGE TO THE CRIMP TOOLING. REFER TO THE INSTRUCTION SHEET FOR PROPER SETUP AND ADJUSTMENTS.

LOC	DIST	REV	DATE	BY	APPV
A	66				

REV	DATE	DESCRIPTION	DATE	BY	APPV
-	1	1	2119082-3	CAM, SNAIL, INSULATION ADJUSTMENT	244
-	1	1	2079764-1	WASHER, WAVE SPRING, CREST-TO-CREST	243
-	1	1	2119083-1	RETAINER, INSULATION DIAL	242
-	1	1	7-18023-7	SCR, SKT HD CAP M3 X 4.0	241
-	-	1	2119580-1	MECHANICAL FEED ASSEMBLY	239
-	1	-	2844940-1	AIR FEED MODULE	238
-	REF	REF	994970-2	COUNTER, MAGNETIC	164
-	1	-	2119641-2	FEED CAM, AIR FEED	151
-	1	1	2168083-8	SCR, SKT HD CAP, RoHS, M4 X 16	144
-	4	4	2168083-9	SCR, SKT HD CAP, RoHS, M4 X 20	143
-	-	1	2119653-2	FEED CAM, POST FEED	142
-	1	1	1-1803583-0	APPLICATOR BASIC ASSEMBLY, SF	141
-	1	1	1803516-1	RAM ASSEMBLY, SF PACIFIC	140
-	1	1	2119955-1	ASSY, LUBRICATOR, SIDE FEED	113
-	1	1	2844908-1	SCREW, LOCKING	99
-	1	1	2844907-1	POST, LOCKING	98
-	1	1	318563-1	GUARD, FRONT CHIP	89
-	1	1	455888-5	SPACER, CRIMPER	82
-	1	1	1803607-3	DOCUMENTATION PACKAGE	71
-	1	1	2119740-1	TAG, IDENTIFICATION	67
-	2	2	2168078-1	SCREW, DRIVE, RH, RoHS, 2 x .188	66
-	1	1	5-18022-5	SCR, HEX HD CAP, M4 X 6.0	59
-	1	1	985575-3	SCR, FLT SKT HD CAP M3 X 10.0	57
-	1	1	1338683-8	FEED PAWL	56
-	2	2	1-2168083-0	SCR, SKT HD CAP, RoHS, M4 X 10	53
-	1	1	5018030-1	NUT, HEX, REG, RoHS, M3	52
-	1	1	811242-5	BUMPER, HOLD DOWN	51
-	1	1	690753-2	SPACER, TONKER	50
-	1	2	18023-9	SCR, SKT HD CAP M4 X 6.0	49
-	-	1	2119652-1	FEED CAM, PRE FEED	48
-	1	1	1803602-1	SCR, BHSC, RoHS (M8 X 25)	41
-	1	1	1-1752356-7	SUPPORT, TERMINAL	34
-	2	2	2079383-5	SCR, BHSC, RoHS (M4 X 20)	33
-	2	2	3-2844962-2	SPACER, CYLINDRICAL, STRIP GUIDE	30
-	1	1	2844992-2	ASSEMBLY, STRIP GUIDE	29
-	1	1	455888-3	SPACER, CRIMPER	28
-	1	1	1320928-2	STRIP GUIDE	24
-	1	1	2168083-2	SCR, SKT HD CAP, RoHS, M4 X 8.0	21
-	2	2	1-18028-2	WASHER, FLAT, REG M4	20
-	1	1	2119533-1	STRIPPER, SIDE FEED	19
-	1	1	2119806-1	INSERT, SHEAR	13
-	1	1	3-22280-3	SPRING, COMPRESSION	12
-	1	1	1-356885-4	STOP, SHEAR	11
-	1	1	2119805-1	SHEAR HOLDER, FRONT	10
-	1	1	318707-1	FLOATING SHEAR, FRONT	9
-	1	1	1-1803171-7	ANVIL, COMBINATION	8
-	-	-	-	-	7
-	-	-	-	-	6
-	1	1	2-2119781-4	DEPRESSOR, SHEAR	5
-	1	1	238011-8	BLOCK, CRIMPER SPACER	4
-	1	1	8-1633965-0	CRIMPER, INSULATION O PREMIUM	3
-	1	1	1-455888-4	SPACER, CRIMPER	2
-	1	1	7-1633664-5	CRIMPER, WIRE	1

REV	DATE	DESCRIPTION	ITEM NO
-77	-22	-21	
		PART NO	
		DESCRIPTION	

PACIFIC VERSION
Shown on sheets 3 of 4 & 4 of 4
(Atlantic version shown on sheets 1 of 4 & 2 of 4)

THIS DRAWING IS CONTROLLED DOCUMENT AND MUST BE USED IN CONFORMANCE WITH THE INSTRUCTIONS TO CONTROLLED DOCUMENTS AND THE INSTRUCTIONS TO CONTROLLED DOCUMENTS WHICH ARE LOCATED IN THE DRAWING.	OWN J. HOU CHK Y. YIN APVD J. GUO	16OCT2014 16OCT2014 16OCT2014	NAME Ocean Side Feed Applicator
DIMENSIONS: mm	TOLERANCES UNLESS OTHERWISE SPECIFIED: 0 PLC ± 1 PLC ± 2 PLC ± 3 PLC ± 4 PLC ± ANGLES ±	SIZE A1	CAGE CODE 00779
MATERIAL	FINISH	WEIGHT	SCALE 1:2
			SHEET 3 OF 4

LOC	DIST	REVISIONS					
A	66	P	LTN	DESCRIPTION	DATE	OWN	APVD
		-		SEE SHEET 1	-	-	-

FEED TYPE MECHANICAL

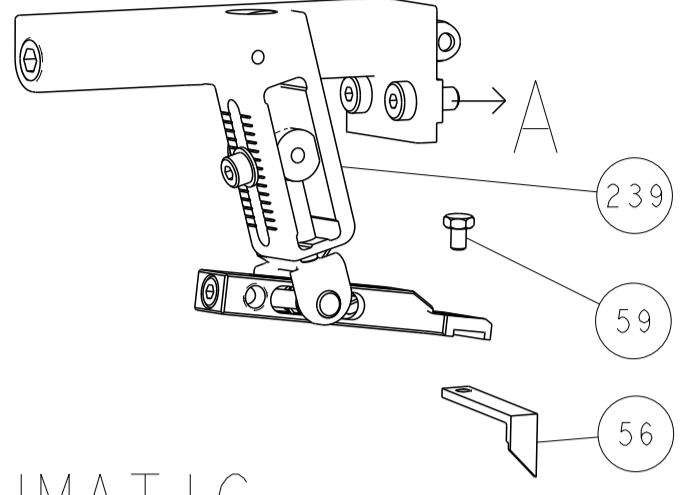

PNEUMATIC

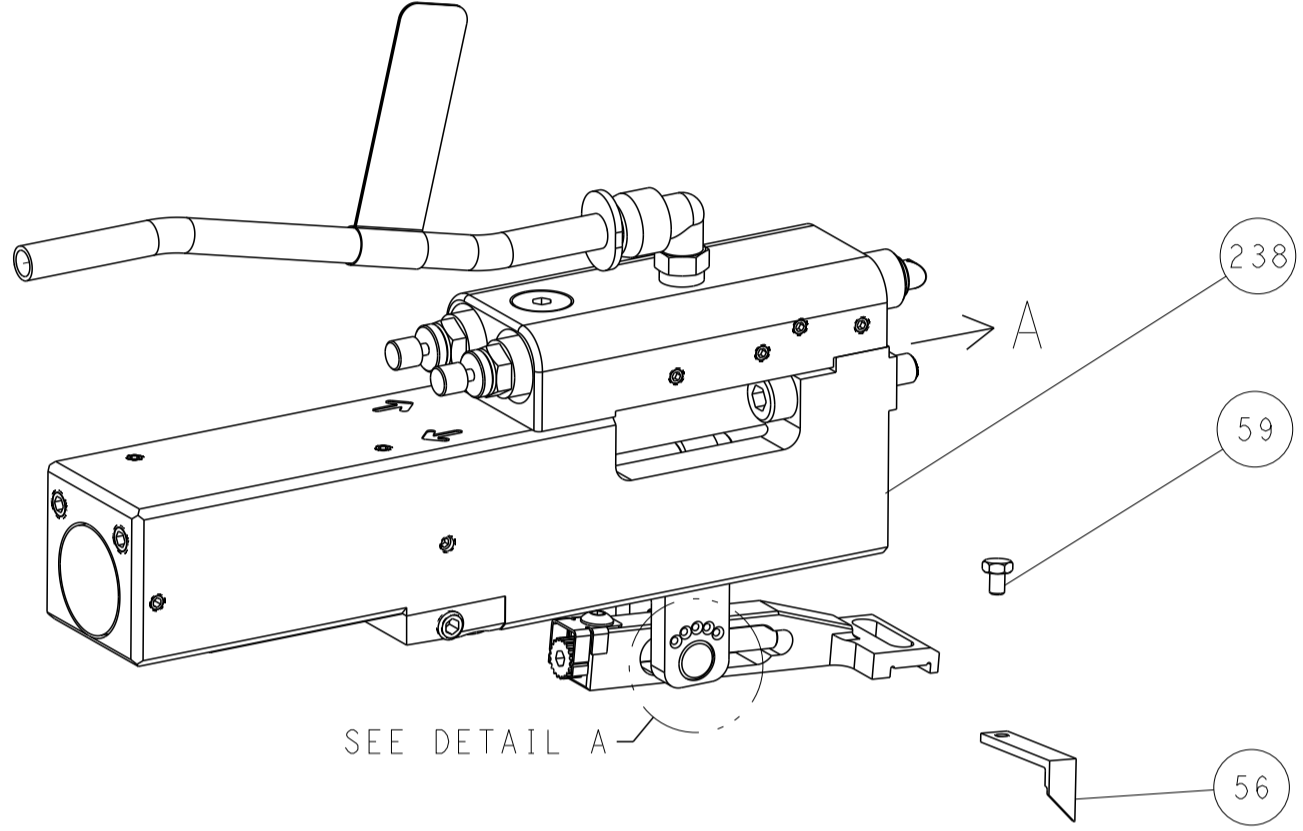

FEED SPRING SETTING POSITION (SHOWN FROM REAR SIDE)

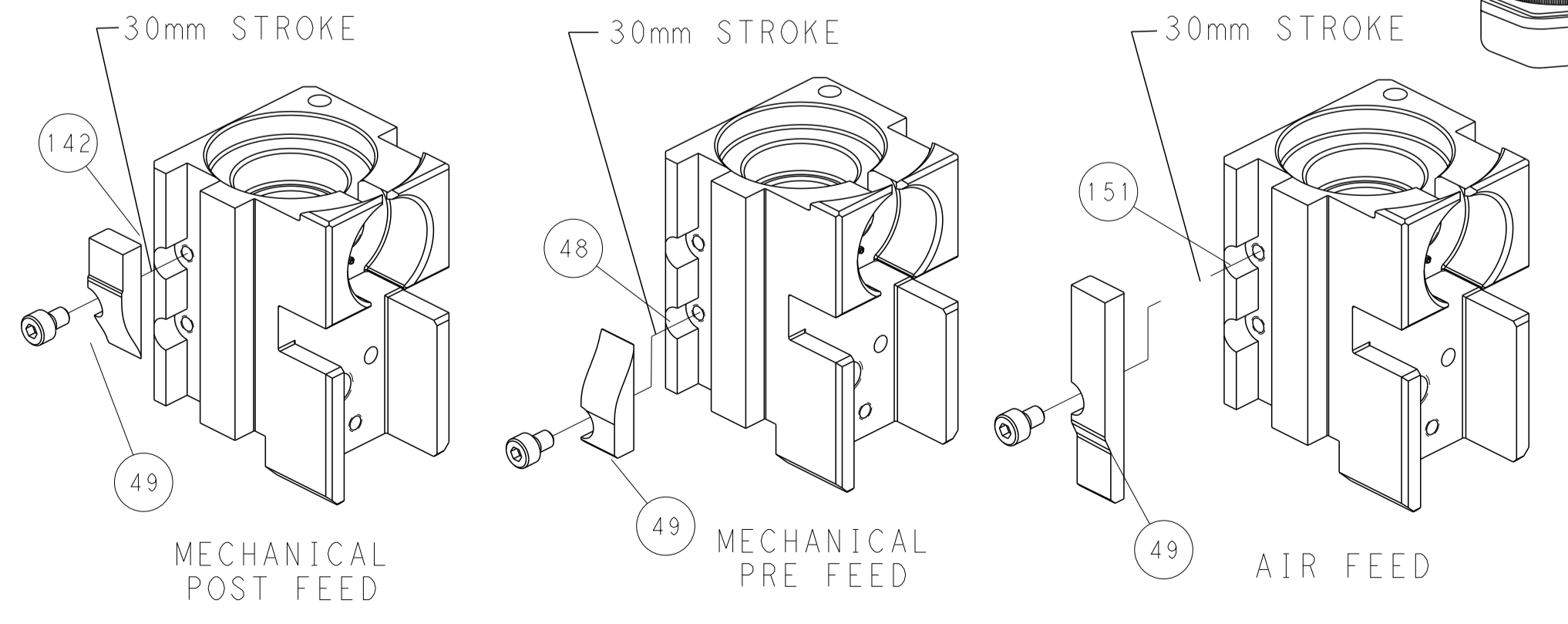
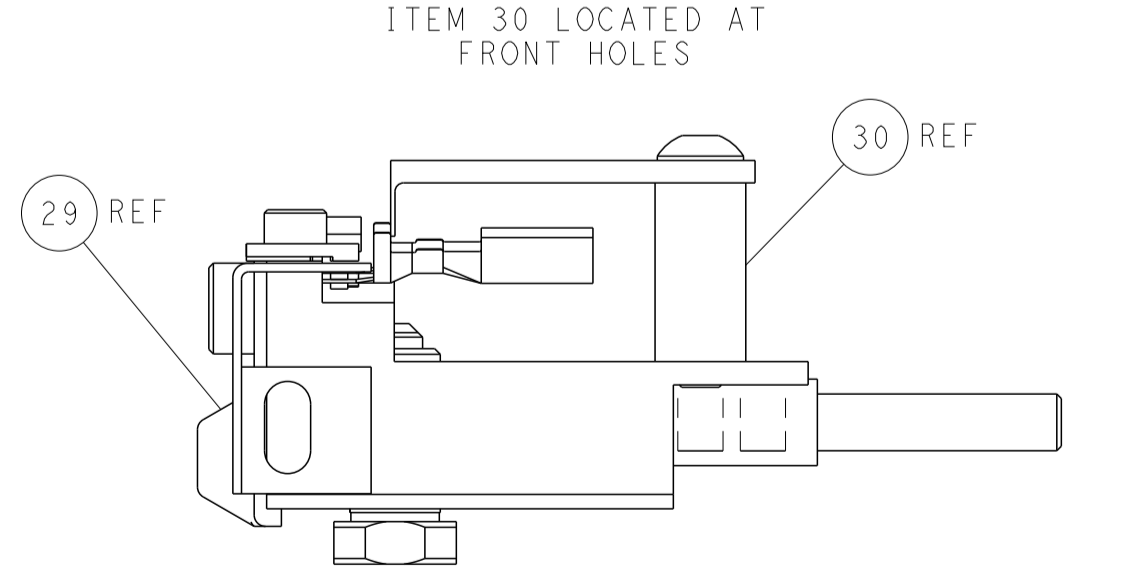
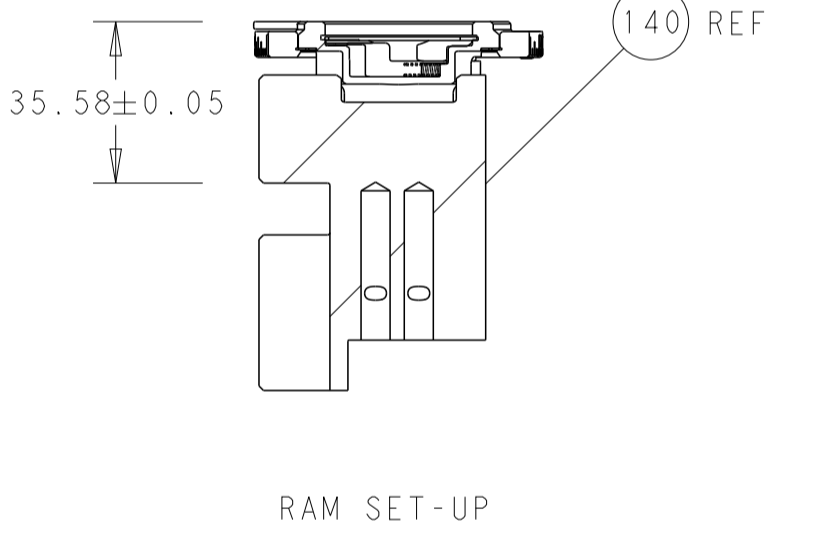
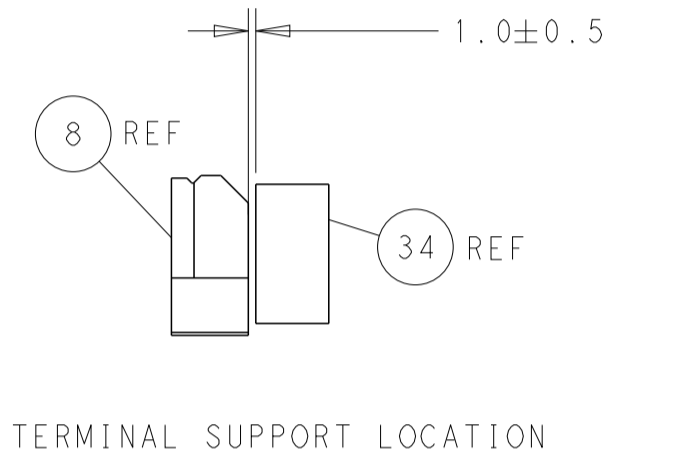
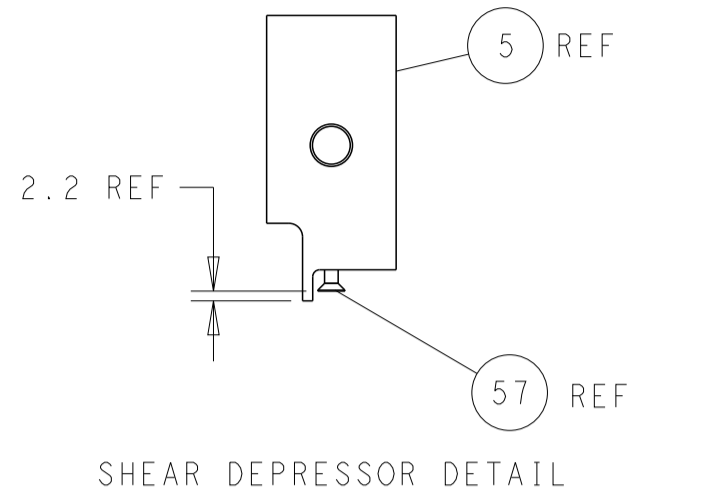
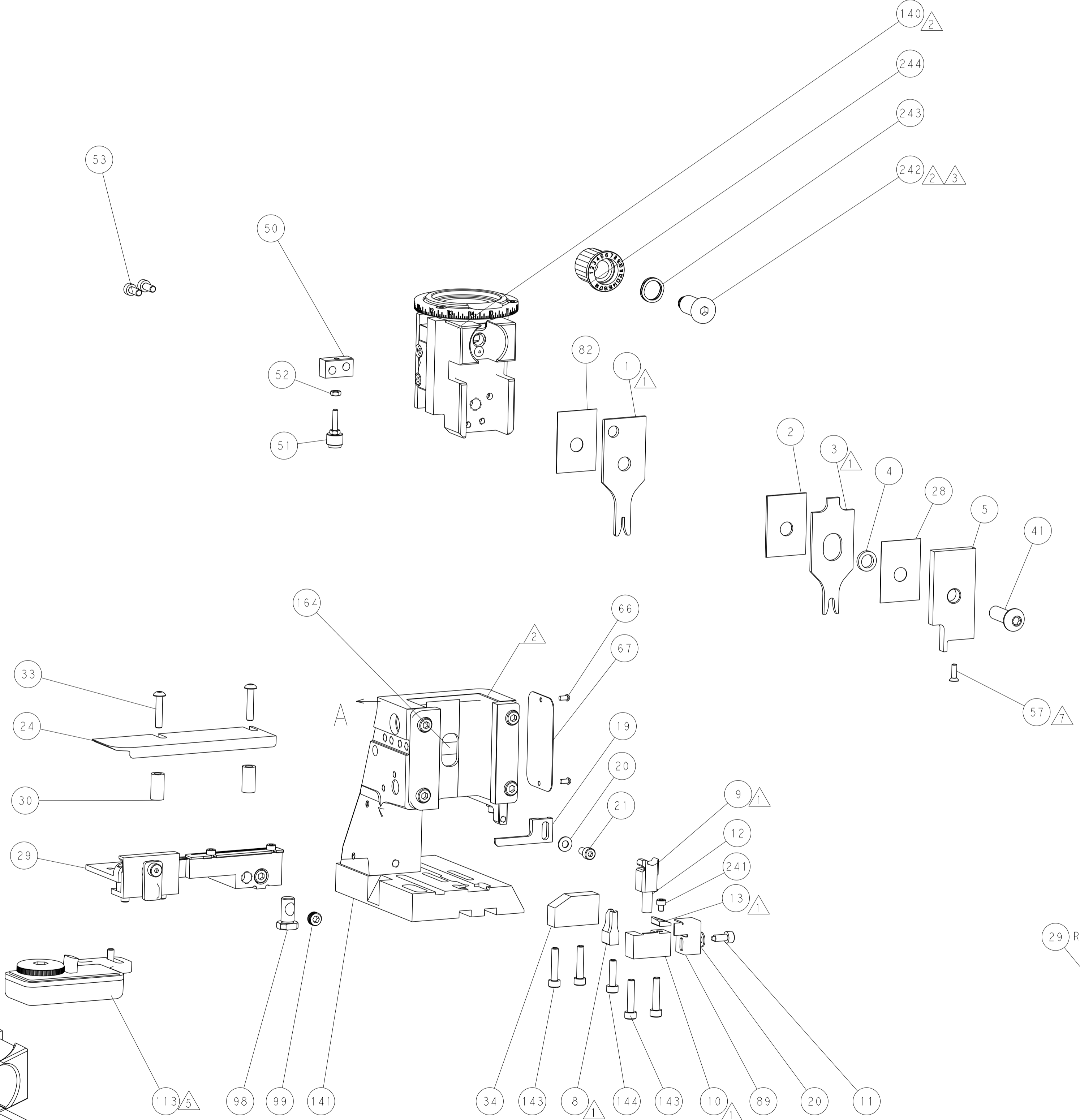
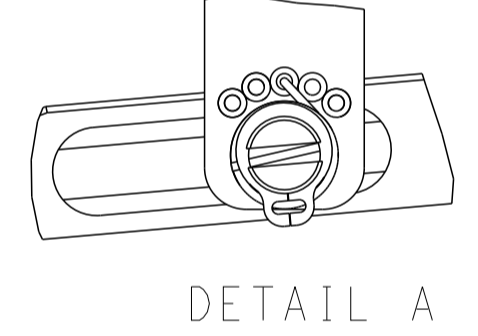

PACIFIC VERSION
 Shown on sheets 3 of 4 & 4 of 4
 (Atlantic version shown on sheets 1 of 4 & 2 of 4)

DIMENSIONS:		TOLERANCES UNLESS OTHERWISE SPECIFIED:		DWG: J.HOU 16OCT2014		TE Connectivity	
mm	0 PLC ±	1 PLC ±	2 PLC ±	3 PLC ±	4 PLC ±	Harrisburg, PA 17105-3608	
	ANGLES ±	FINISH ±		APVD: J.GUO 16OCT2014	NAME: Ocean Side Feed Applicator		
MATERIAL:				PRODUCT SPEC:	SIZE: A1	CAGE CODE: 00779	DRAWING NO: C=2266507
				APPLICATION SPEC:	WEIGHT:	SCALE: 1:2	SHEET 4 OF 4 REV B
				Customer Accessible Production Drawing			