

PART NAME: KNOB SCALE: 1:1 DATE: 10/4/13 DR. BY JAM

THIS DRAWING IS THE PROPERTY OF DAVIES MOLDING COMPANY, IS SUBMITTED SOLELY AS A DESIGN OR ENGINEERING PROJECT. WE ACCEPT NO RESPONSIBILITY WHATSOEVER FOR THE PRACTICAL APPLICATION OF THE PIECES MADE TO THIS DESIGN.



DESIGNERS & MANUFACTURERS
OF KNOBS, HANDLES, CASES &
CUSTOM PLASTIC COMPONENTS

P/N 3025HB

M NO. 3025

CAVITY	3025
PLUNGER	3025
SLEEVE	3025-2
SHIMS	1/4+1/8
INSERT	I2353
PLUNGER PIN	3025-A

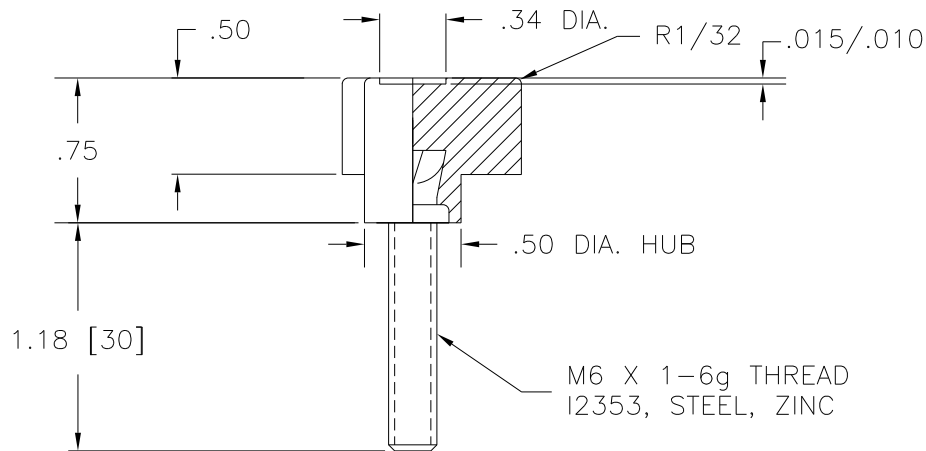
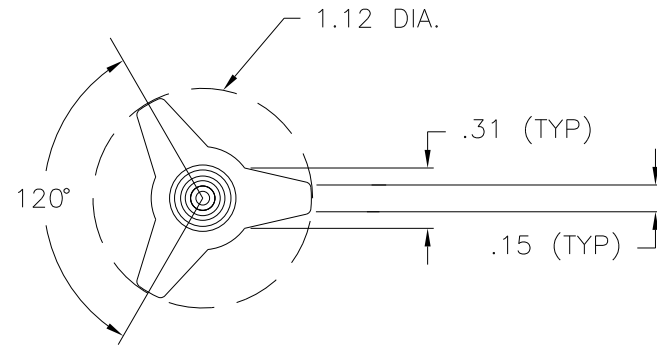

MATERIAL: G.P. PHENOLIC (B11)
COLOR: BLACK

TOLERANCES: UNLESS OTHERWISE SPECIFIED	DO NOT SCALE DRAWING				
DECIMALS: X.XXX ± .005 X.XX ± .015	MM: X.XX ± 0.15MM X.X ± 0.4MM	-	WAS SK3025-68	JAM	10/4/13
FRACTIONS ± 1/64	ANG. ± 1°	CHANGES			