

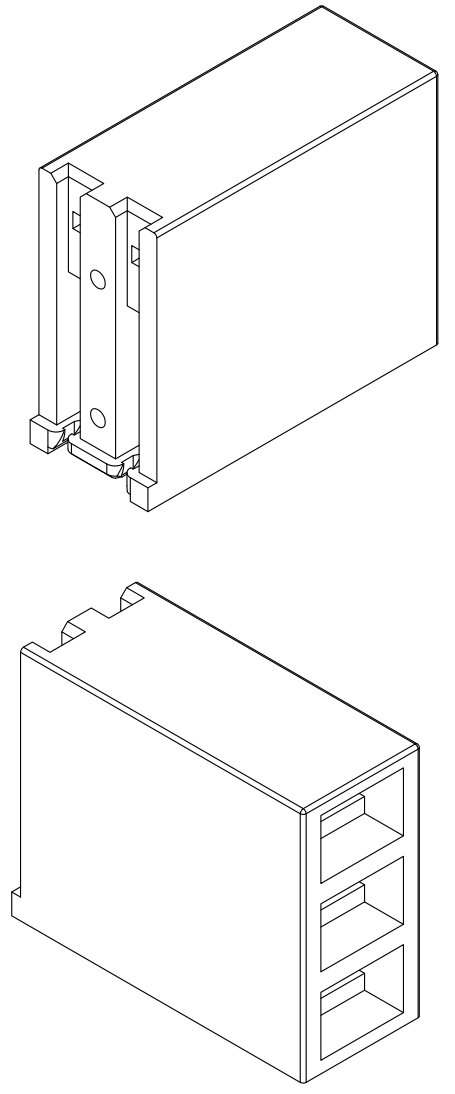

REV.	DESCRIPTION	DATE	APPROVED
A	Engineering Update w/o Changes	05/16/07	M. C.
B	Rear Plate Update	10/15/07	M. C.
C	Updated Title Block	02/07/08	M. C.
D	Removed Material Code	05/28/16	J. C.

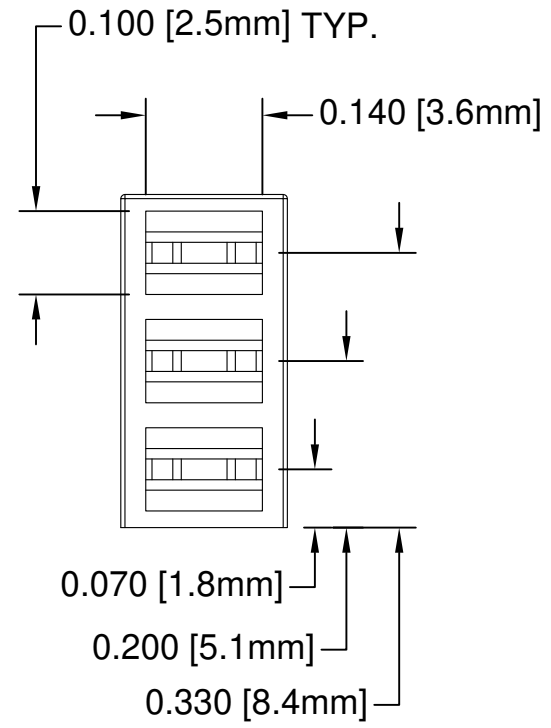
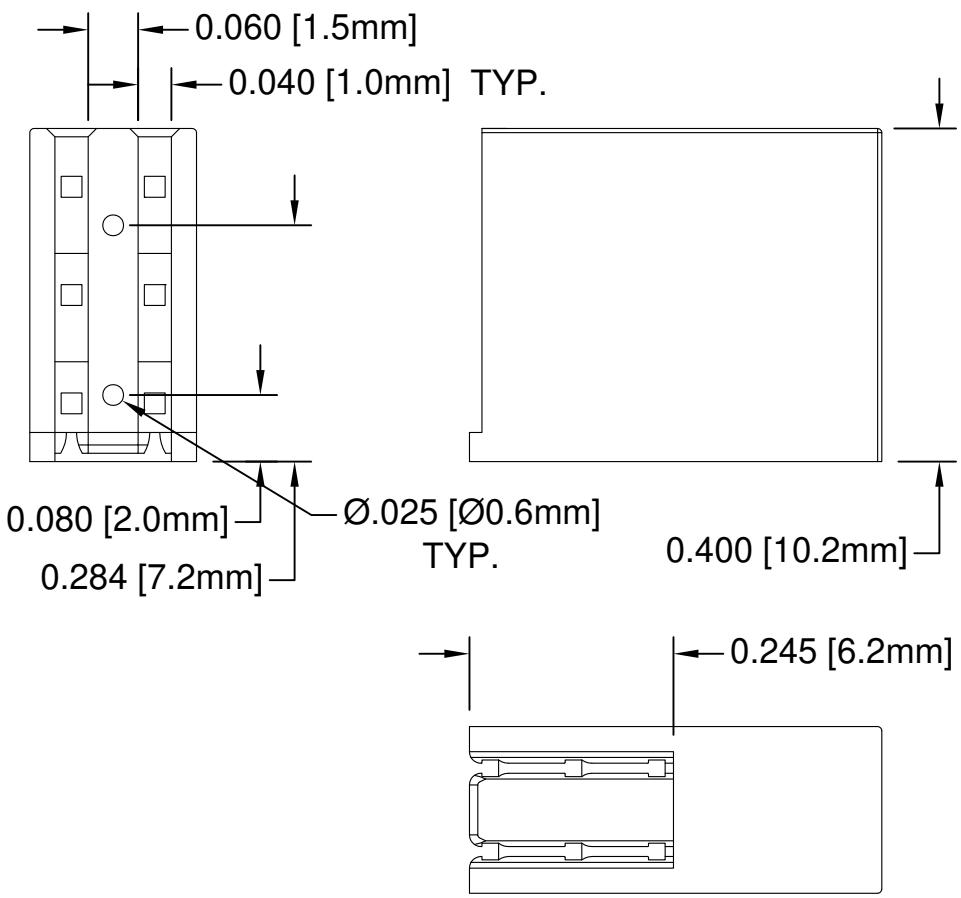
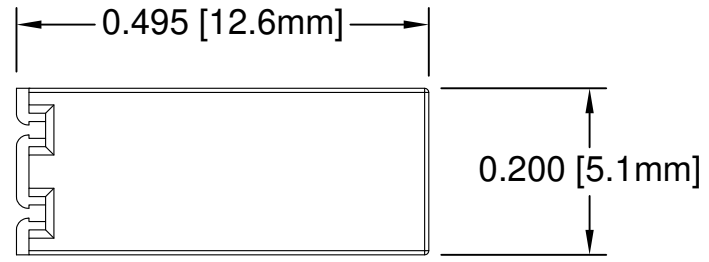
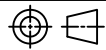

- 2. MATERIAL: NYLON 6/6, 94V-0, BLACK.
- 1. GENERAL SPECIFICATIONS: BIVAR MOLDED COMPONENT SPECIFICATION BV00-E101.

STANDARD TOLERANCE (UNLESS OTHERWISE SPECIFIED)		 BIVAR [®] 4 THOMAS, IRVINE, CA. 92618 TEL: (949) 951-8808 FAX: (949) 951-3974	
DECIMALS	ANGULAR		
.X ±.1	X° ± 1°	 TITLE: 3-HIGH HOLDER FOR 1.8mm LEDs	
.XX ±.01			
.XXX ±.005		DESIGNED: T. Yin	
DATE: 10/15/07		REVISION: D	
CHECKED: M. Chen		DATE: 10/15/07	
DESIGNED: T. Yin		DATE: 10/15/07	
CHECKED: M. Chen		DATE: 10/15/07	
DESIGNED: T. Yin		DATE: 10/15/07	
CHECKED: M. Chen		DATE: 10/15/07	
DESIGNED: T. Yin		DATE: 10/15/07	
CHECKED: M. Chen		DATE: 10/15/07	
DESIGNED: T. Yin		DATE: 10/15/07	
CHECKED: M. Chen		DATE: 10/15/07	
DESIGNED: T. Yin		DATE: 10/15/07	
CHECKED: M. Chen		DATE: 10/15/07	
DESIGNED: T. Yin		DATE: 10/15/07	
CHECKED: M. Chen		DATE: 10/15/07	
DESIGNED: T. Yin		DATE: 10/15/07	
CHECKED: M. Chen		DATE: 10/15/07	
DESIGNED: T. Yin		DATE: 10/15/07	
CHECKED: M. Chen		DATE: 10/15/07	
DESIGNED: T. Yin		DATE: 10/15/07	
CHECKED: M. Chen		DATE: 10/15/07	
DESIGNED: T. Yin		DATE: 10/15/07	
CHECKED: M. Chen		DATE: 10/15/07	
DESIGNED: T. Yin		DATE: 10/15/07	
CHECKED: M. Chen		DATE: 10/15/07	
DESIGNED: T. Yin		DATE: 10/15/07	
CHECKED: M. Chen		DATE: 10/15/07	
DESIGNED: T. Yin		DATE: 10/15/07	
CHECKED: M. Chen		DATE: 10/15/07	
DESIGNED: T. Yin		DATE: 10/15/07	
CHECKED: M. Chen		DATE: 10/15/07	
DESIGNED: T. Yin		DATE: 10/15/07	
CHECKED: M. Chen		DATE: 10/15/07	
DESIGNED: T. Yin		DATE: 10/15/07	
CHECKED: M. Chen		DATE: 10/15/07	
DESIGNED: T. Yin		DATE: 10/15/07	
CHECKED: M. Chen		DATE: 10/15/07	
DESIGNED: T. Yin		DATE: 10/15/07	
CHECKED: M. Chen		DATE: 10/15/07	
DESIGNED: T. Yin		DATE: 10/15/07	
CHECKED: M. Chen		DATE: 10/15/07	
DESIGNED: T. Yin		DATE: 10/15/07	
CHECKED: M. Chen		DATE: 10/15/07	
DESIGNED: T. Yin		DATE: 10/15/07	
CHECKED: M. Chen		DATE: 10/15/07	
DESIGNED: T. Yin		DATE: 10/15/07	
CHECKED: M. Chen		DATE: 10/15/07	
DESIGNED: T. Yin		DATE: 10/15/07	
CHECKED: M. Chen		DATE: 10/15/07	
DESIGNED: T. Yin		DATE: 10/15/07	
CHECKED: M. Chen		DATE: 10/15/07	
DESIGNED: T. Yin		DATE: 10/15/07	
CHECKED: M. Chen		DATE: 10/15/07	
DESIGNED: T. Yin		DATE: 10/15/07	
CHECKED: M. Chen		DATE: 10/15/07	
DESIGNED: T. Yin		DATE: 10/15/07	
CHECKED: M. Chen		DATE: 10/15/07	
DESIGNED: T. Yin		DATE: 10/15/07	
CHECKED: M. Chen		DATE: 10/15/07	
DESIGNED: T. Yin		DATE: 10/15/07	
CHECKED: M. Chen		DATE: 10/15/07	
DESIGNED: T. Yin		DATE: 10/15/07	
CHECKED: M. Chen		DATE: 10/15/07	
DESIGNED: T. Yin		DATE: 10/15/07	
CHECKED: M. Chen		DATE: 10/15/07	
DESIGNED: T. Yin		DATE: 10/15/07	
CHECKED: M. Chen		DATE: 10/15/07	
DESIGNED: T. Yin		DATE: 10/15/07	
CHECKED: M. Chen		DATE: 10/15/07	
DESIGNED: T. Yin		DATE: 10/15/07	
CHECKED: M. Chen		DATE: 10/15/07	
DESIGNED: T. Yin		DATE: 10/15/07	
CHECKED: M. Chen		DATE: 10/15/07	
DESIGNED: T. Yin		DATE: 10/15/07	
CHECKED: M. Chen		DATE: 10/15/07	
DESIGNED: T. Yin		DATE: 10/15/07	
CHECKED: M. Chen		DATE: 10/15/07	
DESIGNED: T. Yin		DATE: 10/15/07	
CHECKED: M. Chen		DATE: 10/15/07	
DESIGNED: T. Yin		DATE: 10/15/07	
CHECKED: M. Chen		DATE: 10/15/07	
DESIGNED: T. Yin		DATE: 10/15/07	
CHECKED: M. Chen		DATE: 10/15/07	
DESIGNED: T. Yin		DATE: 10/15/07	
CHECKED: M. Chen		DATE: 10/15/07	
DESIGNED: T. Yin		DATE: 10/15/07	
CHECKED: M. Chen		DATE: 10/15/07	
DESIGNED: T. Yin		DATE: 10/15/07	
CHECKED: M. Chen		DATE: 10/15/07	
DESIGNED: T. Yin		DATE: 10/15/07	
CHECKED: M. Chen		DATE: 10/15/07	
DESIGNED: T. Yin		DATE: 10/15/07	
CHECKED: M. Chen		DATE: 10/15/07	
DESIGNED: T. Yin		DATE: 10/15/07	
CHECKED: M. Chen		DATE: 10/15/07	
DESIGNED: T. Yin		DATE: 10/15/07	
CHECKED: M. Chen		DATE: 10/15/07	
DESIGNED: T. Yin		DATE: 10/15/07	
CHECKED: M. Chen		DATE: 10/15/07	
DESIGNED: T. Yin		DATE: 10/15/07	
CHECKED: M. Chen		DATE: 10/15/07	
DESIGNED: T. Yin		DATE: 10/15/07	
CHECKED: M. Chen		DATE: 10/15/07	
DESIGNED: T. Yin		DATE: 10/15/07	
CHECKED: M. Chen		DATE: 10/15/07	
DESIGNED: T. Yin		DATE: 10/15/07	
CHECKED: M. Chen		DATE: 10/15/07	
DESIGNED: T. Yin		DATE: 10/15/07	
CHECKED: M. Chen		DATE: 10/15/07	
DESIGNED: T. Yin		DATE: 10/15/07	
CHECKED: M. Chen		DATE: 10/15/07	
DESIGNED: T. Yin		DATE: 10/15/07	
CHECKED: M. Chen		DATE: 10/15/07	
DESIGNED: T. Yin		DATE: 10/15/07	
CHECKED: M. Chen		DATE: 10/15/07	
DESIGNED: T. Yin		DATE: 10/15/07	
CHECKED: M. Chen		DATE: 10/15/07	
DESIGNED: T. Yin		DATE: 10/15/07	
CHECKED: M. Chen		DATE: 10/15/07	
DESIGNED: T. Yin		DATE: 10/15/07	
CHECKED: M. Chen		DATE: 10/15/07	
DESIGNED: T. Yin		DATE: 10/15/07	
CHECKED: M. Chen		DATE: 10/15/07	
DESIGNED: T. Yin		DATE: 10/15/07	
CHECKED: M. Chen		DATE: 10/15/07	
DESIGNED: T. Yin		DATE: 10/15/07	
CHECKED: M. Chen		DATE: 10/15/07	
DESIGNED: T. Yin		DATE: 10/15/07	
CHECKED: M. Chen		DATE: 10/15/07	
DESIGNED: T. Yin		DATE: 10/15/07	
CHECKED: M. Chen		DATE: 10/15/07	
DESIGNED: T. Yin		DATE: 10/15/07	
CHECKED: M. Chen		DATE: 10/15/07	
DESIGNED: T. Yin		DATE: 10/15/07	
CHECKED: M. Chen		DATE: 10/15/07	
DESIGNED: T. Yin		DATE: 10/15/07	
CHECKED: M. Chen		DATE: 10/15/07	
DESIGNED: T. Yin		DATE: 10/15/07	
CHECKED: M. Chen		DATE: 10/15/07	
DESIGNED: T. Yin		DATE: 10/15/07	
CHECKED: M. Chen		DATE: 10/15/07	
DESIGNED: T. Yin		DATE: 10/15/07	
CHECKED: M. Chen		DATE: 10/15/07	
DESIGNED: T. Yin		DATE: 10/15/07	
CHECKED: M. Chen		DATE: 10/15/07	
DESIGNED: T. Yin		DATE: 10/15/07	
CHECKED: M. Chen		DATE: 10/15/07	
DESIGNED: T. Yin		DATE: 10/15/07	
CHECKED: M. Chen		DATE: 10/15/07	
DESIGNED: T. Yin		DATE: 10/15/07	
CHECKED: M. Chen		DATE: 10/15/07	
DESIGNED: T. Yin		DATE: 10/15/07	
CHECKED: M. Chen		DATE: 10/15/07	
DESIGNED: T. Yin		DATE: 10/15/07	
CHECKED: M. Chen		DATE: 10/15/07	
DESIGNED: T. Yin		DATE: 10/15/07	
CHECKED: M. Chen		DATE: 10/15/07	
DESIGNED: T. Yin		DATE: 10/15/07	
CHECKED: M. Chen		DATE: 10/15/07	
DESIGNED: T. Yin		DATE: 10/15/07	
CHECKED: M. Chen		DATE: 10/15/07	
DESIGNED: T. Yin		DATE: 10/15/07	
CHECKED: M. Chen		DATE: 10/15/07	
DESIGNED: T			