

## DESCRIPTION

Demonstration circuit 572 features the LTC1592, a 16-bit current output DAC with five software-selectable output ranges.

DC572 is a member of Linear Technology's QuickEval™ family of demonstration boards. It is designed to allow easy evaluation of the LTC1592 and may be connected directly to the target application's analog signals while using the DC590 USB Serial Controller board and supplied software to measure

performance. The exposed ground planes allow proper grounding to prototype circuitry. After evaluating with Linear Technology's software, the digital signals can be connected to the end application's processor / controller for development of the serial interface.

**Design files for this circuit board are available. Call the LTC factory.**

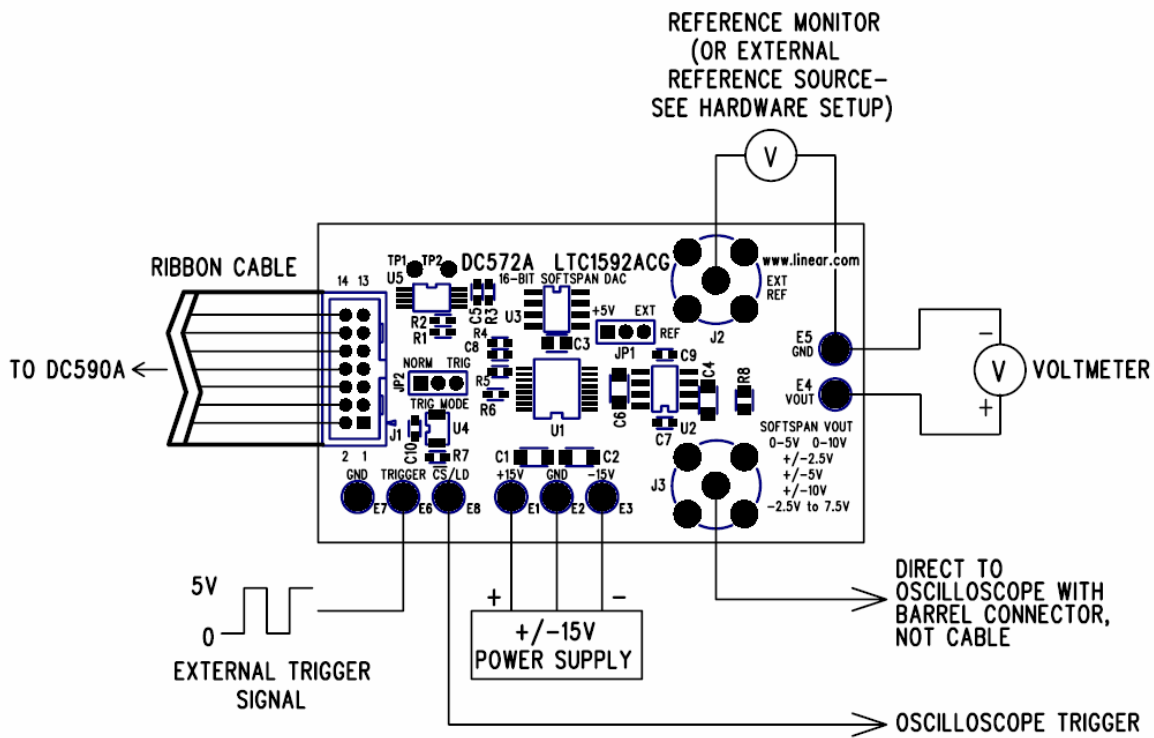

### QUICK START PROCEDURE

Connect a regulated, +/-15VDC power supply to the power connections on DC572. This must be done first because the +5V supply to the LTC1592 is derived from the +15V supply. Connect DC572 to a DC590 USB Serial Controller using the supplied 14 conductor ribbon cable. Connect DC590 to host PC with a standard USB A/B cable. Run the evaluation software supplied with DC590 or downloaded from

[www.linear.com](http://www.linear.com). The correct program will be loaded automatically.

By default, the control program will load a DC value into the LTC1592. The value may be changed by typing a voltage into the appropriate box, either in voltage, hexadecimal counts (0000 - FFFF), or decimal counts (0 – 65535) depending on the units selected.

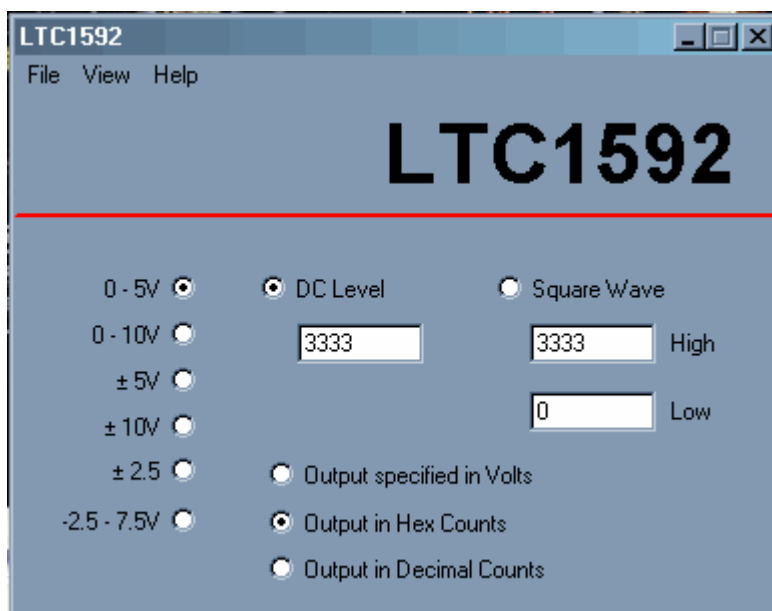

The other option is a square wave output. The frequency of the square wave is not tightly controlled; it is intended to allow measurement of settling time and glitch impulse.

Features may be periodically added to the software, see the software's help menu for the latest information.

## HARDWARE SET-UP

### POWER CONNECTIONS

A low-noise, +/-15V power supply must be connected to E1, E2, and E3 (+15V, Ground, and -15V, respectively.) This provides power to the LT1469 op amp and LT1236 reference. The LTC1592 power is taken from the reference output to minimize coupling of supply noise to the output.

### JUMPERS

JP1 – Select the source for REF+, either external or 5.00 volts from the onboard LT1236 reference (default.)

JP2 – Select normal or triggered mode. In normal mode, the LTC1592 is updated as fast as the controller can, which is dependant on the speed of the PC. In triggered mode, the update rate can be reduced by applying a 5V pulse to the TRIGGER turret.

### CONNECTION TO DC590 SERIAL CONTROLLER

J1 is the power and digital interface connector. Connect to DC590 serial controller with supplied 14 conductor ribbon cable.

### OUTPUT CONNECTIONS

The output voltage is connected to E4 (VOUT) and the center conductor of BNC connector J3. The BNC connector is intended for measuring settling time and glitch impulse by connecting directly to an oscilloscope input with a barrel connector. Do not use a long cable, as the output amplifier may not be stable.

### REFERENCE CONNECTIONS

The onboard LT1236 reference should be adequate for most applications. However, for multiplying mode applications an external reference signal may be applied to J2 (no connector is installed.)

## EXPERIMENTS

### OUTPUT VOLTAGE

The offset and gain errors of the LT1592 are relatively easy to measure. These errors are on the order of several LSBs, so a voltmeter with an accuracy of  $5V/2^{16} = 76\mu V$ , or 5 digits, is required. Note that errors are dependent on several factors, including reference error, amplifier offset, DAC errors, and errors in measurement equipment.

### OFFSET ERROR

Offset error is the output voltage when the digital code for zero output is loaded into the DAC. For the unipolar ranges (0-5V, 0-10V) the code for zero output is 0x0000. For the symmetric bipolar ranges

(+/-2.5V, +/-5V, +/-10V) it is 0x8000. For the -2.5 to +7.5V range, it is 0x4000.

### GAIN ERROR

Gain error is the error in slope of the DAC output, and is calculated by subtracting the zero code error from the maximum code error. For instance, in the -2.5 to 7.5V range a certain LTC1592 produces -2.50004V at zero code and +7.50009 at maximum code, the gain error is  $0.00009V - (-0.00004V) = 130\mu V$ .

The error in LSBs is  $130\mu V * 2^{16} / 10 = 0.85\text{LSB}$ .

### SETTLING TIME

To measure settling of the LTC1592, connect the output BNC to an oscilloscope input with a barrel connector (not a cable.) Be sure that the oscilloscope can tolerate the voltage that is being applied directly to the input. Select the Square wave output on the control panel, and enter the desired high and low voltages.

For large voltage swings, the oscilloscope can trigger directly on the analog output. For smaller

swings it may be useful to trigger on the  $\overline{CS}/LD$  turet. The rising edge of this signal initiates a transition on the DAC output.

Figures 1 through 4 show the full-scale step response of DC572 for various output ranges.

Scope Channel 4 is the analog output from the LT1469 amplifier and Channel 3 is the  $\overline{CS}/LD$  signal.

**Figure 1. 5V Step, 0-5V Range**

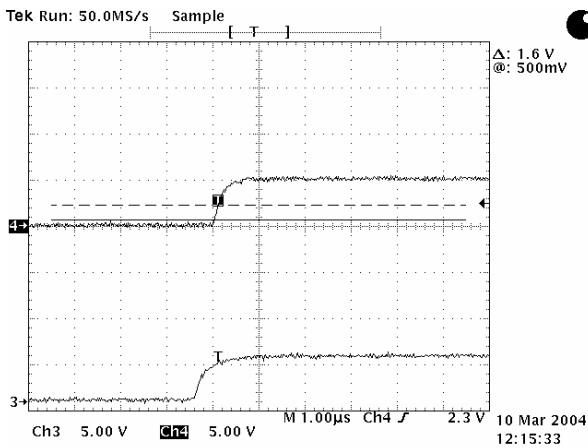

**Figure 2. -5V Step, 0-5V Range**

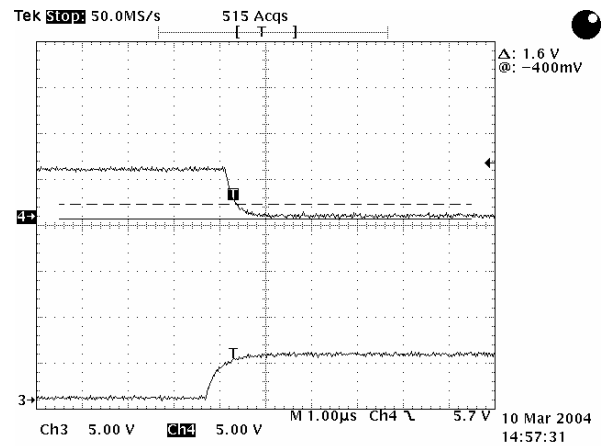

**Figure 3. 20V Step, +/-10V Range**

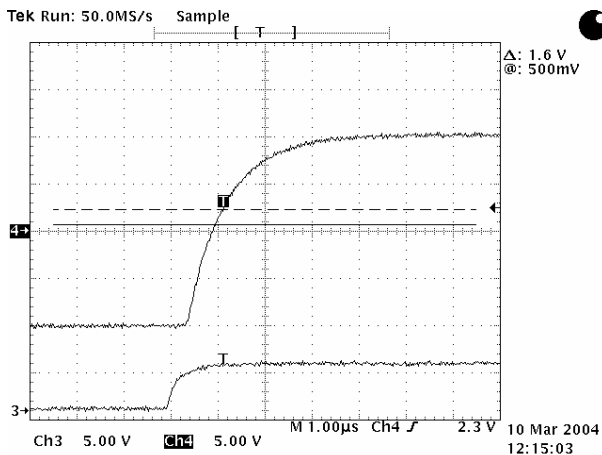

**Figure 4. -20V Step, +/-10V Range**

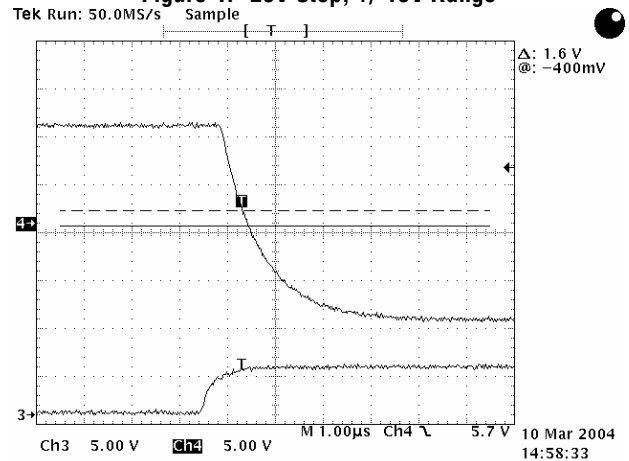

### GLITCH IMPULSE

Glitch impulse is the area in volt-seconds of the glitch produced when the DAC switches between two adjacent codes. Typically the glitch is largest when the DAC switches from 0x7FFF to 0x8000, as all of the DAC switches are changing state while the output is changing by 1 LSB. The LTC1592 has an internal deglitcher that reduces the midscale glitch impulse to less than 0.5 nV-s (typical.) Figure 5 shows the midscale glitch impulse of the LTC1592, configured as shown in the DC572 schematic (with

LT1469 output amplifier and a 30pF compensation capacitor.) The amplitude is approximately 2mV and the width is approximately 250nS, giving an area of 0.5nV-S.

This test is best performed by connecting the output BNC connector directly to the oscilloscope input with a barrel connector. Using a 10x probe may produce unpredictable results due to ground clip inductance.

**Figure 5. Glitch Impulse, +/-10V Range**

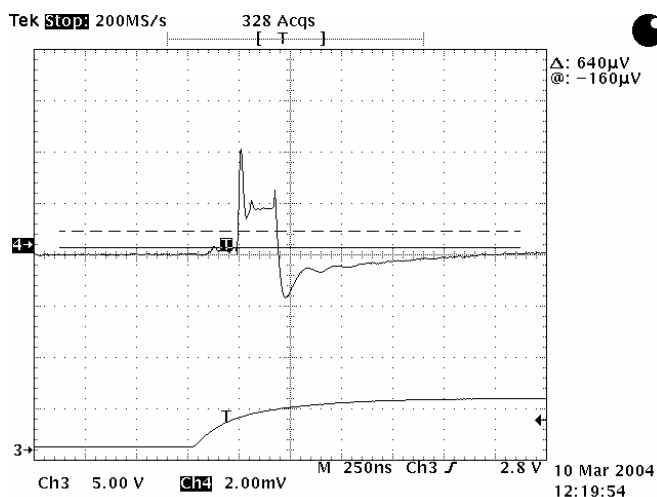

# QUICK START GUIDE FOR DEMONSTRATION CIRCUIT 572

## 16-BIT SOFTSPAN DAC

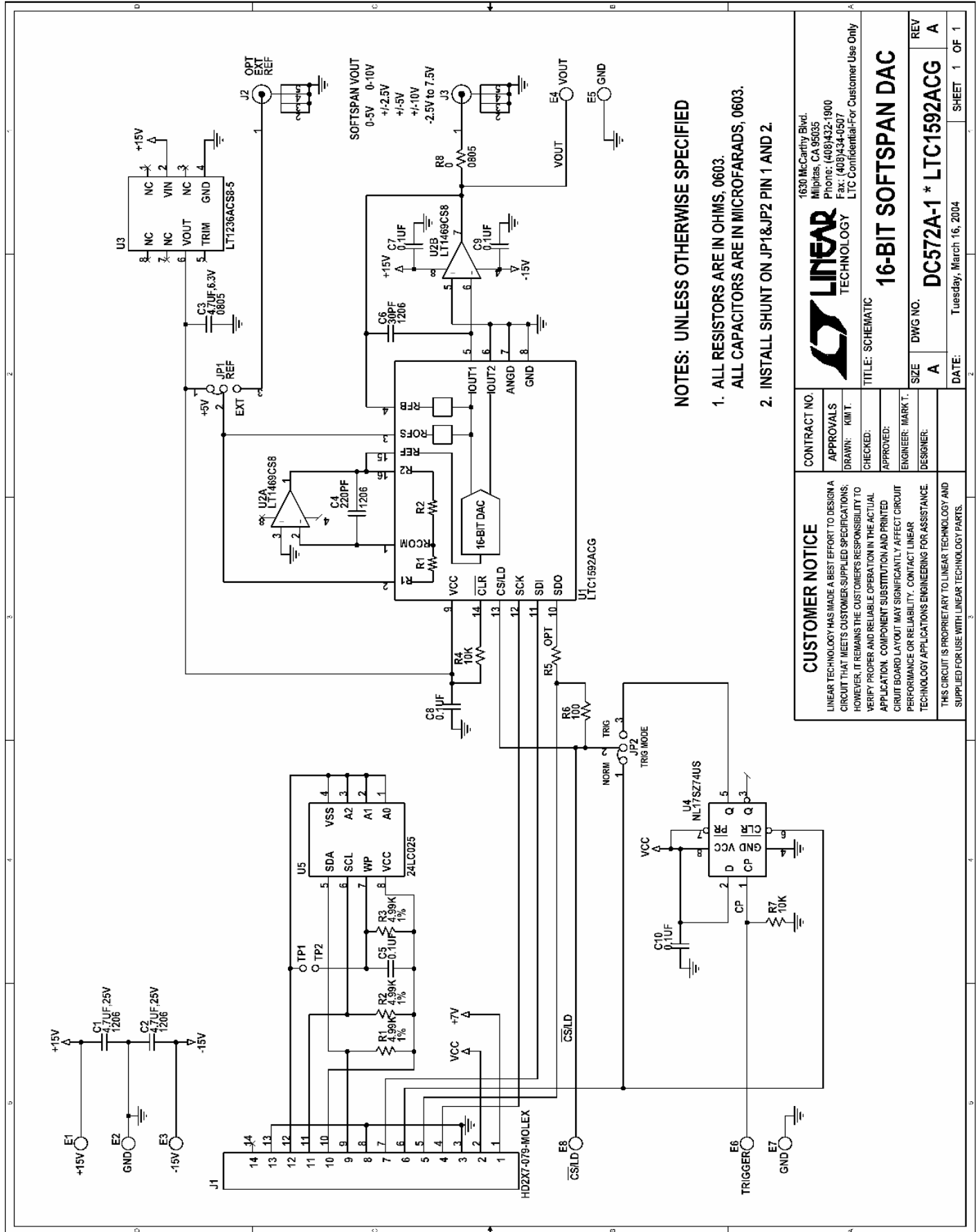

- NOTES: UNLESS OTHERWISE SPECIFIED**
1. ALL RESISTORS ARE IN OHMS, 0603.
  2. INSTALL SHUNT ON JP1&JP2 PIN 1 AND 2.

<b>CUSTOMER NOTICE</b>		<b>CONTRACT NO.</b>	
LINEAR TECHNOLOGY HAS MADE A BEST EFFORT TO DESIGN A CIRCUIT THAT MEETS CUSTOMER-SUPPLIED SPECIFICATIONS; HOWEVER, IT REMAINS THE CUSTOMER'S RESPONSIBILITY TO VERIFY PROPER AND RELIABLE OPERATION IN THE ACTUAL APPLICATION. COMPONENT SUBSTITUTION AND PRINTED CIRCUIT BOARD LAYOUT MAY SIGNIFICANTLY AFFECT CIRCUIT PERFORMANCE OR RELIABILITY. CONTACT LINEAR TECHNOLOGY APPLICATIONS ENGINEERING FOR ASSISTANCE.		APPROVALS	
THIS CIRCUIT IS PROPRIETARY TO LINEAR TECHNOLOGY AND SUPPLIED FOR USE WITH LINEAR TECHNOLOGY PARTS.		DRAWN: KIM T.	
		CHECKED:	
		APPROVED:	
		ENGINEER: MARK T.	
		DESIGNER:	
		DATE: Tuesday, March 16, 2004	
		SIZE DWG NO. A DC572A-1 * LTC1592ACG	
		TITLE: SCHEMATIC	
		REV A	
		SHEET 1 OF 1	

**LINEAR TECHNOLOGY**  
 1630 McCarthy Blvd.  
 Milpitas, CA 95035  
 Phone: (408)432-1900  
 Fax: (408)434-0507  
 LTC Confidential-For Customer Use Only