

PART NUMBER	REVISION	DESCRIPTION	FEED TYPE
2151981-1	E	FINE CRIMP HEIGHT ADJUST	MECHANICAL
2151981-2	E	FINE CRIMP HEIGHT ADJUST	PNEUMATIC
3-2151981-2	E	FINE CRIMP HEIGHT ADJUST	DOUBLE ACTING PNEUMATIC WITH SENSORS ⁸
5-2151981-1	E	SEAL STRIPPER CRIMPER TERMINATING UNIT	MECHANICAL
5-2151981-2	E	SEAL STRIPPER CRIMPER TERMINATING UNIT	PNEUMATIC
7-2151981-1	E	MECHANICAL AND CRIMP TOOLING KIT	MECHANICAL
7-2151981-2	E	PNEUMATIC AND CRIMP TOOLING KIT	PNEUMATIC
7-2151981-7	A	CRIMP TOOLING KIT	-

ATLANTIC VERSION TERMINATOR INTERFACE ADAPTER



APPLICATOR DATA		
CRIMP	SIZE	TYPE
WIRE	1.57 mm [.062]	F
INSUL	3.18 mm [.125]	O

APPLICATOR INSTRUCTIONS 408-35042

TERMINAL DATA: TE TERMINAL		TE CRIMP SPECIFICATION	
TERMINAL NAME: MCP 1.2 -CB RECEPTACLE			
WIRE STRIP LENGTH	INSULATION DIAMETER RANGE		
3.30-3.90 mm [.130-.154 IN]	Ø1.40-1.90 mm [.055-.075 IN]		
TERMINAL APPLICATION SPECIFICATION	114-18464		

TERMINALS APPLIED ⁶				SEAL INSULATION DIAMETER RANGE
TE TERMINAL	TE TERMINAL	TE SEAL	TE SEAL	
1670146-1	1670146-2			Ø0.9-1.3mm
1670146-3				Ø1.4-2.1mm
				2098582-1

WIRE SIZE	CRIMP HEIGHT mm [INCH]	CRIMP HEIGHT REFERENCE SETTING
0.75mm2	0.95 +/- 0.03 [.037 +/- .001]	7.2
0.5mm2 or 20AWG	0.84 +/- 0.03 [.033 +/- .001]	8.4

- ¹ RECOMMENDED SPARE PARTS
- ² REFER TO SUPPLIED INSTRUCTION SHEET FOR CLEANING, LUBRICATION & STORAGE OF APPLICATOR.
- ³ APPLY PART NUMBER 1-23419-5 LOCTITE TO THREADS OF ITEM 180. APPLY PART NUMBER 2-23419-6 LOCTITE TO THREADS OF ITEM 242.
- ⁴ CRIMP HEIGHT REFERENCE SETTING WAS THE SETTING USED WHEN THE APPLICATOR WAS QUALIFIED AT THE FACTORY. ADJUSTMENT MAY BE NECESSARY WHEN RUNNING APPLICATOR IN THE FIELD.
- ⁵ APPLY TORO-SEAL IN ALLEN SOCKET TO FILL HOLE AFTER FLAT HD HAS BEEN ADJUSTED TO CORRECT HEIGHT AT QUALIFICATION. APPLY #1-23419-5 LOC-TITE TO THREADS.
- ⁶ TERMINAL LUBRICANT IS RECOMMENDED.
- 7. UNLESS SPECIFIED OTHERWISE TORQUE VALUES SHALL BE USED PER DOCUMENT, 101-35000.
- ⁸ THIS APPLICATOR IS EQUIPPED WITH THE DOUBLE ACTING FEED WITH SENSORS AND IS APPLICATION SPECIFIC. IT DOES NOT REQUIRE ITEMS 49 & 248.

***WARNING**
ON INSTALLATION, SET WIRE DISC TO CRIMP HEIGHT REFERENCE SETTING FOR LARGEST WIRE SIZE. CRIMP HEIGHT REFERENCE SETTINGS GREATER THAN THE VALUE SHOWN MAY CAUSE DAMAGE TO THE CRIMP TOOLING, REFER TO THE INSTRUCTION SHEET FOR PROPER SETUP AND ADJUSTMENTS.

ATLANTIC VERSION
Shown on sheets 1 of 4 & 2 of 4
(Pacific version shown on sheets 3 of 4 & 4 of 4)

LOC	DIST	REVISIONS					
A	66	P	LTN	DESCRIPTION	DATE	OWN	APVD
		C		ECR-18-007874	23MAY2018	LG	JD
		D		ECR-21-007209	02AUG2021	AJ	YY
		D1		ADDED -32 AND -42	22MAR2023	ROY	CLT
		E		ECR-23-184231	15AUG2023	JWC	TE

-	-	-	1	1	-	-	-	1803515-3	RAM ASSEMBLY, SF ATLANTIC	293
-	-	-	1	1	-	-	-	2-1803583-1	APPLICATOR BASIC ASSEMBLY, SF	292
-	-	-	-	-	1	-	-	2844950-1	AIR FEED MODULE	290
-	1	-	1	-	-	1	-	2119641-1	FEED CAM, AIR FEED	248
-	1	1	1	1	1	1	1	2119082-9	CAM, SWAIL, INSULATION ADJUSTMENT	244
-	1	1	1	1	1	1	1	2079764-1	WASHER, WAVE SPRING, CREST-TO-CREST	243
-	1	1	1	1	1	1	1	2119083-1	RETAINER, INSULATION DIAL	242
-	1	1	1	1	1	1	1	7-18023-7	SCR, SKT HD CAP M3 X 4.0	241
-	-	1	-	1	-	-	1	2119580-1	MECHANICAL FEED ASSEMBLY	239
-	1	-	1	-	-	1	-	2844940-1	AIR FEED MODULE	238
-	-	-	1	1	-	-	-	4-1722335-3	STRIPPER, SIDE FEED	182
-	-	-	1	1	-	-	-	1-5018030-0	NUT, HEX, REG, RoHS, M3.5	181
-	-	-	1	1	-	-	-	1-1752354-8	STANDOFF, HOLD-DOWN	180
-	-	-	1	1	-	-	-	993111-1	PIN, SLOTTED SPRING 3.0 X 20.0	177
-	-	-	1	1	-	-	-	5-22280-0	SPRING, COMPRESSION	176
-	-	-	1	1	-	-	-	1752353-3	GUIDE PIN, HOLDDOWN	175
-	-	-	1	1	-	-	-	1901680-2	GUIDE PIN, HOLDDOWN	174
-	REF	REF	REF	REF	REF	REF	REF	994970-2	COUNTER, MAGNETIC	164
-	1	1	1	1	1	1	1	1-18028-2	WASHER, FLAT, REG M4	119
-	1	1	1	1	1	1	1	2844908-1	SCREW, LOCKING	99
-	1	1	1	1	1	1	1	2844907-1	POST, LOCKING	98
-	1	1	1	1	1	1	1	455888-4	SPACER, CRIMPER	82
-	1	1	1	1	1	1	1	1803607-3	DOCUMENTATION PACKAGE	71
-	1	1	1	1	1	1	1	2119740-1	TAG, IDENTIFICATION	67
-	2	2	2	2	2	2	2	2168078-1	SCREW, DRIVE, RH, RoHS, 2 x .188	66
-	1	1	1	1	1	1	1	2168083-2	SCR, SKT HD CAP, RoHS, M4 X 8.0	60
-	1	1	1	1	1	1	1	5-18022-5	SCR, HEX HD CAP, M4 X 6.0	59
-	1	1	1	1	1	1	1	985575-3	SCR, FLT SKT HD CAP M3 X 10.0	57
-	1	1	1	1	1	1	1	1338685-1	PAWL, FEED	56
-	4	4	4	4	4	4	4	2168083-3	SCR, SKT HD CAP, RoHS, M4 X 12.0	54
-	2	2	2	2	2	2	2	2168083-8	SCR, SKT HD CAP, RoHS, M4 X 16	53
-	1	1	1	1	1	1	1	5018030-1	NUT, HEX, REG, RoHS, M3	52
-	1	1	1	1	1	1	1	811242-5	BUMPER, HOLD DOWN	51
-	1	1	1	1	1	1	1	690753-2	SPACER, TONKER	50
-	1	2	1	2	-	1	2	18023-9	SCR, SKT HD CAP M4 X 6.0	49
-	-	1	-	1	-	-	1	2119652-1	FEED CAM, PRE FEED	48
-	-	1	-	1	-	-	1	2119653-1	FEED CAM, POST FEED	47
-	1	1	-	-	1	1	1	1803583-9	APPLICATOR BASIC ASSEMBLY, SF	46
-	1	1	-	-	1	1	1	1803515-1	RAM ASSEMBLY, SF ATLANTIC	44
-	1	1	1	1	1	1	1	1803602-1	SCR, BHSC, RoHS (M8 X 25)	41
-	1	1	1	1	1	1	1	3-1752356-3	SUPPORT, TERMINAL	34
-	2	2	2	2	2	2	2	2079383-5	SCR, BHSC, RoHS (M4 X 20)	33
-	2	2	2	2	2	2	2	2-2844962-8	SPACER, CYLINDRICAL, STRIP GUIDE	30
-	1	1	1	1	1	1	1	2844992-2	ASSEMBLY, STRIP GUIDE	29
-	1	1	1	1	1	1	1	455888-3	SPACER, CRIMPER	28
-	1	1	1	1	1	1	1	1320928-2	STRIP GUIDE	24
-	1	1	-	-	1	1	1	2168083-2	SCR, SKT HD CAP, RoHS, M4 X 8.0	21
-	2	2	1	1	2	2	2	1-18028-2	WASHER, FLAT, REG M4	20
-	1	1	-	-	1	1	1	2119533-1	STRIPPER, SIDE FEED	19
-	1	1	1	1	1	1	1	2119806-1	INSERT, SHEAR	13
-	1	1	1	1	1	1	1	3-22280-3	SPRING, COMPRESSION	12
-	1	1	1	1	1	1	1	1-356885-4	STOP, SHEAR	11
-	1	1	1	1	1	1	1	2119805-1	SHEAR HOLDER, FRONT	10
-	1	1	1	1	1	1	1	318707-1	FLOATING SHEAR, FRONT	9
-	1	2	2	1	1	1	1	4-1333202-8	ANVIL, COMBINATION	8
-	1	1	1	1	1	1	1	240641-1	SPACER	7
-	-	-	-	-	-	-	-	-	-	6
-	1	1	1	1	1	1	1	2119781-1	DEPRESSOR, SHEAR	5
-	1	1	1	1	1	1	1	238011-4	BLOCK, CRIMPER SPACER	4
-	1	2	2	1	1	1	1	1633965-1	CRIMPER, INSULATION O PREMIUM	3
-	1	1	1	1	1	1	1	455888-7	SPACER, CRIMPER	2
-	1	2	2	1	1	1	1	1-1752057-8	CRIMPER, WIRE PREMIUM, STEPPED	1

DIMENSIONS:		TOLERANCES UNLESS OTHERWISE SPECIFIED:		MATERIAL:		FINISH:	
mm	0 PLC ±	1 PLC ±	2 PLC ±	3 PLC ±	4 PLC ±	ANGLES	FINISH

OWN	C. CHEN	18JUN2013	NAME	Ocean Side Feed Applicator		
CHK	U. GUO	18JUN2013				
APVD	J. CRUZ	18JUN2013	SIZE	CAGE CODE	DRAWING NO	RESTRICTED TO
			A1	00779	2151981	
Customer Accessible Production Drawing			SCALE	1:2	SHEET	1 of 4
			REV	E		

LOC	DIST	REVISIONS					
A	66	P	LTN	DESCRIPTION	DATE	DWN	APVD
		-		SEE SHEET 1	-	-	-

FEED TYPE MECHANICAL

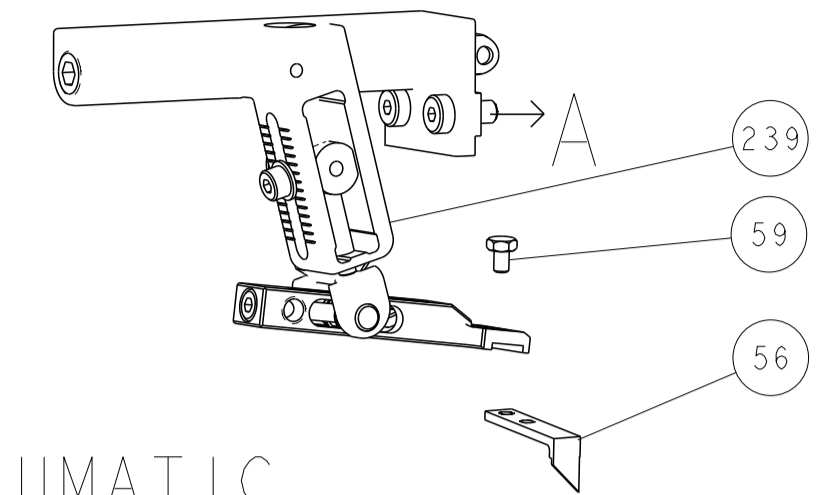

PNEUMATIC

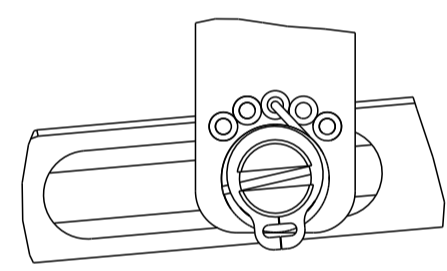
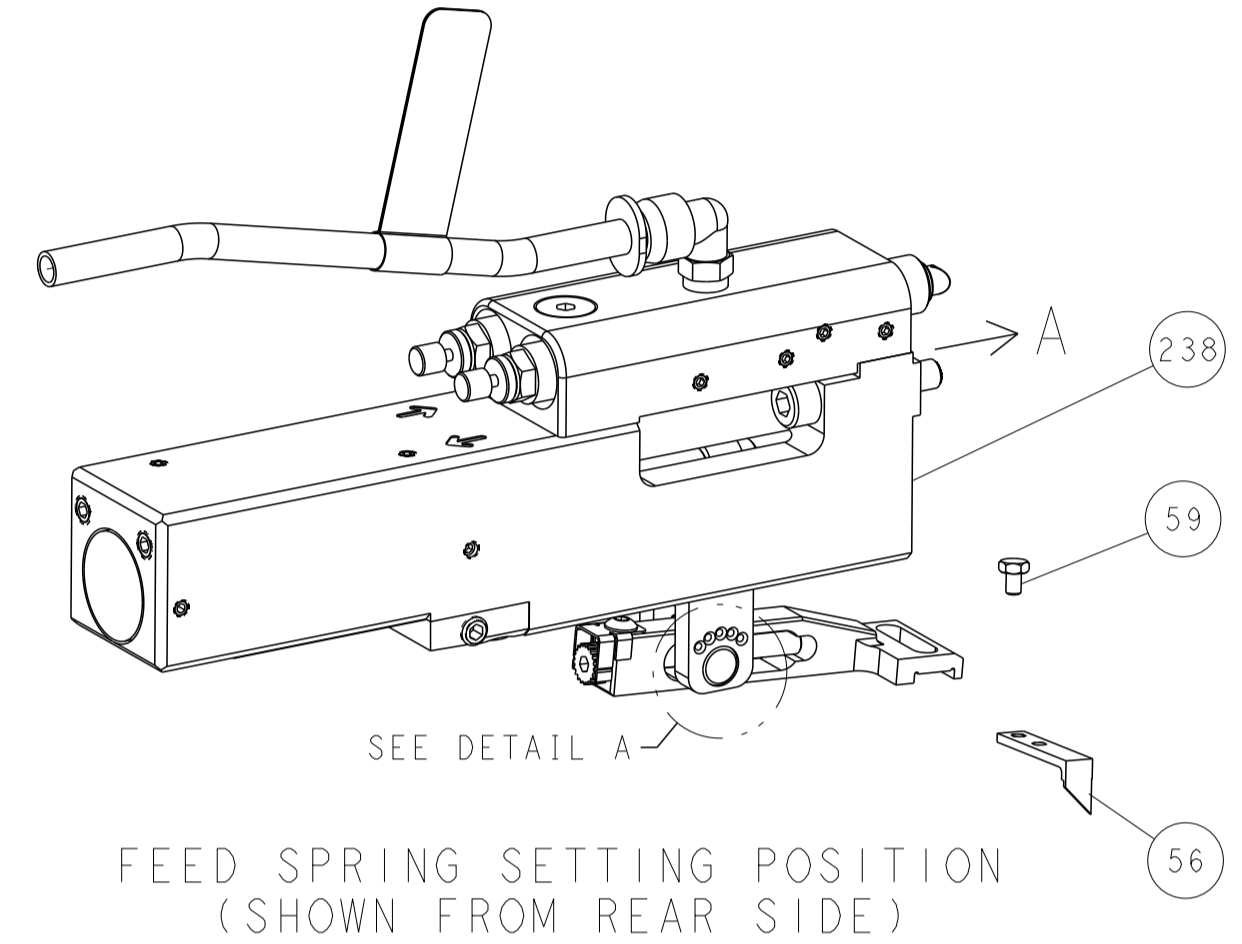

DETAIL A

DOUBLE ACTING PNEUMATIC WITH SENSORS

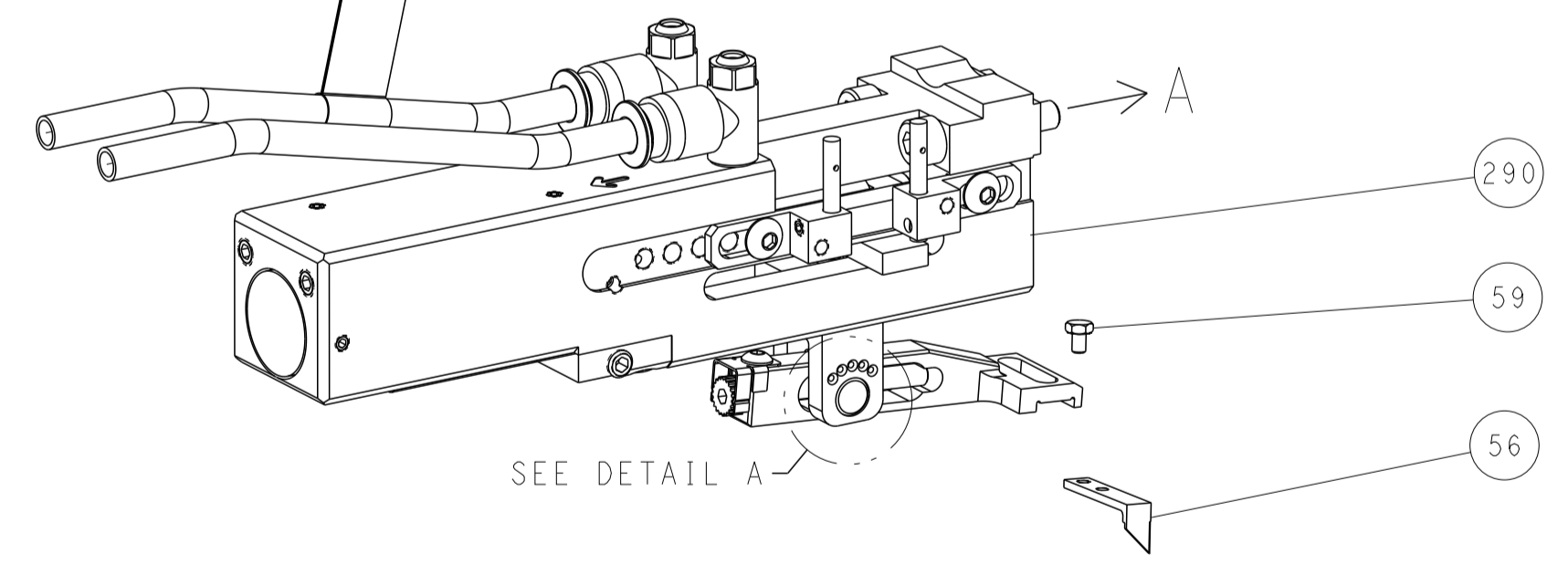

CAM POSITIONS

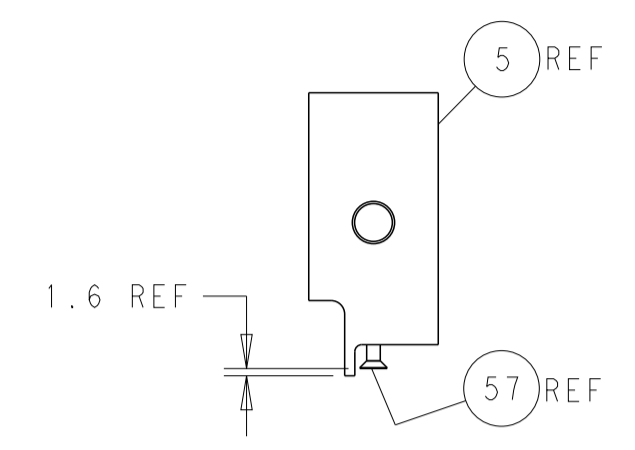
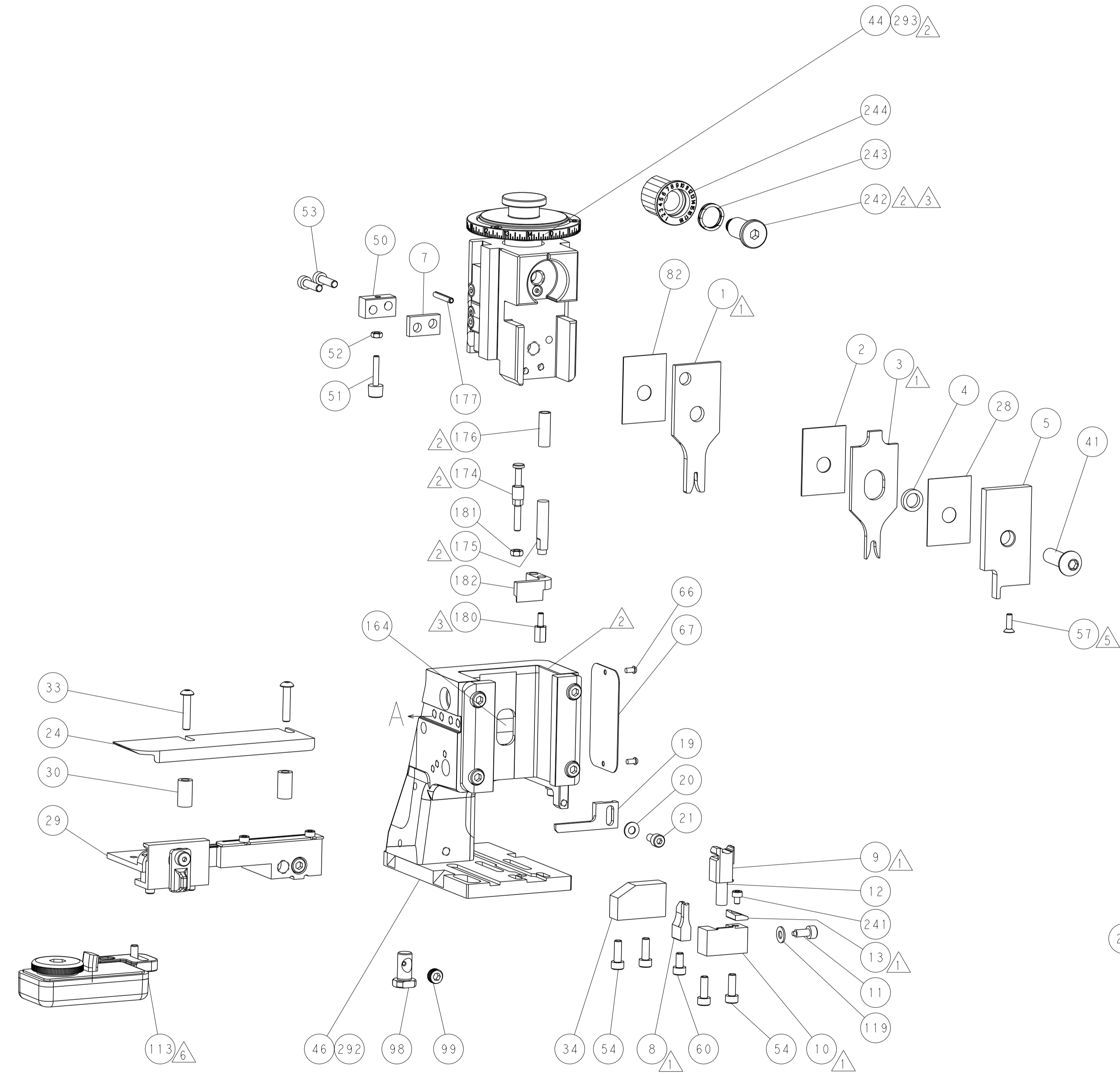
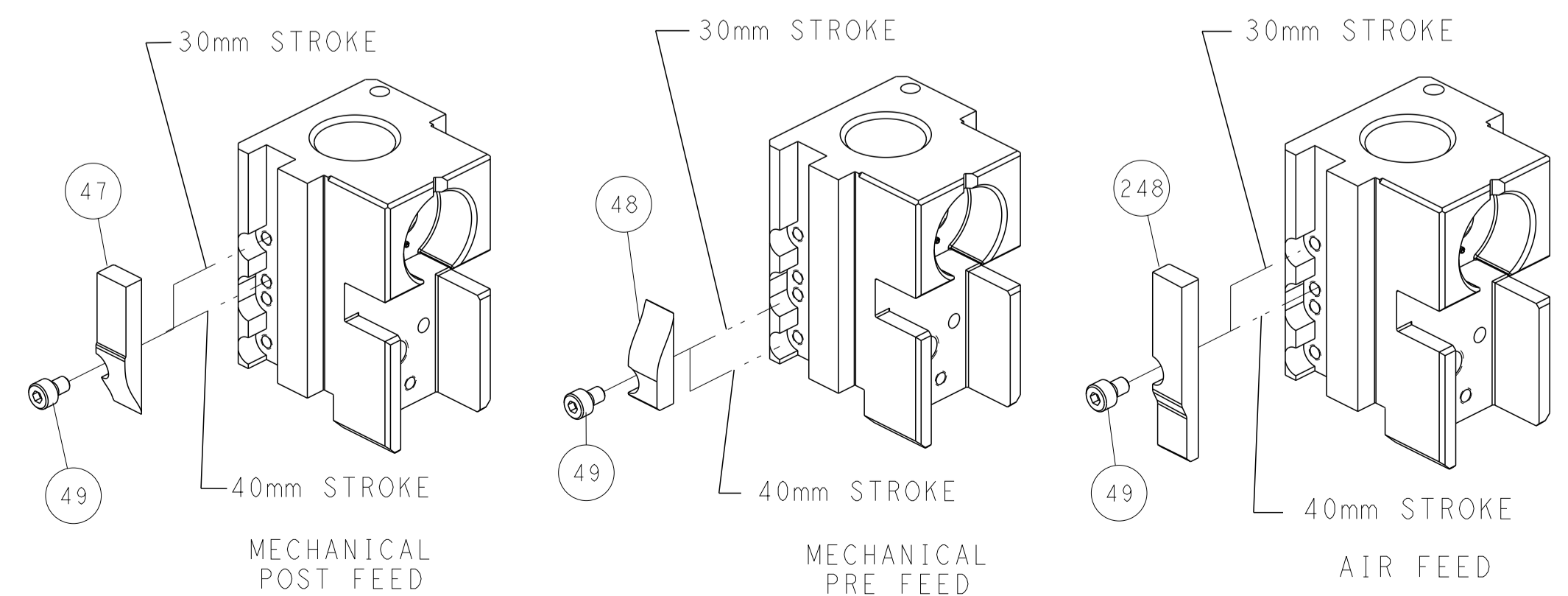

SHEAR DEPRESSOR DETAIL

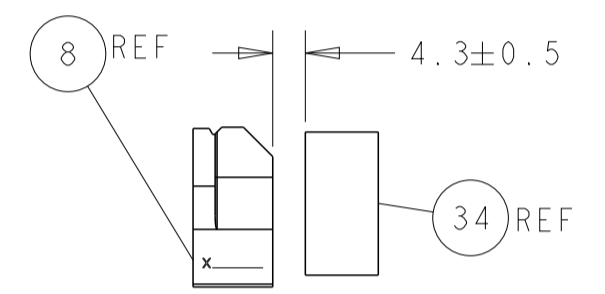

TERMINAL SUPPORT LOCATION

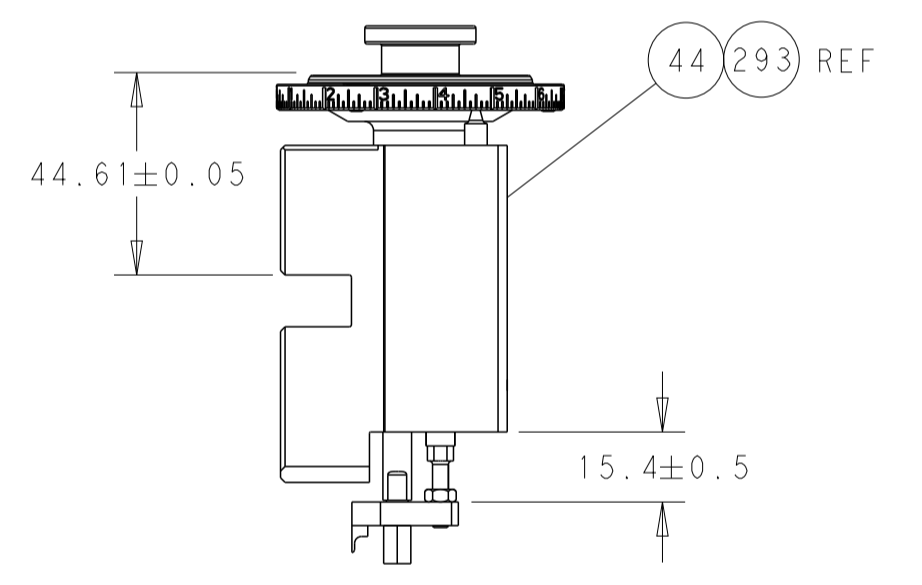

RAM AND HOLDDOWN SET-UP

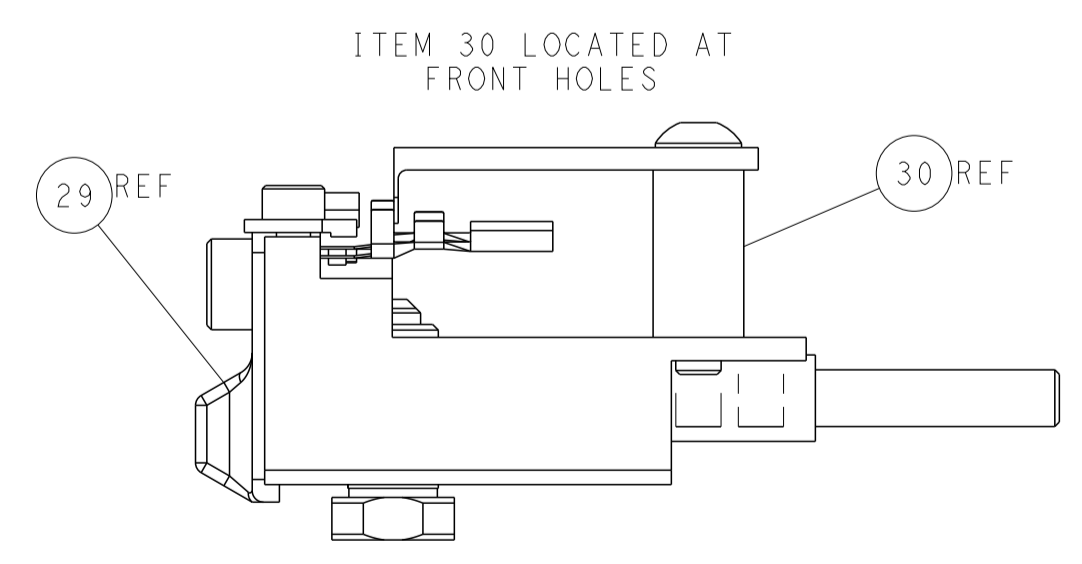

FEED TRACK POSITION GUIDE BY INSULATION BARREL

ATLANTIC VERSION
 Shown on sheets 1 of 4 & 2 of 4
 (Pacific version shown on sheets 3 of 4 & 4 of 4)

DIMENSIONS: mm 		TOLERANCES UNLESS OTHERWISE SPECIFIED: 0 PLC ± 1 PLC ± 2 PLC ± 3 PLC ± 4 PLC ± ANGLES ±		DWN C. CHEN 18JUN2013 CHK U. GUO 18JUN2013 APVD J. CRUZ 18JUN2013		TE Connectivity Harrisburg, PA 17105-3608	
MATERIAL:		FINISH:		NAME: Ocean Side Feed Applicator		SIZE: A1 CAGE CODE: 00779 DRAWING NO: C-2151981	
WEIGHT:		RESTRICTED TO:		SCALE: 1:2		SHEET 2 OF 4 REV E	

PART NUMBER	REVISION	DESCRIPTION	FEED TYPE
2-2151981-1	E	FINE CRIMP HEIGHT ADJUST	MECHANICAL
2-2151981-2	E	FINE CRIMP HEIGHT ADJUST	PNEUMATIC
4-2151981-2	E	FINE CRIMP HEIGHT ADJUST	DOUBLE ACTING PNEUMATIC WITH SENSORS ⁸
7-2151981-7	A	CRIMP TOOLING KIT	-

PACIFIC VERSION TERMINATOR INTERFACE ADAPTER



APPLICATOR DATA		
CRIMP	SIZE	TYPE
WIRE	1.57 mm [.062]	F
INSUL	3.18 mm [.125]	O
APPLICATOR INSTRUCTIONS 408-35042		

TERMINAL DATA: TE TERMINAL		TE CRIMP SPECIFICATION
TERMINAL NAME: MCP 1.2 -CB RECEPTACLE		
WIRE STRIP LENGTH 3.30-3.90 mm [1.30-.154 IN]		INSULATION DIAMETER RANGE Ø1.40-1.90 mm [.055-.075 IN]
TERMINAL APPLICATION SPECIFICATION 114-18464	-	-

TERMINALS APPLIED ⁶				
TE TERMINAL	TE TERMINAL	TE SEAL	TE SEAL	SEAL INSULATION DIAMETER RANGE
1670146-1	1670146-2		963142-2	Ø0.9-1.3mm
1670146-3			967067-1	Ø1.4-2.1mm
			2098582-1	Ø1.35-1.9mm

WIRE SIZE	CRIMP HEIGHT mm [INCH]	CRIMP HEIGHT REFERENCE SETTING
0.75mm ²	0.95 +/- 0.03 [.037 +/- .001]	7.2
0.5mm ² or 20AWG	0.84 +/- 0.03 [.033 +/- .001]	8.4

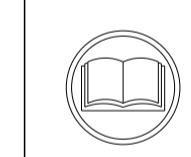

- ¹ RECOMMENDED SPARE PARTS
- ² REFER TO SUPPLIED INSTRUCTION SHEET FOR CLEANING, LUBRICATION & STORAGE OF APPLICATOR.
- ³ APPLY PART NUMBER 2-23419-6 LOCTITE TO THREADS OF ITEM 242.
- ⁴ CRIMP HEIGHT REFERENCE SETTING WAS THE SETTING USED WHEN THE APPLICATOR WAS QUALIFIED AT THE FACTORY. ADJUSTMENT MAY BE NECESSARY WHEN RUNNING APPLICATOR IN THE FIELD.
- ⁵ APPLY TORO-SEAL IN ALLEN SOCKET TO FILL HOLE AFTER FLAT HD HAS BEEN ADJUSTED TO CORRECT HEIGHT AT QUALIFICATION. APPLY #1-23419-5 LOC-TITE TO THREADS.
- ⁶ TERMINAL LUBRICANT IS RECOMMENDED.
- 7. UNLESS SPECIFIED OTHERWISE TORQUE VALUES SHALL BE USED PER DOCUMENT, 101-35000.
- ⁸ THIS APPLICATOR IS EQUIPPED WITH THE DOUBLE ACTING FEED WITH SENSORS AND IS APPLICATION SPECIFIC. IT DOES NOT REQUIRE ITEMS 49 & 151.

ENTRY LEVEL APPLICATOR		ITEM SUBSTITUTION LIST		
PART NUMBER	SAME AS	ITEM	ITEM DESCRIPTION	SUBSTITUTE PART NUMBER
8-2151981-1	2151981-1	1	WIRE CRIMPER	1-1803621-8
8-2151981-2	2151981-2	3	INSULATION CRIMPER	1803624-1
9-2151981-1	2-2151981-1	46	BASIC SUB -ASSEMBLY	1803940-9
9-2151981-2	2-2151981-2	141	BASIC SUB -ASSEMBLY	1-1803940-0
			LUBRICATOR	DELETE

***WARNING**
ON INSTALLATION, SET WIRE DISC TO CRIMP HEIGHT REFERENCE SETTING FOR LARGEST WIRE SIZE. CRIMP HEIGHT REFERENCE SETTINGS GREATER THAN THE VALUE SHOWN MAY CAUSE DAMAGE TO THE CRIMP TOOLING, REFER TO THE INSTRUCTION SHEET FOR PROPER SETUP AND ADJUSTMENTS.

PACIFIC VERSION
Shown on sheets 3 of 4 & 4 of 4
(Atlantic version shown on sheets 1 of 4 & 2 of 4)

LOC	DIST	REVISIONS					
A	66	P	LTN	DESCRIPTION	DATE	OWN	APVD
		-	-	SEE SHEET 1	-	-	-

-	1	-	-	2844950-1	AIR FEED MODULE	290	
-	1	1	1	2119082-9	CAM, SNAIL, INSULATION ADJUSTMENT	244	
-	1	1	1	2079764-1	WASHER, WAVE SPRING, CREST-TO-CREST	243	
³	-	1	1	2119083-1	RETAINER, INSULATION DIAL	242	
-	1	1	1	7-18023-7	SCR, SKT HD CAP M3 X 4.0	241	
-	-	-	1	2119580-1	MECHANICAL FEED ASSEMBLY	239	
-	-	1	-	2844940-1	AIR FEED MODULE	238	
-	REF	REF	REF	994970-2	COUNTER, MAGNETIC	164	
⁸	-	-	1	2119641-2	FEED CAM, AIR FEED	151	
-	1	1	1	2168083-8	SCR, SKT HD CAP, RoHS, M4 X 16	144	
-	4	4	4	2168083-9	SCR, SKT HD CAP, RoHS, M4 X 20	143	
-	-	-	1	2119653-2	FEED CAM, POST FEED	142	
-	1	1	1	1-1803583-0	APPLICATOR BASIC ASSEMBLY, SF	141	
-	1	1	1	1803516-1	RAM ASSEMBLY, SF PACIFIC	140	
-	1	1	1	1-18028-2	WASHER, FLAT, REG M4	119	
⁶	-	1	1	2119955-1	ASSY, LUBRICATOR, SIDE FEED	113	
-	1	1	1	2844908-1	SCREW, LOCKING	99	
-	1	1	1	2844907-1	POST, LOCKING	98	
-	1	1	1	455888-4	SPACER, CRIMPER	82	
-	1	1	1	1803607-3	DOCUMENTATION PACKAGE	71	
-	1	1	1	2119740-1	TAG, IDENTIFICATION	67	
-	2	2	2	2168078-1	SCREW, DRIVE, RH, RoHS, 2 x .188	66	
-	1	1	1	5-18022-5	SCR, HEX HD CAP, M4 X 6.0	59	
⁵	-	1	1	985575-3	SCR, FLT SKT HD CAP M3 X 10.0	57	
-	1	1	1	1338685-1	PAWL, FEED	56	
-	2	2	2	2168083-8	SCR, SKT HD CAP, RoHS, M4 X 16	53	
-	1	1	1	5018030-1	NUT, HEX, REG, RoHS, M3	52	
-	1	1	1	811242-5	BUMPER, HOLD DOWN	51	
-	1	1	1	690753-2	SPACER, TONKER	50	
⁸	-	-	1	2	18023-9	SCR, SKT HD CAP M4 X 6.0	49
-	-	-	1	2119652-1	FEED CAM, PRE FEED	48	
-	1	1	1	1803602-1	SCR, BHSC, RoHS (M8 X 25)	41	
-	1	1	1	3-1752356-3	SUPPORT, TERMINAL	34	
-	2	2	2	2079383-5	SCR, BHSC, RoHS (M4 X 20)	33	
-	2	2	2	2-2844962-8	SPACER, CYLINDRICAL, STRIP GUIDE	30	
-	1	1	1	2844992-2	ASSEMBLY, STRIP GUIDE	29	
-	1	1	1	455888-3	SPACER, CRIMPER	28	
-	1	1	1	1320928-2	STRIP GUIDE	24	
-	1	1	1	2168083-2	SCR, SKT HD CAP, RoHS, M4 X 8.0	21	
-	1	1	1	1-18028-2	WASHER, FLAT, REG M4	20	
-	1	1	1	2119533-1	STRIPPER, SIDE FEED	19	
¹	-	1	1	1	2119806-1	INSERT, SHEAR	13
-	1	1	1	3-22280-3	SPRING, COMPRESSION	12	
-	1	1	1	1-356885-4	STOP, SHEAR	11	
¹	-	1	1	1	2119805-1	SHEAR HOLDER, FRONT	10
¹	-	1	1	1	318707-1	FLOATING SHEAR, FRONT	9
¹	1	1	1	1	4-1333202-8	ANVIL, COMBINATION	8
-	1	1	1	1	240641-1	SPACER	7
-	-	-	-	-	-	6	
-	1	1	1	2119781-1	DEPRESSOR, SHEAR	5	
-	1	1	1	238011-4	BLOCK, CRIMPER SPACER	4	
¹	1	1	1	1	1633965-1	CRIMPER, INSULATION O PREMIUM	3
-	1	1	1	1	455888-7	SPACER, CRIMPER	2
¹	1	1	1	1	1-1752057-8	CRIMPER, WIRE PREMIUM, STEPPED	1

<small>THIS DRAWING IS CONTROLLED DOCUMENT. ANY CHANGES TO THIS DRAWING MUST BE APPROVED BY THE DESIGNATION SHOWN BY CONTACTING THE LATEST REVISION.</small>		DWN C. CHEN 18JUN2013 CHK U. GUO 18JUN2013 APVD J. CRUZ 18JUN2013	TE Connectivity Harrisburg, PA 17105-3608
DIMENSIONS: mm 	TOLERANCES UNLESS OTHERWISE SPECIFIED: 0 PLC ± 1 PLC ± 2 PLC ± 3 PLC ± 4 PLC ± ANGLES ± FINISH	NAME Ocean Side Feed Applicator SIZE CAGE CODE DRAWING NO A1 00779 C=2151981 WEIGHT SCALE 1:2 SHEET 3 OF 4 REV E	RESTRICTED TO Customer Accessible Production Drawing

LOC	DIST	REVISIONS					
A	66	P	LTN	DESCRIPTION	DATE	OWN	APVD
		-		SEE SHEET 1			

FEED TYPE MECHANICAL

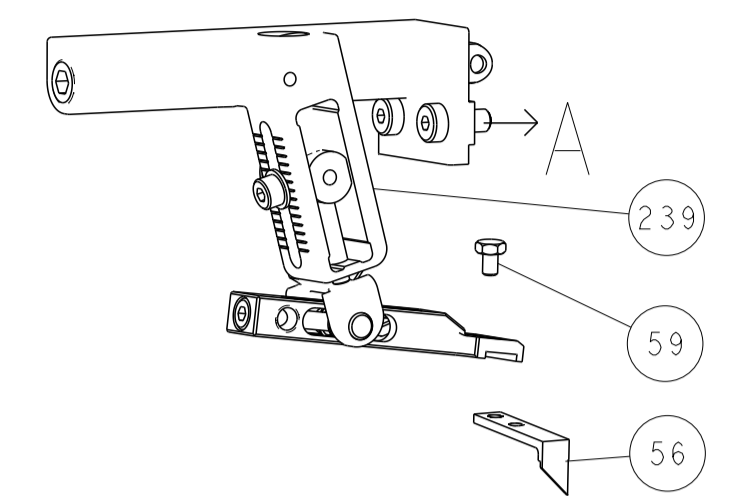

PNEUMATIC

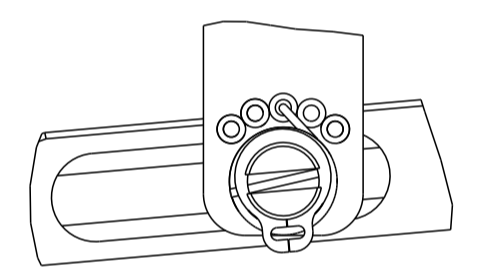
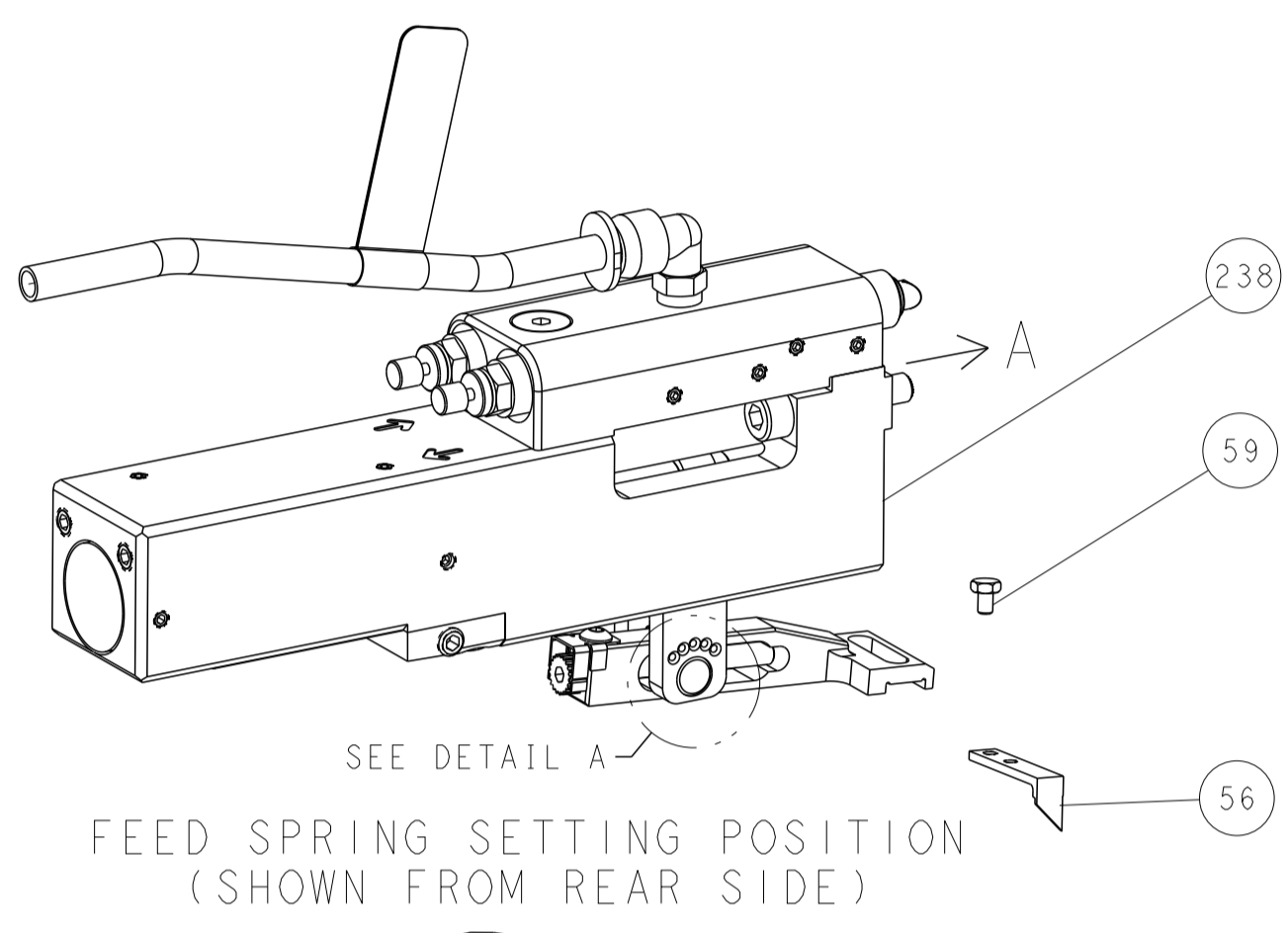

DOUBLE ACTING PNEUMATIC WITH SENSORS

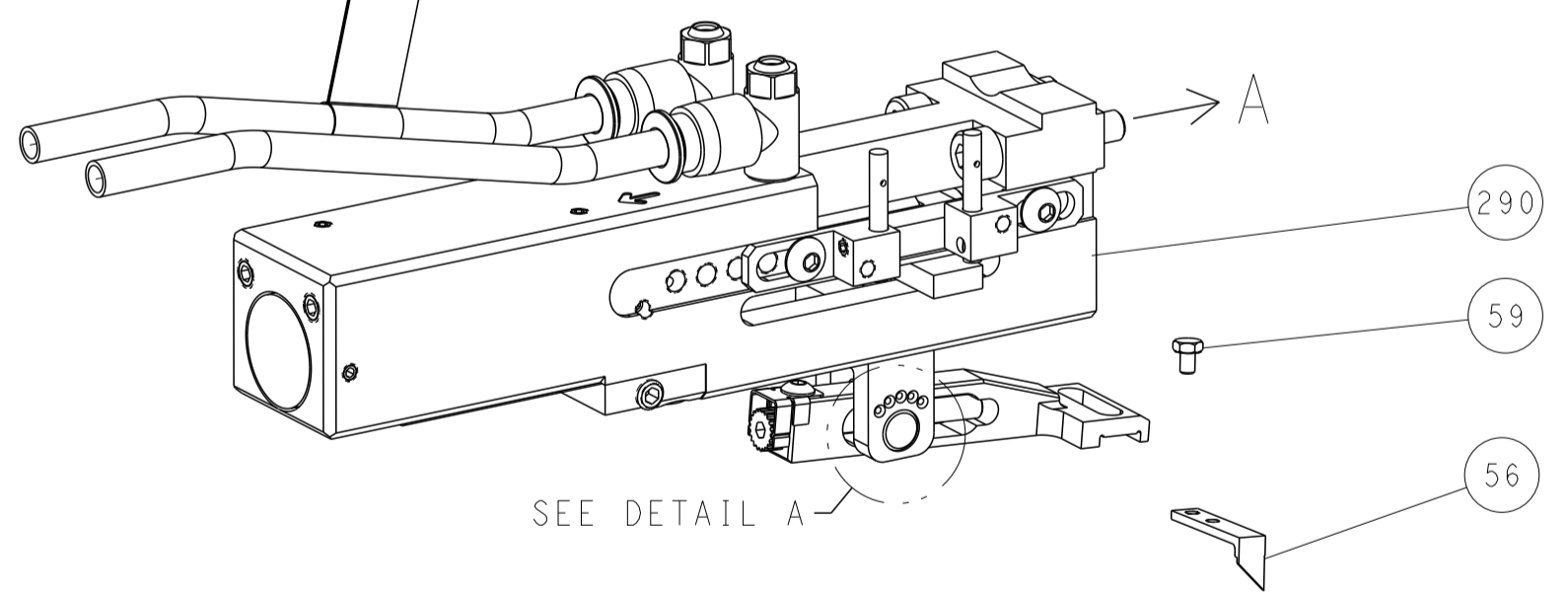

CAM POSITIONS

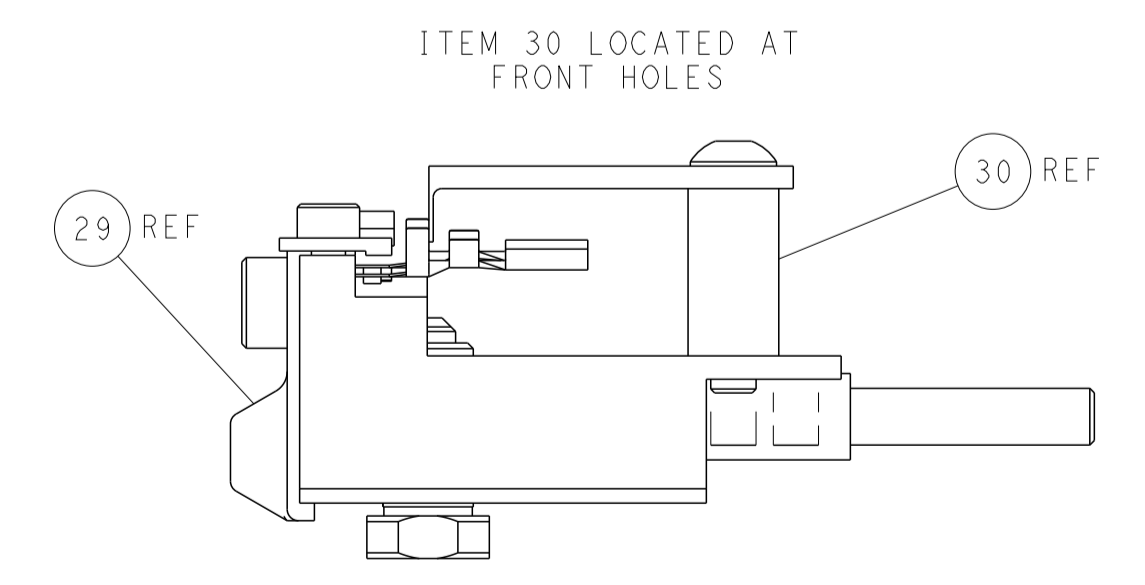
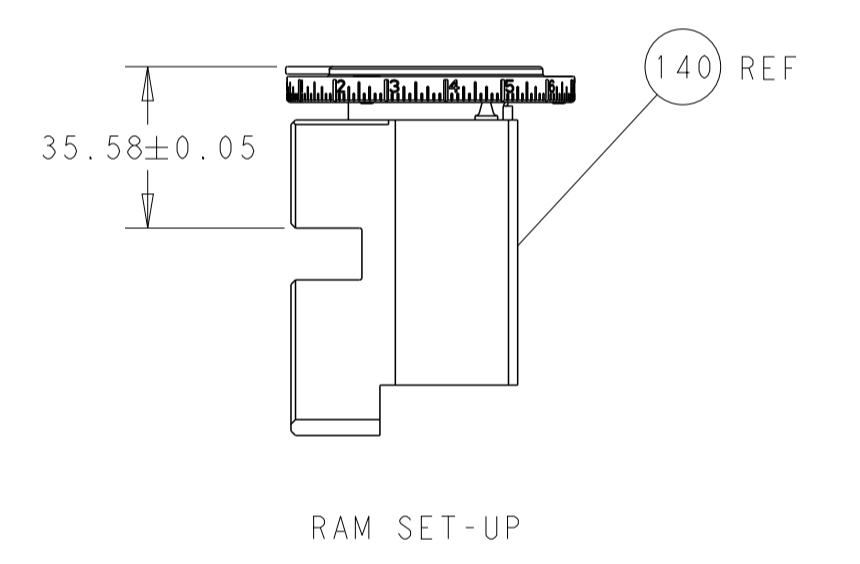
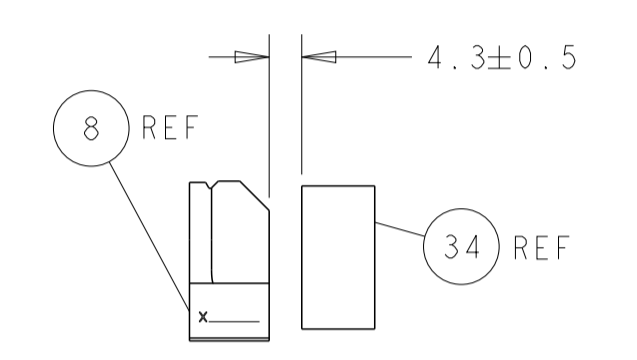
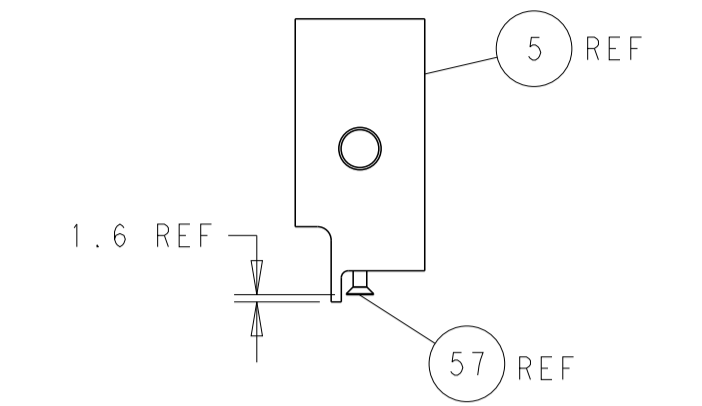
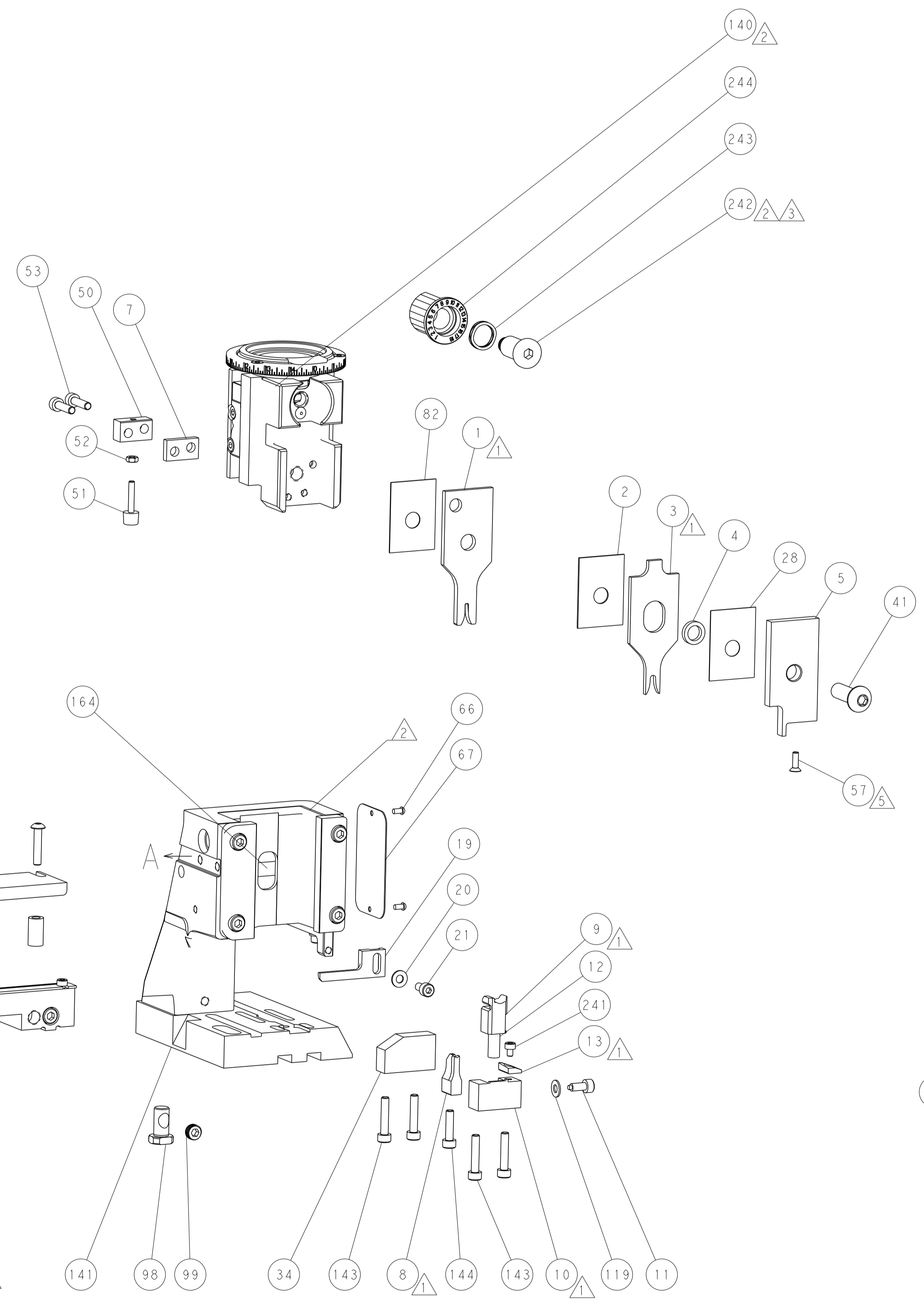
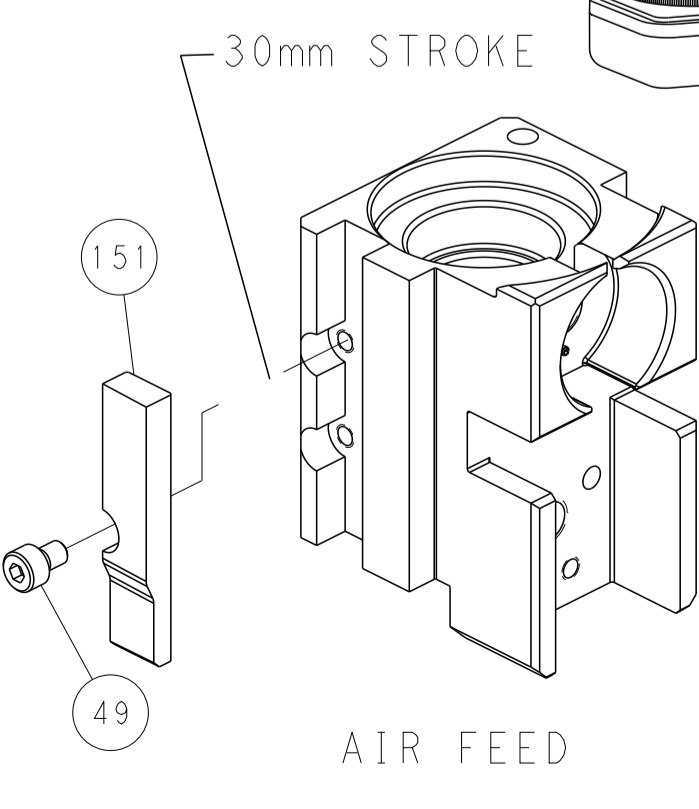
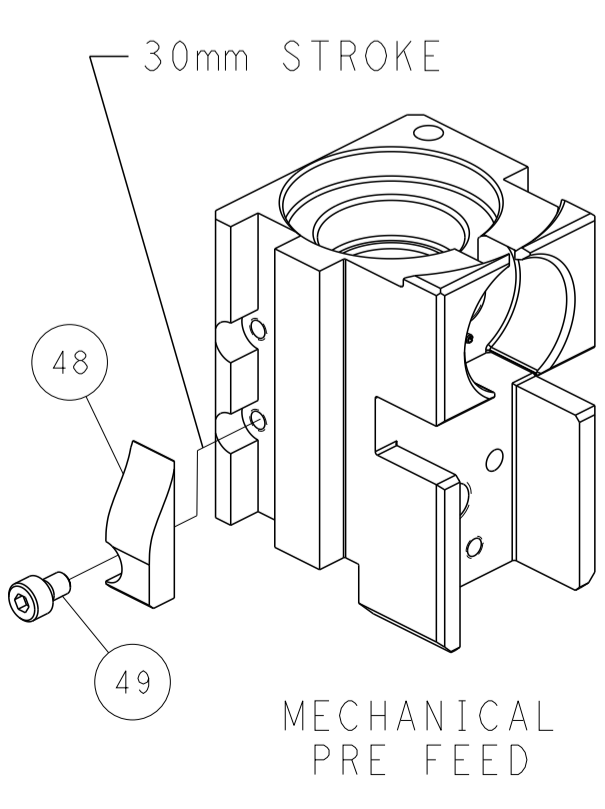
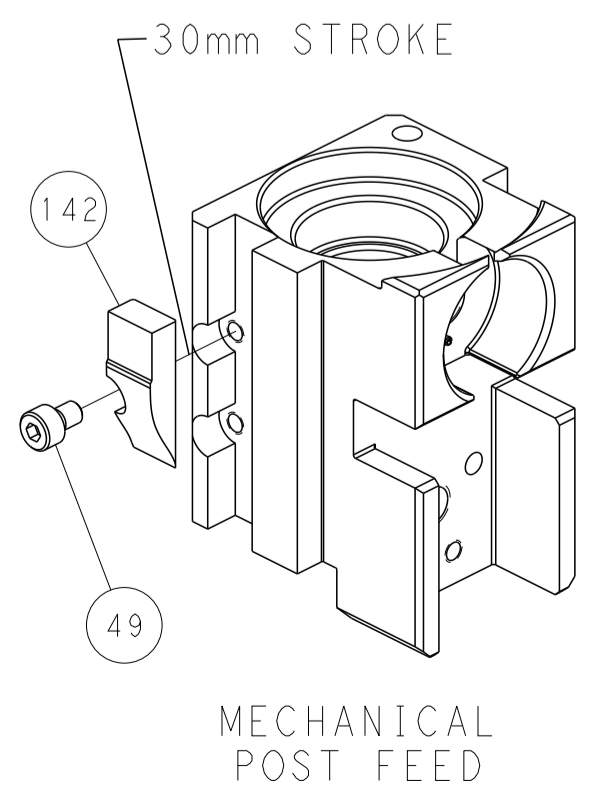

PACIFIC VERSION
 Shown on sheets 3 of 4 & 4 of 4
 (Atlantic version shown on sheets 1 of 4 & 2 of 4)

<small>THIS DRAWING IS UNPUBLISHED. RELEASED FOR PUBLICATION. ALL RIGHTS RESERVED. © 2013 BY TYCO ELECTRONICS CORPORATION. THIS DRAWING IS THE PROPERTY OF TYCO ELECTRONICS CORPORATION AND IS NOT TO BE REPRODUCED OR TRANSMITTED IN ANY FORM OR BY ANY MEANS, ELECTRONIC OR MECHANICAL, WITHOUT THE WRITTEN PERMISSION OF TYCO ELECTRONICS CORPORATION.</small>		DWN: C. CHEN 18JUN2013 CHK: U. GUO 18JUN2013 APVD: J. CRUZ 18JUN2013	TE Connectivity Harrisburg, PA 17105-3608
DIMENSIONS: mm TOLERANCES UNLESS OTHERWISE SPECIFIED: 0 PLC ± 1 PLC ± 2 PLC ± 3 PLC ± 4 PLC ± ANGLES FINISH		NAME: Ocean Side Feed Applicator APPLICATION SPEC:	SIZE: A1 CAGE CODE: 00779 DRAWING NO: 2151981 RESTRICTED TO:
MATERIAL:		WEIGHT:	SCALE: 1:2 SHEET: 4 OF 4 REV: E