

**SECTION A-A  
END VIEW**

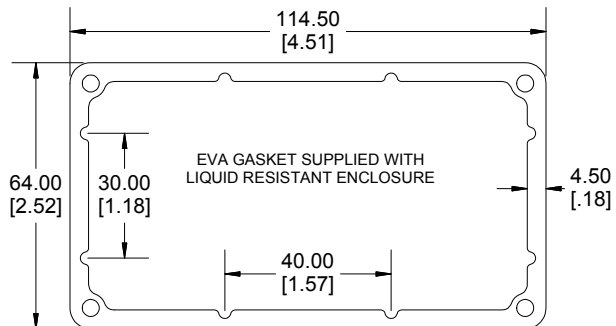

**SECTION B-B  
SIDE VIEW**

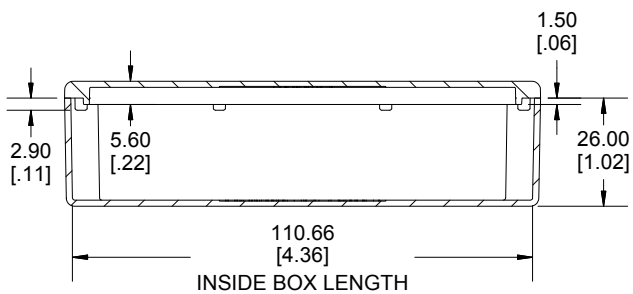
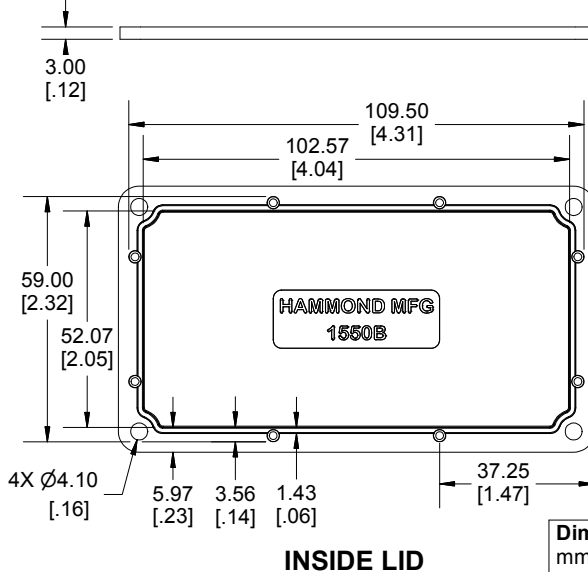
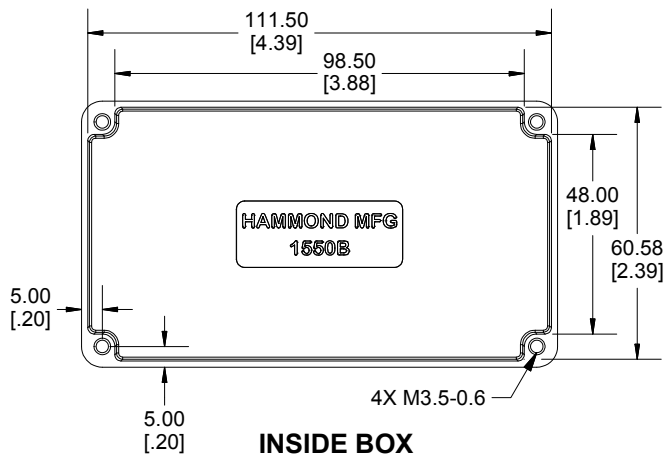

Enclosures can be Factory Modified ( Milling, Drilling, Printing etc.)  
Contact Factory [mjm@hammondmfg.com](mailto:mjm@hammondmfg.com) for quotes  
Solid models of this enclosure available in STEP or IGES.

<b>NOTE</b>	
Purchased assembly includes box, lid and 4 cover screws.	
Box and lid are made from Diecast Aluminum Alloy.	
EVA Gasket supplied with liquid resistant enclosure.	

<b>PART NUMBERS</b>	
<b>1550B Enclosure</b>	
Natural Finish Enclosure	1550B
Black Textured Enclosure	1550BBK
<b>1550B Liquid Resistant Enclosure (EVA Gasket)</b>	
Natural Finish Enclosure	1550WB
Black Textured Enclosure	1550WBBK
<b>ACCESSORIES</b>	
<b>Recommended Torque: 75 ozf.in / 55 cN.m</b>	
<b>Standard Cover Screws</b>	
Plated Cover Screws (Pkg 100) [M3.5-0.6 x 12mm]	1550MS100
Black Cover Screws (Pkg 100) [M3.5-0.6 x 12mm]	1550MS100BK
<b>Liquid Resistant Cover Screws and Gaskets</b>	
Stainless Steel Cover Screws (Pkg 100) [M3.5 x 12mm, With O-Ring]	1550WMS100
Black Stainless Steel Cover Screws (Pkg 100) [M3.5 x 12mm, With O-Ring]	1550WMS100BK
EVA Pre-formed Gasket Black	1550BEGASKET
Silicone Pre-formed Gasket Black	1550BSGASKET

**Dimensions:**  
mm  
[inches]

**HAMMOND  
MANUFACTURING®**

**1550B**

[www.hammondmfg.com](http://www.hammondmfg.com)