

DATE	REV	ECN	APP'D. BY
2-29-16	A6	10573	TRM
10-5-16	A7	10778	TRM

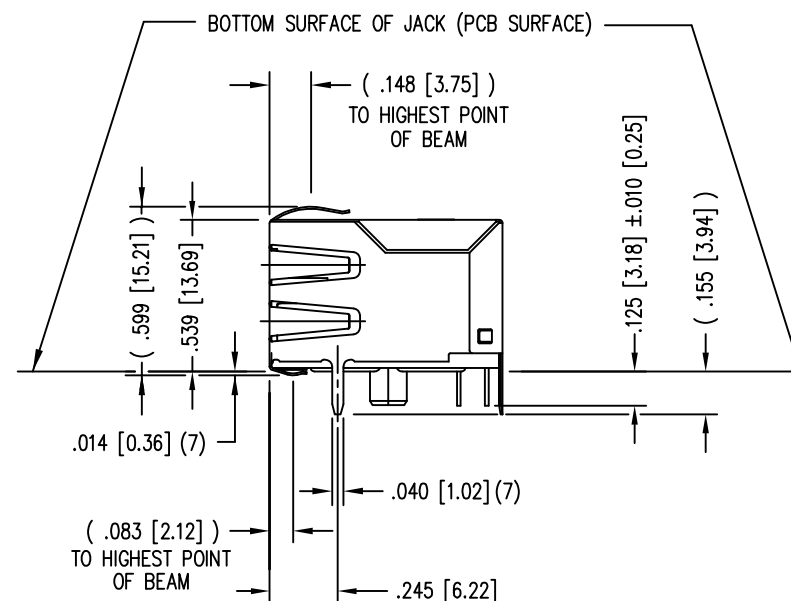

NOTES:

- CONNECTOR MATERIALS:  
HOUSING: THERMOPLASTIC UL94 V-0  
CONTACTS/SHIELD: COPPER ALLOY  
SHIELD PLATING: NICKEL OR TIN  
CONTACT PLATING: SELECTIVE GOLD IN CONTACT AREA  
SEE CHART FOR PART NUMBER
- FOR PRODUCT SPECIFICATIONS SEE PR022-01.
- DIMENSIONS AND TOLERANCES COMPLY WITH TIA-1096 STANDARD.
- THE SUGGESTED PANEL OPENING IS INTENDED TO GIVE USER THE ABILITY TO HAVE REASONABLE JACK/PANEL CLEARANCES, YET MAINTAIN GROUNDING CAPABILITY. THESE VARIABLES CAN BE ADJUSTED IN EITHER DIRECTION BUT MAY CARRY SOME CONSEQUENCES IN THE FORM OF LOWER MATING FORCES OR TIGHTER ASSEMBLY TOLERANCES.
- DESIGNED FOR CATEGORY 5/5e APPLICATIONS.

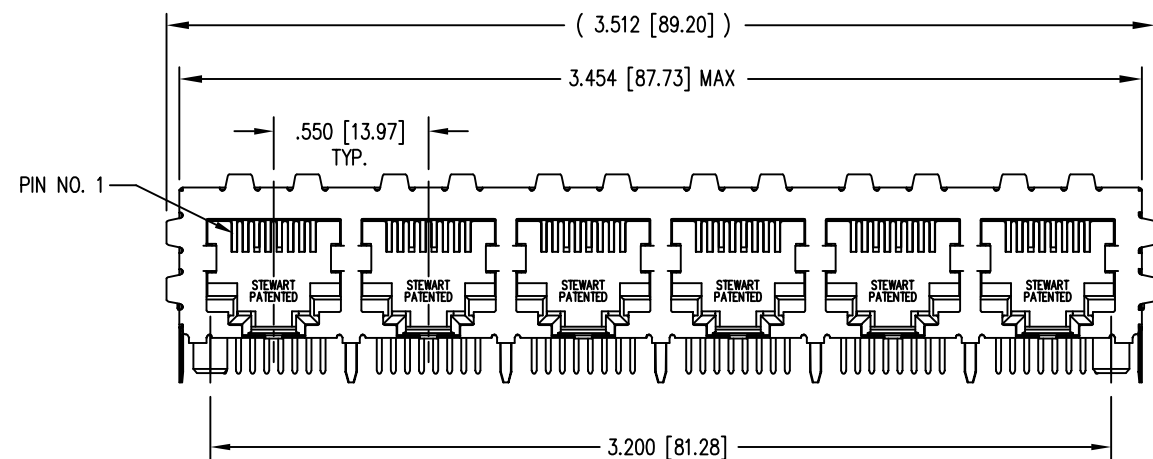
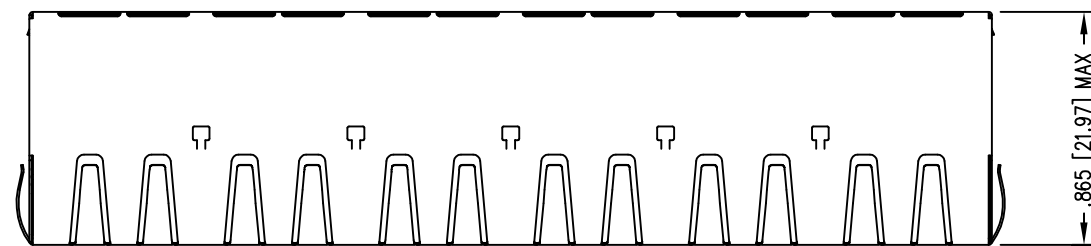
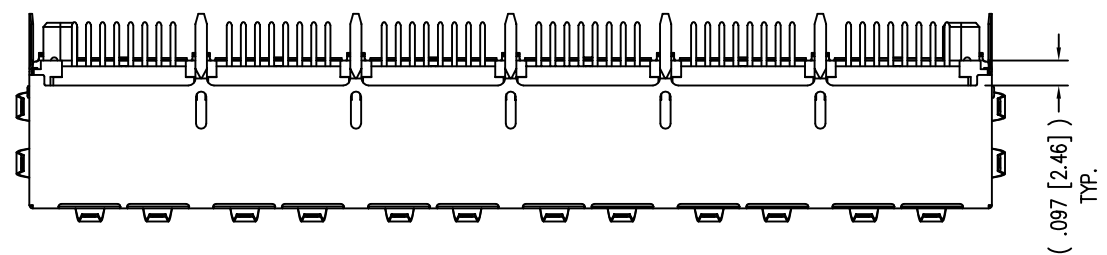
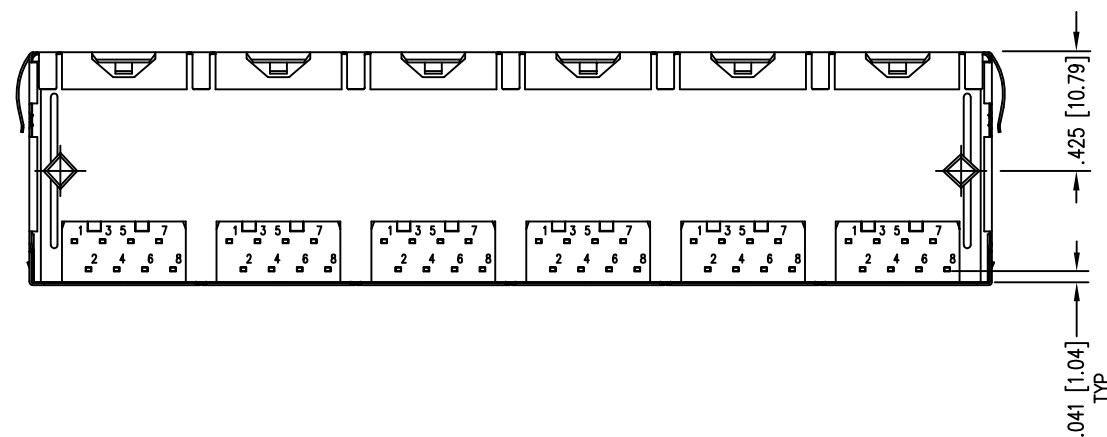

30 MICRO-INCHES [0.76um]	SS71800-049F
CONTACT PLATING IN MATING AREA	PART NUMBER

THIRD ANGLE PROJECTION

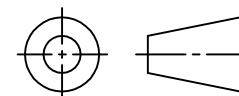

DO NOT SCALE DRAWING  
DRAWING IS SUBJECT TO  
CHANGE WITHOUT NOTICE

DIMENSIONS: INCHES [METRIC]  
UNLESS OTHERWISE SPECIFIED  
TOLERANCES ARE ±.005 [0.13]  
ANGLES ARE ± 1°

SHEET NO. 1 OF 2

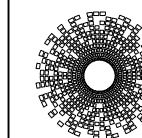

**stewart**  
CONNECTOR  
a bel group

1118 Susquehanna Trail South  
Glen Rock, PA 17327-9199  
(717) 235-7512

<http://www.stewartconnector.com>

TITLE: EMI-RFI ONE PIECE SHIELDED, ESD GROUNDED  
6 PORT PCB HARMONICA CAT 5/5e JACK PAC

THIS DRAWING AND THE SUBJECT MATTER SHOWN THEREON ARE CONFIDENTIAL AND THE PROPRIETARY PROPERTY OF STEWART CONNECTOR AND SHALL NOT BE REPRODUCED, COPIED, OR USED IN ANY MANNER WITHOUT PRIOR WRITTEN CONSENT OF STEWART CONNECTOR. ONE OR MORE U.S. PATENTS MAY APPLY TO THIS PRODUCT. FOR DETAILS, PLEASE VISIT: [HTTP://BELFUSE.COM/STEWART/STEWART\\_PATENTS/](http://BELFUSE.COM/STEWART/STEWART_PATENTS/)

DRN BY:	KRL	DATE	3/20/06
APPD BY:	TRM	DATE	3-21-06
DWG NO.	CT710046F	REV.	A7



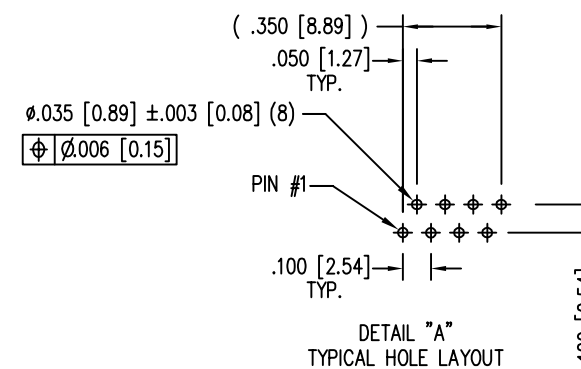
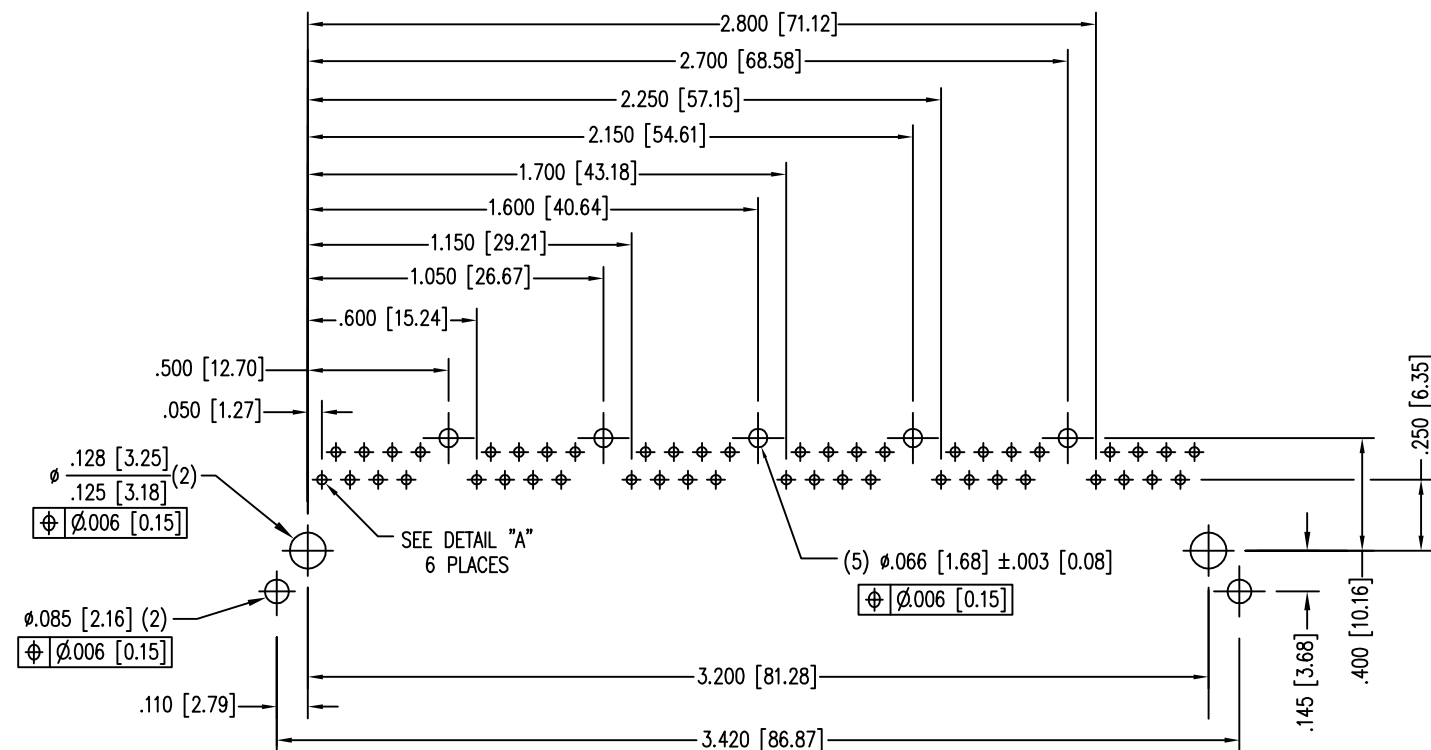

P.C.B. RECOMMENDED HOLE LAYOUT  
SEEN FROM COMPONENT SIDE  
ALL CENTERLINE DIMENSIONS ARE BASIC.

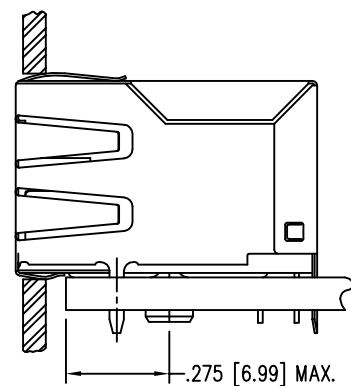
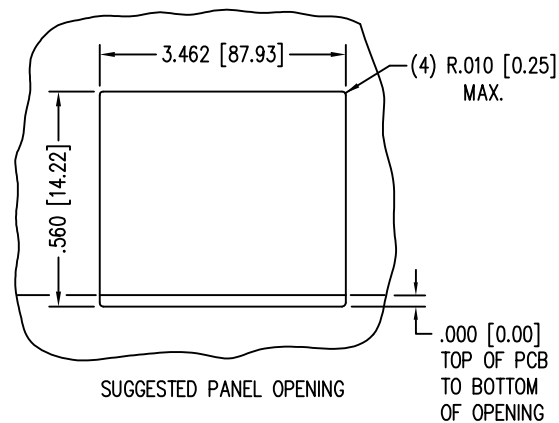

THIRD ANGLE PROJECTION		1118 Susquehanna Trail South Glen Rock, PA 17327-9199 (717) 235-7512 <a href="http://www.stewartconnector.com">http://www.stewartconnector.com</a>
DO NOT SCALE DRAWING DRAWING IS SUBJECT TO CHANGE WITHOUT NOTICE		
DIMENSIONS: INCHES [METRIC]	TITLE: EMI-RFI ONE PIECE SHIELDED, ESD GROUNDED 6 PORT PCB HARMONICA CAT 5 JACK PAC	
UNLESS OTHERWISE SPECIFIED TOLERANCES ARE ±.005 [0.13] ANGLES ARE ± 1°	THIS DRAWING AND THE SUBJECT MATTER SHOWN THEREON ARE CONFIDENTIAL AND THE PROPRIETARY PROPERTY OF STEWART CONNECTOR AND SHALL NOT BE REPRODUCED, COPIED, OR USED IN ANY MANNER WITHOUT PRIOR WRITTEN CONSENT OF STEWART CONNECTOR. ONE OR MORE U.S. PATENTS MAY APPLY TO THIS PRODUCT. FOR DETAILS, PLEASE VISIT: <a href="http://BELFUSE.COM/STEWART/STEWART_PATENTS/">HTTP://BELFUSE.COM/STEWART/STEWART_PATENTS/</a>	
SHEET NO. 2 OF 2	DRN BY: KRL APPD BY: TRM DWG NO. CT710046F	DATE 3/20/06 DATE 3-21-06 REV. A7