

Grove - Optocoupler Relay (M281).md

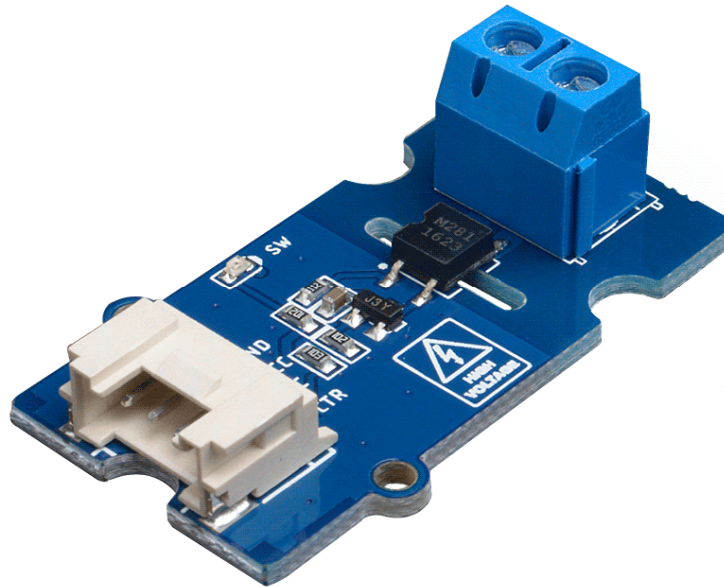

This module is a bi-directional SPSD(single-pole, single-throw), normally open solid state relay(SSR). The Grove Optocoupler Relay (M281) offers very low on-resistance, which allowing a high load current rating.

Unlike the other TRIAC SSR in our website, this relay is based on MOSFET, so it can carry both AC load and DC load. If you need to use a SSR with the DC load, this is what you want!

Features

- Low on-resistance(0.5Ω MAX.)
- 1A continuous load current
- 60V load voltage rating
- Low input control current(3mA TYP.)
- High input-to-output isolation(1.5kV MIN.)

Applications

- Automated Test Equipment
- Meter reading systems
- Medical equipment
- Battery monitoring
- Multiplexers

Specification

Parameter	Value
Supply voltage	3.3V / 5V
Operating temperature	-40 – 85°C
Storage temperature	- 55°C – 125°C
Blocking voltage	60 V
Continuous load current	1A
Leakage current	0.2 uA(TYP.) 1 uA(Max.)
On-Resistance	0.5 Ω(TYP.) 0.7 Ω(Max.)
Isolation resistance	100 GΩ
Turn-On time	1.4 ms(TYP.) 5 ms(Max.)
Turn-Off time	0.2 ms(TYP.) 2 ms(Max.)
Interface	Digital

Table 1. *General Specification*

Hardware Overview

Pinout



- 4** GND: connect this module to the system GND
- 3** VCC: you can use 5V or 3.3V for this module
- 2** NC: not connected
- 1** CTR: control signal, high-close/low open
- 5** Load Screw Interface, normally open

Figure 1. Pinout

Platforms Supported

Arduino	Raspberry Pi	BeagleBone	Wio	LinkIt ONE
				

Getting Started

Play With Arduino

Hardware

Materials required

Seeeduino V4.2	Base Shield	Grove - Optocoupler Relay (M281)	Red LED
			

In addition, you can consider our new Seeeduino Lotus M0+, which is equivalent to the combination of Seeeduino V4.2 and Baseshield.

Note

1 Please plug the USB cable gently, otherwise you may damage the port. Please use the USB cable with 4 wires inside, the 2 wires cable can't transfer data. If you are not sure about the wire you have, you can click here to buy

2 Each Grove module comes with a Grove cable when you buy. In case you lose the Grove cable, you can click here to buy.

Hardware Connection

- **Step 1.** Plug Grove - Base Shield into Seeeduino.
- **Step 2.** Connect the Grove - Optocoupler Relay (M281) to the **D5** port of the Base Shield.
- **Step 3.** Connect the LED and the Grove - Optocoupler Relay (M281) to the **3.3V** and **GND** pin of the Grove - Base Shield.(Please refer to the figure below)
- **Step 4.** Connect Seeeduino to PC via a USB cable.

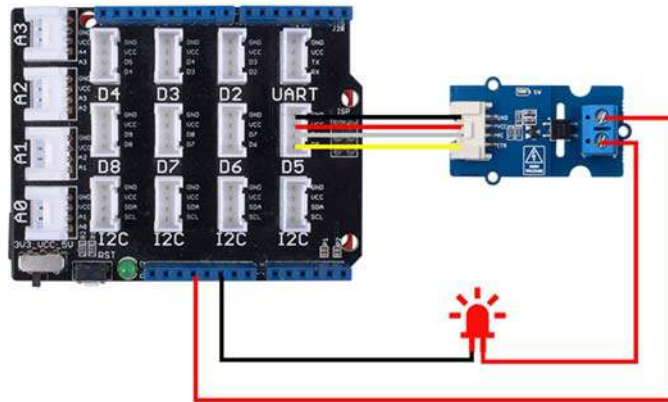

Figure 2. Pinout, please make sure connect to the 3.3v pin, 5v will damage this LED.

Software

Attention

If this is the first time you work with Arduino, we strongly recommend you to see Getting Started with Arduino before the start.

- **Step 1.** Copy the following code into a new sketch in the Arduino IDE

```
1const int Pinout = 5;
2
3void setup() {
4  pinMode(Pinout, OUTPUT);
5  Serial.begin(9600);
6}
7
8void loop() {
9
10  digitalWrite(Pinout, HIGH);
11  delay(500);
12  digitalWrite(Pinout, LOW);
13  delay(500);
14}
```

- **Step 2.** Upload the demo. If you do not know how to upload the code, please check How to upload code.

Success

If everything goes well, we will see the LED flashing.

Tech Support

Please submit any technical issue into our forum or drop mail to techsupport@seeed.cc
http://wiki.seeedstudio.com/Grove-Optocoupler_Relay-M281/4-15-19