

8-Bit Parallel-Input Protected Latched Driver

Features

- 4.4 MHz Minimum Data Input Rate
- High-Voltage, High-Current Outputs
- Per-Output Overcurrent Shutdown (500 mA Typical)
- Undervoltage Lockout
- Thermal Shutdown
- Output Transient Protection Diodes
- CMOS, PMOS, NMOS, and TTL Compatible Inputs
- Internal Pull-Down Resistors
- Low-Power CMOS Latches

Package Types

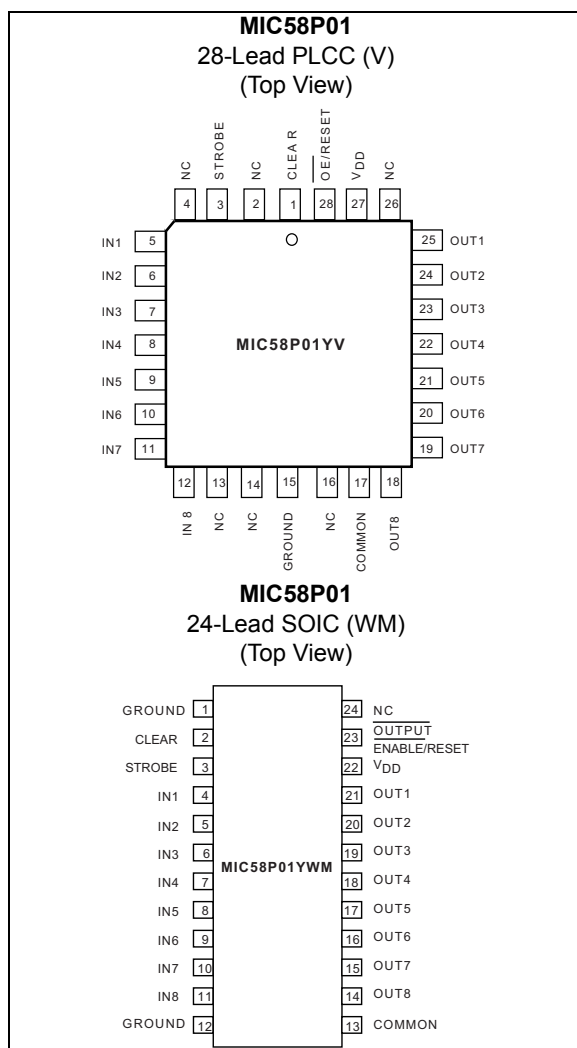

General Description

The MIC58P01 parallel-input latched driver is a high-voltage (80V), high-current (500 mA) integrated circuit comprised of eight CMOS data latches, a bipolar Darlington transistor driver for each latch, and CMOS control circuitry for the common CLEAR, STROBE, and OUTPUT ENABLE functions. Similar to the MIC5801, additional protection circuitry supplied on this device includes thermal shutdown, undervoltage lockout (UVLO), and overcurrent shutdown.

The bipolar/CMOS combination provides an extremely low-power latch with maximum interface flexibility. The MIC58P01 has open-collector outputs capable of sinking 500 mA and integral diodes for inductive load transient suppression with a minimum output breakdown voltage rating of 80V (50V sustaining). The drivers may be connected in parallel for higher load current capability.

With a 5V logic supply, the MIC58P01 will typically operate at better than 5 MHz. With a 12V logic supply, significantly higher speeds are obtained. The CMOS inputs are compatible with standard CMOS, PMOS, and NMOS circuits. TTL circuits may require pull-up resistors.

Each of these eight outputs has an independent overcurrent shutdown of 500 mA. Upon current shutdown, the affected channel will turn off until V_{DD} is cycled or the ENABLE/RESET pin is pulsed high. Current pulses less than 2 μs will not activate current shutdown. Temperatures above 165°C will shut down all outputs. The UVLO circuit disables the outputs at low V_{DD}; hysteresis of 0.5V is provided.

MIC58P01

Typical Application Circuit

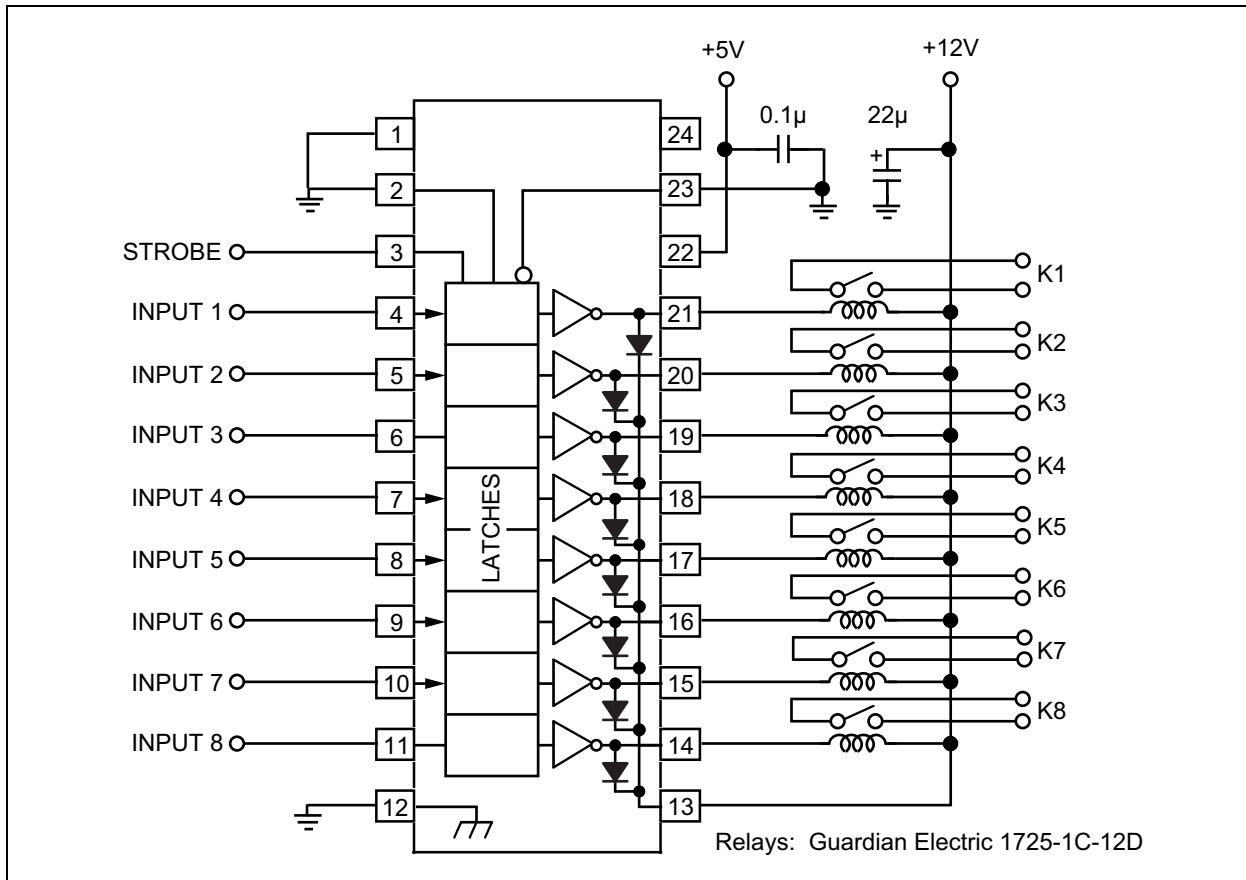

Functional Block Diagram

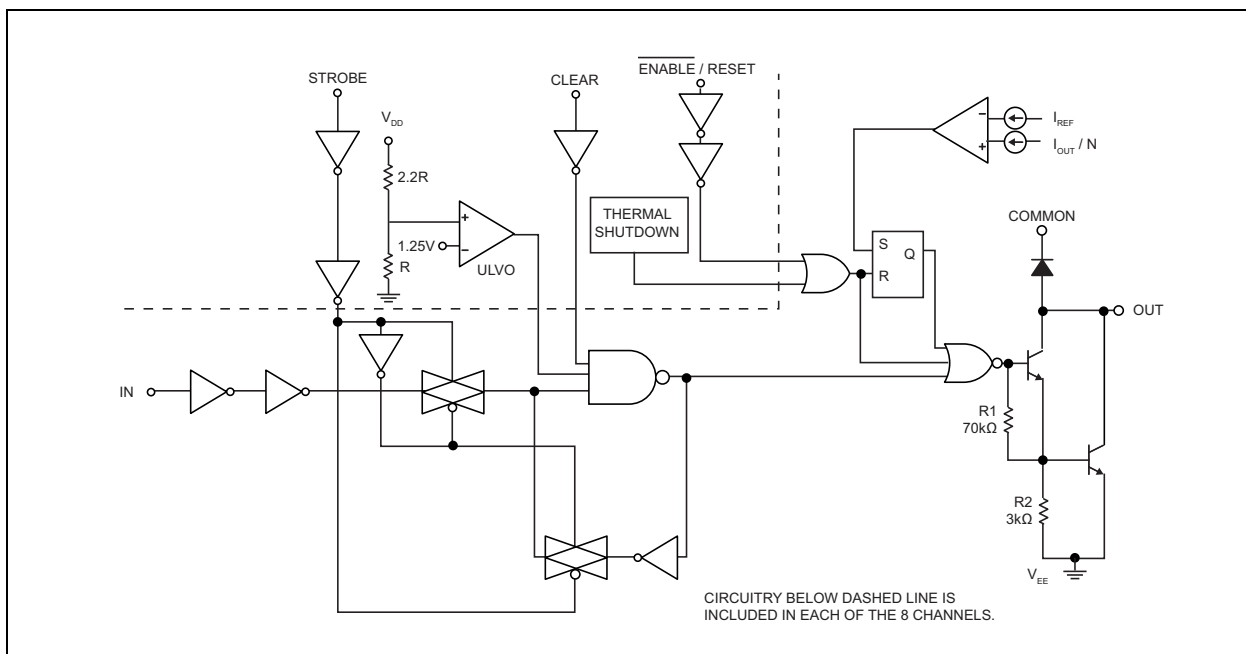

1.0 ELECTRICAL CHARACTERISTICS

Absolute Maximum Ratings †

Output Voltage (V_{CE})	+80V
Logic Supply Voltage (V_{DD})	+15V
Input Voltage Range (V_{IN})	-0.3V to $V_{DD} + 0.3V$
Maximum Operating Ambient Temperature ($T_{A(MAX)}$)	+85°C
Minimum Operating Ambient Temperature ($T_{A(MIN)}$)	-55°C
ESD Rating (Note 1)	ESD Sensitive

Operating Ratings ††

Package Power Dissipation (P_D)	
MIC58P01YV	1.6W
Derate above $T_A = +25^\circ C$	16 mW/°C
MIC58P01YWM	1.4W
Derate above $T_A = +25^\circ C$	14 mW/°C

† Notice: Exceeding the absolute maximum ratings may damage the device.

†† Notice: The device is not guaranteed to function outside its operating ratings.

Note 1: Microchip CMOS devices have input-static protection, but are susceptible to damage when exposed to extremely high static electrical charges.

ELECTRICAL CHARACTERISTICS

Electrical Characteristics: $V_{DD} = 5V$, $T_A = +25^\circ C$, unless otherwise noted. Note 1						
Parameter	Sym.	Min.	Typ.	Max.	Units	Conditions
Output Leakage Current	I_{CEX}	—	—	50	μA	$V_{CE} = 80V$, $T_A = +25^\circ C$
		—	—	100		$V_{CE} = 80V$, $T_A = +70^\circ C$
Collector-Emitter Saturation Voltage	$V_{CE(SAT)}$	—	0.9	1.1	V	$I_C = 100\text{ mA}$
		—	1.1	1.3		$I_C = 200\text{ mA}$
		—	1.3	1.6		$I_C = 350\text{ mA}$
Input Voltage (Low)	$V_{IN(0)}$	—	—	1.0	V	—
Input Voltage (High)	$V_{IN(1)}$	10.5	—	—	V	$V_{DD} = 12V$
		8.5	—	—		$V_{DD} = 10V$
		3.5	—	—		$V_{DD} = 5V$, Note 2
Input Resistance	R_{IN}	50	200	—	k Ω	$V_{DD} = 12V$
		50	300	—		$V_{DD} = 10V$
		50	600	—		$V_{DD} = 5V$

Note 1: Specification for packaged product only.

2: Operation of these devices with standard TTL or DTL may require the use of appropriate pull-up resistors to ensure a minimum logic "1".

3: Undervoltage Lockout is guaranteed to release device at no more than 4.5V, and disable the device at no less than 3.0V.

MIC58P01

ELECTRICAL CHARACTERISTICS (CONTINUED)

Electrical Characteristics: $V_{DD} = 5V$, $T_A = +25^\circ C$, unless otherwise noted. Note 1						
Parameter	Sym.	Min.	Typ.	Max.	Units	Conditions
Supply Current	$I_{DD(1ON)}$	—	3.3	4.5	mA	One Driver ON, $V_{DD} = 12V$, Outputs Open
		—	3.1	4.5		One Driver ON, $V_{DD} = 10V$, Outputs Open
		—	2.4	3.6		One Driver ON, $V_{DD} = 5V$, Outputs Open
	$I_{DD(ON)}$	—	6.4	10.0	mA	All Drivers ON, $V_{DD} = 12V$, Outputs Open
		—	6.0	9.0		All Drivers ON, $V_{DD} = 10V$, Outputs Open
		—	4.7	7.5		All Drivers ON, $V_{DD} = 5V$, Outputs Open
	$I_{DD(OFF)}$	—	3.0	4.5	mA	All Drivers OFF, $V_{DD} = 12V$, Outputs Open, Inputs = 0V
		—	2.2	3.6		All Drivers OFF, $V_{DD} = 5V$, Outputs Open, Inputs = 0V
	Clamp Diode Leakage Current	I_R	—	—	50	μA
—			—	100	$V_R = 80V$, $T_A = +70^\circ C$	
Overcurrent Threshold	I_{LIM}	—	500	—	mA	Per Output
Start-Up Voltage	V_{SU}	3.5	4.0	4.5	V	Note 3
Minimum Operating V_{DD}	$V_{DD(MIN)}$	3.0	3.5	4.0	V	—
Clamp Diode Forward Voltage	V_F	—	1.7	2.0	V	$I_F = 350\text{ mA}$
Thermal Shutdown	—	—	165	—	$^\circ C$	—
Thermal Shutdown Hysteresis	—	—	10	—	$^\circ C$	—

Note 1: Specification for packaged product only.

2: Operation of these devices with standard TTL or DTL may require the use of appropriate pull-up resistors to ensure a minimum logic “1”.

3: Undervoltage Lockout is guaranteed to release device at no more than 4.5V, and disable the device at no less than 3.0V.

TRUTH TABLE

IN_N	Strobe	Clear	Output Enable	OUT_N	
				t – 1	t
0	1	0	0	X	OFF
1	1	0	0	X	ON
X	X	1	X	X	OFF
X	X	X	1	X	OFF
X	0	0	0	ON	ON
X	0	0	0	OFF	OFF

Legend: X = Irrelevant; t – 1 = Previous output state; t = Present output state.

Information present at an input is transferred to its latch when the STROBE is high. A high CLEAR input will set all latches to the output OFF condition regardless of the Data or STROBE input levels. A high OUTPUT ENABLE will set all outputs to the OFF condition, regardless of any other input conditions. When the OUTPUT ENABLE is low, the outputs depend on the state of their respective latches. If current shutdown is activated, the OUTPUT ENABLE must be pulsed high to restore operation. Overtemperature faults are not latched and require no reset pulse.

TEMPERATURE SPECIFICATIONS

Parameters	Sym.	Min.	Typ.	Max.	Units	Conditions
Temperature Ranges						
Maximum Operating Temperature Range	T_A	-55	—	+85	°C	—
Storage Temperature Range	T_S	-65	—	+125	°C	—
Operating Temperature Range	T_A	-40	—	+85	°C	—

Note 1: The maximum allowable power dissipation is a function of ambient temperature, the maximum allowable junction temperature and the thermal resistance from junction to air (i.e., T_A , T_J , θ_{JA}). Exceeding the maximum allowable power dissipation will cause the device operating junction temperature to exceed the maximum +125°C rating. Sustained junction temperatures above +125°C can impact the device reliability.

MIC58P01

2.0 TYPICAL PERFORMANCE CURVES

Note: The graphs and tables provided following this note are a statistical summary based on a limited number of samples and are provided for informational purposes only. The performance characteristics listed herein are not tested or guaranteed. In some graphs or tables, the data presented may be outside the specified operating range (e.g., outside specified power supply range) and therefore outside the warranted range.

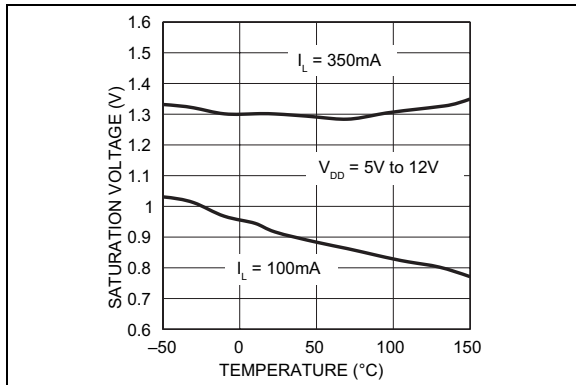

FIGURE 2-1: Output Saturation Voltage vs. Temperature.

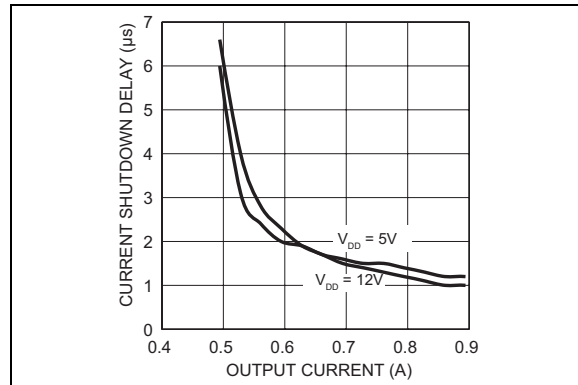

FIGURE 2-4: Current Shutdown Delay vs. Output Current.

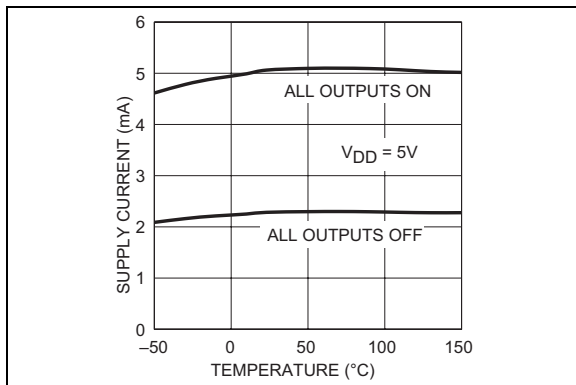

FIGURE 2-2: Supply Current vs. Temperature.

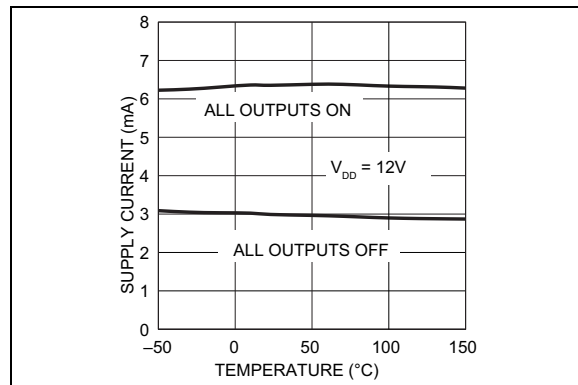

FIGURE 2-5: Supply Current vs. Temperature.

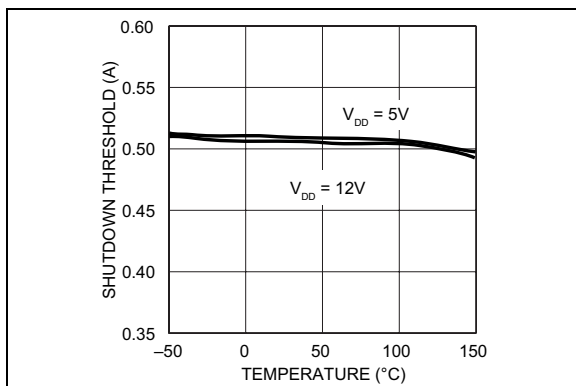

FIGURE 2-3: Current Shutdown Threshold vs. Temperature.

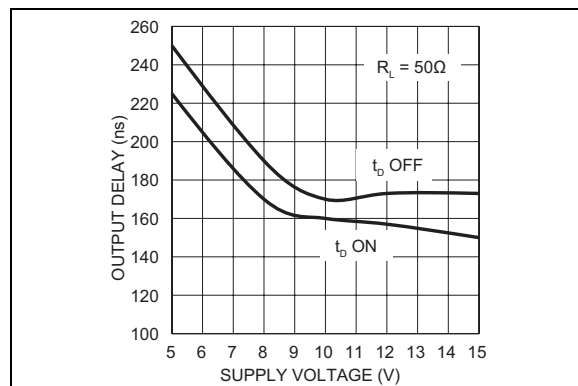

FIGURE 2-6: Output Delay vs. Supply Voltage.

3.0 PIN DESCRIPTIONS

The descriptions of the pins are listed in [Table 3-1](#).

TABLE 3-1: PIN FUNCTION TABLE

Pin Number PLCC	Pin Number SOIC	Pin Name	Description
1	2	CLEAR	Resets all Latches and turns all outputs OFF (open).
3	3	STROBE	Input Strobe Pin. Loads output latches when High.
5, 6, 7, 8, 9, 10, 11, 12	4, 5, 6, 7, 8, 9, 10, 11	IN _N	Parallel Inputs, 1 through 8.
15	1, 12	GROUND	Logic and Output Ground pin.
17	13	COMMON	Transient suppression diode common cathode pin.
18, 19, 20, 21, 22, 23, 24, 25	14, 15, 16, 17, 18, 19, 20, 21	OUT _N	Parallel Outputs, 8 through 1.
27	22	V _{DD}	Logic Supply voltage.
28	23	$\overline{\text{OUTPUT}}\overline{\text{ENABLE}}/\overline{\text{RESET}}$	When Low, Outputs are active. When High, outputs are inactive and device is reset from a fault condition. An undervoltage condition emulates a high $\overline{\text{OE}}$ output.
2, 4, 13, 14, 16, 26	24	NC	No connect.

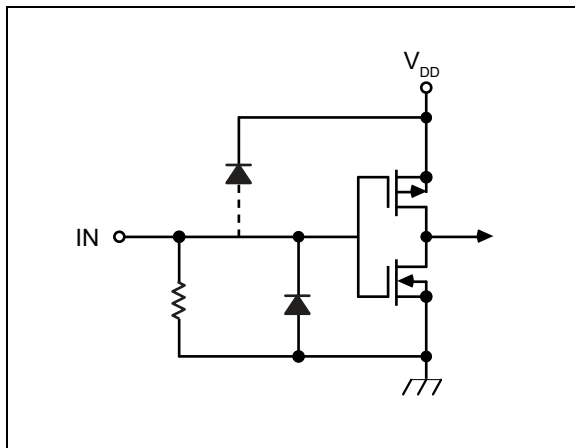

FIGURE 3-1: Typical Input.

MIC58P01

4.0 TIMING

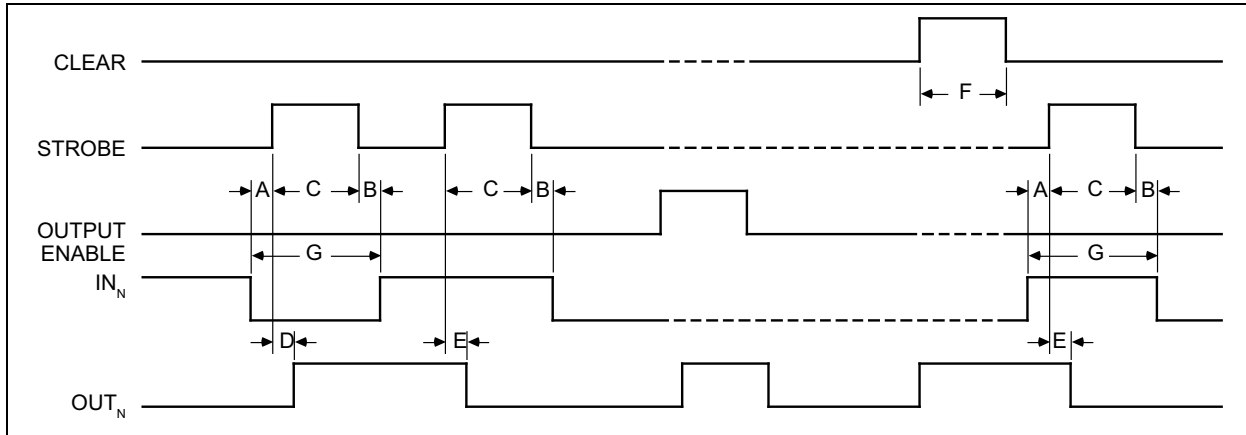

FIGURE 4-1: Timing Diagram.

TABLE 4-1: TIMING CONDITIONS

Characteristics: $T_A = +25^\circ\text{C}$; Logic levels are V_{DD} and Ground; $V_{DD} = 5\text{V}$.

Condition	Min.	Typ.	Max.
Minimum data active time before strobe enabled (data set-up time)	50 ns	—	—
Minimum data active time after strobe disabled (data hold time)	50 ns	—	—
Minimum strobe pulse width	125 ns	—	—
Typical time between strobe activation and output on to off transition	—	500 ns	—
Typical time between strobe activation and output off to on transition	—	500 ns	—
Minimum clear pulse width	300 ns	—	—
Minimum data pulse width	225 ns	—	—

5.0 PACKAGING INFORMATION

5.1 Package Marking Information

28-Lead PLCC*

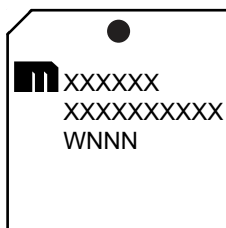

Example

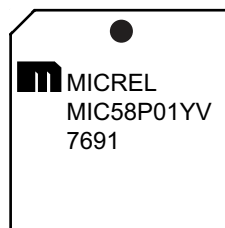

24-Lead SOICW*

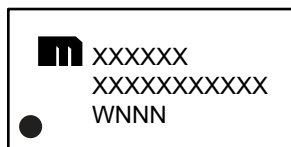

Example



Legend:	XX...X	Product code or customer-specific information
	Y	Year code (last digit of calendar year)
	YY	Year code (last 2 digits of calendar year)
	WW	Week code (week of January 1 is week '01')
	NNN	Alphanumeric traceability code
	(e3)	Pb-free JEDEC® designator for Matte Tin (Sn)
	*	This package is Pb-free. The Pb-free JEDEC designator ((e3)) can be found on the outer packaging for this package.
	•, ▲, ▼	Pin one index is identified by a dot, delta up, or delta down (triangle mark).
Note:	In the event the full Microchip part number cannot be marked on one line, it will be carried over to the next line, thus limiting the number of available characters for customer-specific information. Package may or may not include the corporate logo.	
	Underbar (_) and/or Overbar (¯) symbol may not be to scale.	

MIC58P01

TITLE

28 LEAD PLCC PACKAGE OUTLINE & RECOMMENDED LAND PATTERN

DRAWING #	PLCC-28LD-PL-1	UNIT	INCH [MM]
-----------	----------------	------	-----------

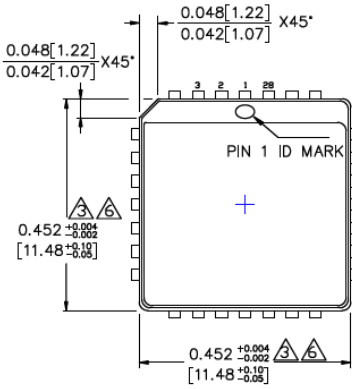

TOP VIEW

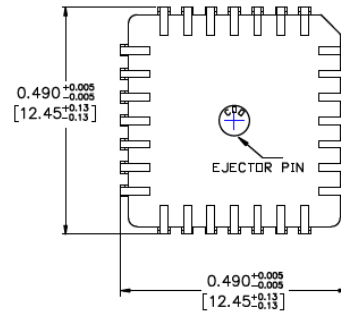

BOTTOM VIEW

DETAIL "A"

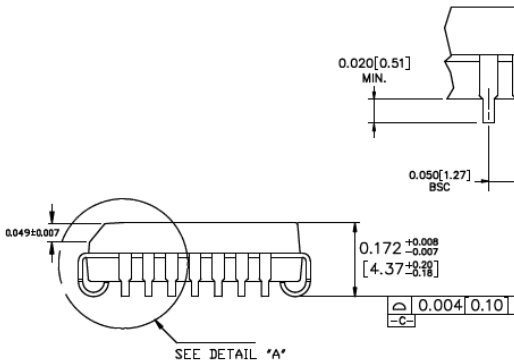

SIDE VIEW

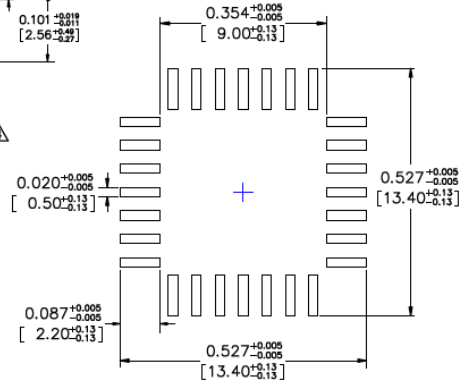

RECOMMENDED LAND PATTERN

NOTES:

1. DIMENSIONS ARE IN INCHES [MM].
2. CONTROLLING DIMENSION: INCHES.
3. DIMENSION DOES NOT INCLUDE MOLD FLASH OR PROTRUSIONS, EITHER OF WHICH SHALL NOT EXCEED 0.008 [0.203].
4. LEAD DIMENSION DOES NOT INCLUDE DAMBAR PROTRUSION.
5. MAXIMUM AND MINIMUM SPECIFICATIONS ARE INDICATED AS FOLLOWS : MAX/MIN
6. PACKAGE TOP DIMENSION MAY BE SLIGHTLY SMALLER THAN BOTTOM DIMENSION.

Note: For the most current package drawings, please see the Microchip Packaging Specification located at <http://www.microchip.com/packaging>.

MIC58P01

TITLE

24 LEAD SOICW PACKAGE OUTLINE & RECOMMENDED LAND PATTERN

DRAWING #	SOICW-24LD-PL-1	UNIT	INCH [MM]
------------------	-----------------	-------------	-----------

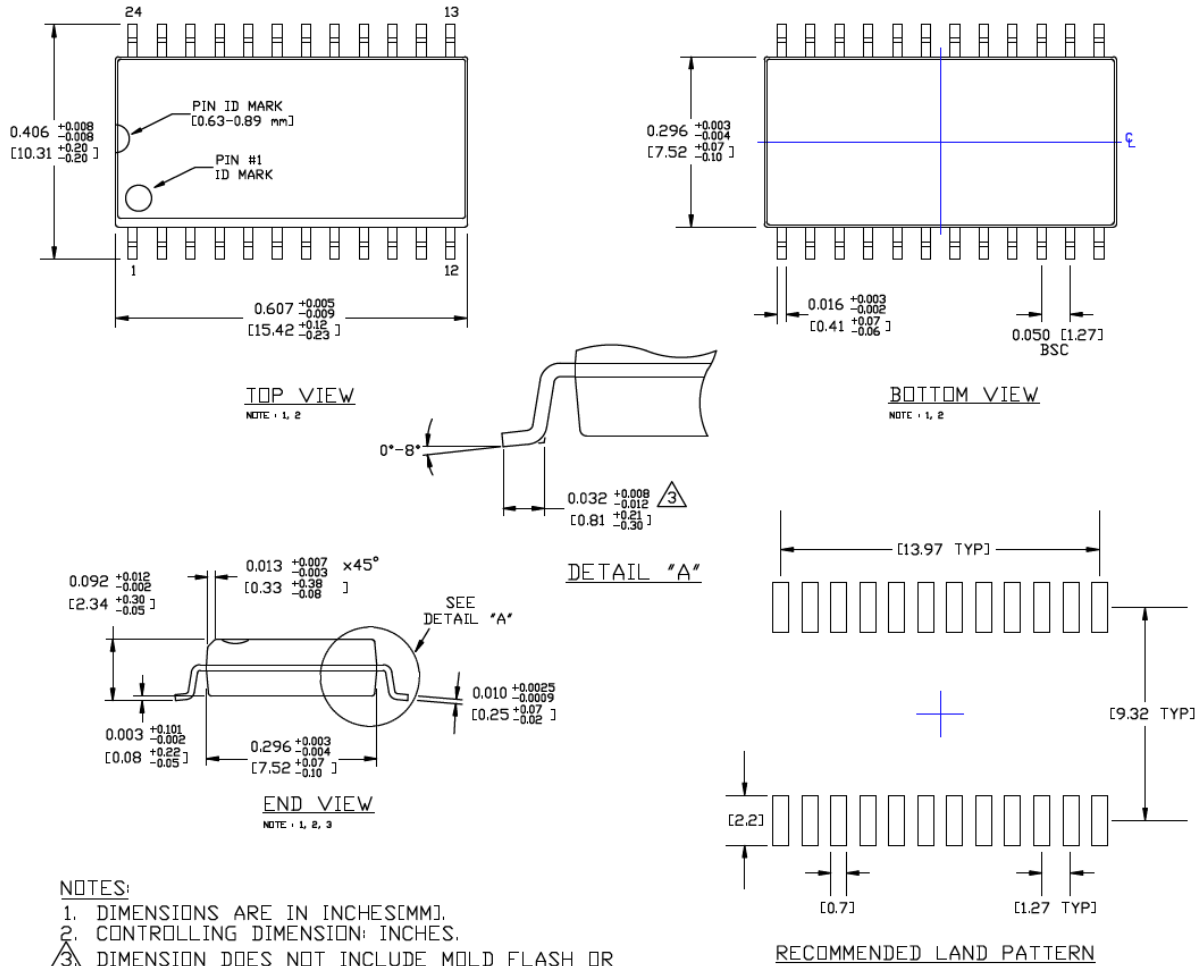

NOTES:

1. DIMENSIONS ARE IN INCHES[MM].
2. CONTROLLING DIMENSION: INCHES.
3. DIMENSION DOES NOT INCLUDE MOLD FLASH OR PROTRUSIONS, EITHER OF WHICH SHALL NOT EXCEED 0.006[0.15] PER SIDE.

Note: For the most current package drawings, please see the Microchip Packaging Specification located at <http://www.microchip.com/packaging>.

MIC58P01

NOTES:

APPENDIX A: REVISION HISTORY

Revision A (February 2019)

- Converted Micrel document MIC58P01 to Microchip data sheet template DS20006159A.
- Minor grammatical text changes throughout.

MIC58P01

NOTES:

PRODUCT IDENTIFICATION SYSTEM

To order or obtain information, e.g., on pricing or delivery, contact your local Microchip representative or sales office.

Device	<u>X</u>	<u>XX</u>	<u>-XX</u>	
Part No.	Junction Temp. Range	Package	Media Type	
Device:	MIC58P01:	8-Bit Parallel Input Protected Latched Driver		
Junction Temperature Range:	Y =	-40°C to +85°C, Industrial		
Package:	V =	28-Lead PLCC		
	WM =	24-Lead Wide SOIC		
Media Type:	<blank>=	38/Tube (PLCC Package)		
	<blank>=	31/Tube (SOIC Package)		
	TR =	750/Reel (PLCC Package)		
	TR =	1,000/Reel (SOIC Package)		
				Examples:
				a) MIC58P01YV: MIC58P01, -40°C to +85°C Temperature Range, 28-Lead PLCC, 38/Tube
				b) MIC58P01YV-TR: MIC58P01, -40°C to +85°C Temperature Range, 28-Lead PLCC, 750/Reel
				c) MIC58P01YWM: MIC58P01, -40°C to +85°C Temperature Range, 24-Lead Wide SOIC, 31/Tube
				d) MIC58P01YWM-TR: MIC58P01, -40°C to +85°C Temperature Range, 24-Lead Wide SOIC, 1,000/Reel
				Note 1: Tape and Reel identifier only appears in the catalog part number description. This identifier is used for ordering purposes and is not printed on the device package. Check with your Microchip Sales Office for package availability with the Tape and Reel option.

MIC58P01

NOTES:

Note the following details of the code protection feature on Microchip devices:

- Microchip products meet the specification contained in their particular Microchip Data Sheet.
- Microchip believes that its family of products is one of the most secure families of its kind on the market today, when used in the intended manner and under normal conditions.
- There are dishonest and possibly illegal methods used to breach the code protection feature. All of these methods, to our knowledge, require using the Microchip products in a manner outside the operating specifications contained in Microchip's Data Sheets. Most likely, the person doing so is engaged in theft of intellectual property.
- Microchip is willing to work with the customer who is concerned about the integrity of their code.
- Neither Microchip nor any other semiconductor manufacturer can guarantee the security of their code. Code protection does not mean that we are guaranteeing the product as “unbreakable.”

Code protection is constantly evolving. We at Microchip are committed to continuously improving the code protection features of our products. Attempts to break Microchip's code protection feature may be a violation of the Digital Millennium Copyright Act. If such acts allow unauthorized access to your software or other copyrighted work, you may have a right to sue for relief under that Act.

Information contained in this publication regarding device applications and the like is provided only for your convenience and may be superseded by updates. It is your responsibility to ensure that your application meets with your specifications. MICROCHIP MAKES NO REPRESENTATIONS OR WARRANTIES OF ANY KIND WHETHER EXPRESS OR IMPLIED, WRITTEN OR ORAL, STATUTORY OR OTHERWISE, RELATED TO THE INFORMATION, INCLUDING BUT NOT LIMITED TO ITS CONDITION, QUALITY, PERFORMANCE, MERCHANTABILITY OR FITNESS FOR PURPOSE. Microchip disclaims all liability arising from this information and its use. Use of Microchip devices in life support and/or safety applications is entirely at the buyer's risk, and the buyer agrees to defend, indemnify and hold harmless Microchip from any and all damages, claims, suits, or expenses resulting from such use. No licenses are conveyed, implicitly or otherwise, under any Microchip intellectual property rights unless otherwise stated.

Microchip received ISO/TS-16949:2009 certification for its worldwide headquarters, design and wafer fabrication facilities in Chandler and Tempe, Arizona; Gresham, Oregon and design centers in California and India. The Company's quality system processes and procedures are for its PIC® MCUs and dsPIC® DSCs, KEELOQ® code hopping devices, Serial EEPROMs, microperipherals, nonvolatile memory and analog products. In addition, Microchip's quality system for the design and manufacture of development systems is ISO 9001:2000 certified.

**QUALITY MANAGEMENT SYSTEM
CERTIFIED BY DNV
= ISO/TS 16949 =**

Trademarks

The Microchip name and logo, the Microchip logo, AnyRate, AVR, AVR logo, AVR Freaks, BitCloud, chipKIT, chipKIT logo, CryptoMemory, CryptoRF, dsPIC, FlashFlex, flexPWR, Heldo, JukeBlox, KeeLoq, Kleer, LANCheck, LINK MD, maXStylus, maXTouch, MediaLB, megaAVR, MOST, MOST logo, MPLAB, OptoLyzer, PIC, picoPower, PICSTART, PIC32 logo, Prochip Designer, QTouch, SAM-BA, SpyNIC, SST, SST Logo, SuperFlash, tinyAVR, UNI/O, and XMEGA are registered trademarks of Microchip Technology Incorporated in the U.S.A. and other countries.

ClockWorks, The Embedded Control Solutions Company, EtherSynch, Hyper Speed Control, HyperLight Load, IntellIMOS, mTouch, Precision Edge, and Quiet-Wire are registered trademarks of Microchip Technology Incorporated in the U.S.A.

Adjacent Key Suppression, AKS, Analog-for-the-Digital Age, Any Capacitor, AnyIn, AnyOut, BodyCom, CodeGuard, CryptoAuthentication, CryptoAutomotive, CryptoCompanion, CryptoController, dsPICDEM, dsPICDEM.net, Dynamic Average Matching, DAM, ECAN, EtherGREEN, In-Circuit Serial Programming, ICSP, INICnet, Inter-Chip Connectivity, JitterBlocker, KleerNet, KleerNet logo, memBrain, Mindi, MiWi, motorBench, MPASM, MPF, MPLAB Certified logo, MPLIB, MPLINK, MultiTRAK, NetDetach, Omniscient Code Generation, PICDEM, PICDEM.net, PICKit, PICtail, PowerSmart, PureSilicon, QMatrix, REAL ICE, Ripple Blocker, SAM-ICE, Serial Quad I/O, SMART-I.S., SQI, SuperSwitcher, SuperSwitcher II, Total Endurance, TSHARC, USBCheck, VariSense, ViewSpan, WiperLock, Wireless DNA, and ZENA are trademarks of Microchip Technology Incorporated in the U.S.A. and other countries.

SQTP is a service mark of Microchip Technology Incorporated in the U.S.A.

Silicon Storage Technology is a registered trademark of Microchip Technology Inc. in other countries.

GestIC is a registered trademark of Microchip Technology Germany II GmbH & Co. KG, a subsidiary of Microchip Technology Inc., in other countries.

All other trademarks mentioned herein are property of their respective companies.

© 2019, Microchip Technology Incorporated, All Rights Reserved.
ISBN: 978-1-5224-4211-0



MICROCHIP

Worldwide Sales and Service

AMERICAS

Corporate Office
2355 West Chandler Blvd.
Chandler, AZ 85224-6199
Tel: 480-792-7200
Fax: 480-792-7277
Technical Support:
<http://www.microchip.com/support>
Web Address:
www.microchip.com

Atlanta

Duluth, GA
Tel: 678-957-9614
Fax: 678-957-1455

Austin, TX

Tel: 512-257-3370

Boston

Westborough, MA
Tel: 774-760-0087
Fax: 774-760-0088

Chicago

Itasca, IL
Tel: 630-285-0071
Fax: 630-285-0075

Dallas

Addison, TX
Tel: 972-818-7423
Fax: 972-818-2924

Detroit

Novi, MI
Tel: 248-848-4000

Houston, TX

Tel: 281-894-5983

Indianapolis

Noblesville, IN
Tel: 317-773-8323
Fax: 317-773-5453
Tel: 317-536-2380

Los Angeles

Mission Viejo, CA
Tel: 949-462-9523
Fax: 949-462-9608
Tel: 951-273-7800

Raleigh, NC

Tel: 919-844-7510

New York, NY

Tel: 631-435-6000

San Jose, CA

Tel: 408-735-9110
Tel: 408-436-4270

Canada - Toronto

Tel: 905-695-1980
Fax: 905-695-2078

ASIA/PACIFIC

Australia - Sydney
Tel: 61-2-9868-6733

China - Beijing
Tel: 86-10-8569-7000

China - Chengdu
Tel: 86-28-8665-5511

China - Chongqing
Tel: 86-23-8980-9588

China - Dongguan
Tel: 86-769-8702-9880

China - Guangzhou
Tel: 86-20-8755-8029

China - Hangzhou
Tel: 86-571-8792-8115

China - Hong Kong SAR
Tel: 852-2943-5100

China - Nanjing
Tel: 86-25-8473-2460

China - Qingdao
Tel: 86-532-8502-7355

China - Shanghai
Tel: 86-21-3326-8000

China - Shenyang
Tel: 86-24-2334-2829

China - Shenzhen
Tel: 86-755-8864-2200

China - Suzhou
Tel: 86-186-6233-1526

China - Wuhan
Tel: 86-27-5980-5300

China - Xian
Tel: 86-29-8833-7252

China - Xiamen
Tel: 86-592-2388138

China - Zhuhai
Tel: 86-756-3210040

ASIA/PACIFIC

India - Bangalore
Tel: 91-80-3090-4444

India - New Delhi
Tel: 91-11-4160-8631

India - Pune
Tel: 91-20-4121-0141

Japan - Osaka
Tel: 81-6-6152-7160

Japan - Tokyo
Tel: 81-3-6880-3770

Korea - Daegu
Tel: 82-53-744-4301

Korea - Seoul
Tel: 82-2-554-7200

Malaysia - Kuala Lumpur
Tel: 60-3-7651-7906

Malaysia - Penang
Tel: 60-4-227-8870

Philippines - Manila
Tel: 63-2-634-9065

Singapore
Tel: 65-6334-8870

Taiwan - Hsin Chu
Tel: 886-3-577-8366

Taiwan - Kaohsiung
Tel: 886-7-213-7830

Taiwan - Taipei
Tel: 886-2-2508-8600

Thailand - Bangkok
Tel: 66-2-694-1351

Vietnam - Ho Chi Minh
Tel: 84-28-5448-2100

EUROPE

Austria - Wels
Tel: 43-7242-2244-39
Fax: 43-7242-2244-393

Denmark - Copenhagen
Tel: 45-4450-2828
Fax: 45-4485-2829

Finland - Espoo
Tel: 358-9-4520-820

France - Paris
Tel: 33-1-69-53-63-20
Fax: 33-1-69-30-90-79

Germany - Garching
Tel: 49-8931-9700

Germany - Haan
Tel: 49-2129-3766400

Germany - Heilbronn
Tel: 49-7131-67-3636

Germany - Karlsruhe
Tel: 49-721-625370

Germany - Munich
Tel: 49-89-627-144-0
Fax: 49-89-627-144-44

Germany - Rosenheim
Tel: 49-8031-354-560

Israel - Ra'anana
Tel: 972-9-744-7705

Italy - Milan
Tel: 39-0331-742611
Fax: 39-0331-466781

Italy - Padova
Tel: 39-049-7625286

Netherlands - Drunen
Tel: 31-416-690399
Fax: 31-416-690340

Norway - Trondheim
Tel: 47-7288-4388

Poland - Warsaw
Tel: 48-22-3325737

Romania - Bucharest
Tel: 40-21-407-87-50

Spain - Madrid
Tel: 34-91-708-08-90
Fax: 34-91-708-08-91

Sweden - Gothenberg
Tel: 46-31-704-60-40

Sweden - Stockholm
Tel: 46-8-5090-4654

UK - Wokingham
Tel: 44-118-921-5800
Fax: 44-118-921-5820