

IRAUDAMP7S

**25W-500W Scalable Output Power
Class D Audio Power Amplifier Reference Design
Using the IRS2092S Protected Digital Audio Driver**

By

Jun Honda, Manuel Rodríguez, Liwei Zheng

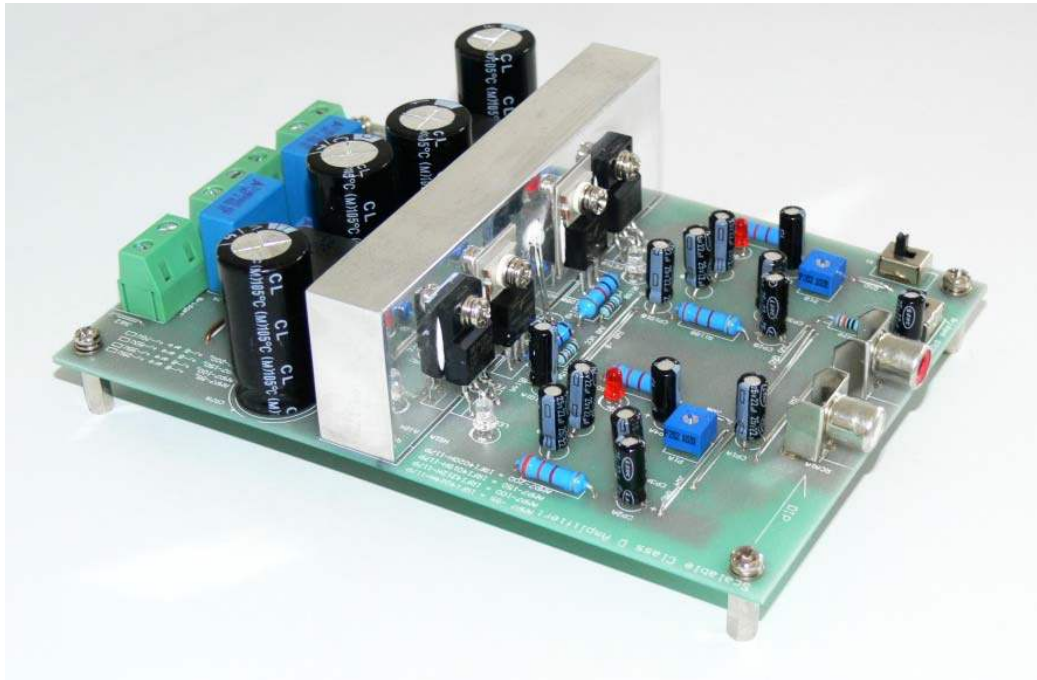

CAUTION:

International Rectifier suggests the following guidelines for safe operation and handling of IRAUDAMP7S Demo Board:

- **Always wear safety glasses whenever operating Demo Board**
- **Avoid personal contact with exposed metal surfaces when operating Demo Board**
- **Turn off Demo Board when placing or removing measurement probes**

Item	Table of Contents	Page
1	Introduction of scalable design	3
2	Power table values for each power model.....	4
3	Specifications.....	4-5
4	Connection setup.....	6
5	Test procedure.....	7
6	Performance and test graphs.....	8-13
7	Clipping characteristics.....	14
8	Efficiency.....	14-16
9	Thermal considerations.....	16
10	PSRR, half bridge, full bridge.....	16-17
11	Short circuit response.....	17-18
12	IRAUDAMP7S Overview.....	18-19
13	Functions Descriptions.....	20-22
14	Selectable dead Time.....	22
15	Protection Features.....	23-25
16	Click and pop noise control.....	25
17	Bus pumping.....	26-27
18	Bridged configuration.....	27
19	Input signal and Gain.....	29
20	Gain settings.....	29
21	Schematics.....	30-32
22	Bill of Materials.....	33-36
23	IRAUDAMP7S models differential table.....	37
24	Hardware.....	38-39
25	PCB specifications.....	40
26	Assembly Drawings.....	41
27	Revision changes descriptions.....	42

Introduction

The IRAUDAMP7S reference design is a two-channel Class D audio power amplifier that features output power scalability. The IRAUDAMP7S offers selectable half-bridge (stereo) and full-bridge (bridged) modes.

This reference design demonstrates how to use the IRS2092 Class D audio driver IC, along with IR's digital audio dual MOSFETs, such as IRFI4024H-117P, IRFI4019H-117P, IRFI4212H-117P and IRFI4020H-117P, on a single layer PCB. The design shows how to implement peripheral circuits on an optimum PCB layout using a single sided board.

The resulting design requires a small heatsink for normal operation (one-eighth of continuous rated power). The reference design provides all the required housekeeping power supplies and protections.

Unless otherwise noted, this user's manual is based on 150V model, IRAUDAMP7S-150.

Other output power versions can be configured by replacing components given in the component selection of Table 5 on page 36

Applications

- AV receivers
- Home theater systems
- Mini component stereos
- Powered speakers
- Sub-woofers
- Musical Instrument amplifiers
- Automotive after market amplifiers

Features

Output Power:	Scalable output power from 25W- 500W (see Table 1)
Residual Noise:	200 μ V, IHF-A weighted, AES-17 filter
Distortion:	0.007 % THD+N @ 60W, 4 Ω
Efficiency:	90 % @ 500W, 8 Ω , Class D stage
Multiple Protection Features:	Over-current protection (OCP), high side and low side MOSFET Over-voltage protection (OVP), Under-voltage protection (UVP), high side and low side MOSFET DC-protection (DCP), Over-temperature protection (OTP)
PWM topology:	Self-oscillating PWM, half-bridge or full-bridge topologies selectable

Table 1 IRAUDAMP7S Specification Table Series

Item		Model Name			
		AMP7S-55	AMP7S-100	AMP7S-150	AMP7S-200
IR Power MOSFET	FET1A, FET1B	IRFI4024H-117P	IRFI4212H-117P	IRFI4019H-117P	IRFI4020H-117P
Half Bridge	8 Ω	25W x 2	60W x 2	125W x 2	250W x 2
	4 Ω	50W x 2	120W x 2	250W x 2	Not Supported
Full Bridge	8 Ω	100W x 1	240W x 1	500W x 1	Not Supported
Nominal Supply Voltage	+B, -B	±25V	±35V	±50V	±70V
Min/Max Supply Voltage	+B, -B	±20V ~ ±28V	±28V ~ ±45V	±45V ~ ±60V	±60V ~ ±80V
Voltage Gain	Gv	20	30	36	40

Notes:

- All the power ratings are at clipping power (THD+N = 1 %). To estimate power ratings at THD+N=10%, multiply them by 1.33
- See Table 5 on page 36 for the complete listing of components table.

Specifications

General Test Conditions for IRAUDAMP7S-150 (unless otherwise noted) Notes / Conditions

Power Supply Voltages	± 50V
Load Impedance	4 Ω
Self-Oscillating Frequency	400kHz
Voltage Gain	36

Electrical Data

Typical

Notes / Conditions

IR Devices Used	IRS2092, Protected digital audio driver IRFI4024H-117P, IRFI4019H-117P, IRFI4212H-117P, IRFI4020H-117P Digital audio MOSFETs	
PWM Modulator	Self-oscillating, second order sigma-delta modulation, analog input	
Power Supply Range	± 45V to ± 60V	Or see table 1 above
Output Power CH1-2: (1 % THD+N)	300W	1kHz
Output Power CH1-2: (10 % THD+N)	400W	1kHz
Rated Load Impedance	8 - 4 Ω	Resistive load
Standby Supply Current	+50 mA/-80 mA	No input signal
Total Idle Power Consumption	7W	No input signal
Channel Efficiency	90 %	Single-channel driven, 250W

Audio Performance

	Before Demodulator	Class D Output	Notes / Conditions
THD+N, 1W THD+N, 10W THD+N, 60W THD+N, 100W	0.01 % 0.005 % 0.005 % 0.007 %	0.02 % 0.007 % 0.007 % 0.008 %	1kHz, Single-channel driven
Dynamic Range	101 dB	101 dB	A-weighted, AES-17 filter, Single-channel operation
Residual Noise	200 μ V	200 μ V	22 Hz – 20kHz, AES17 filter Self-oscillating frequency 400kHz
Damping Factor	2000	120	1kHz, relative to 4 Ω load
Channel Separation	95 dB 85 dB 75 dB	90 dB 80 dB 65 dB	100Hz 1kHz 10kHz
Frequency Response : 20 Hz-20kHz	20 Hz-35kHz	\pm 3 dB	1W, 4 Ω – 8 Ω Load

Thermal Performance (T_A=25 °C)

Condition	Typical	Notes / Conditions
Idling	T _C =30 °C T _{PCB} =37 °C	No signal input
2 ch x 31W (1/8 rated power)	T _C =54 °C T _{PCB} =67 °C	
2 ch x 250W (Rated power)	T _C =80 °C T _{PCB} =106 °C	OTP shutdown after 150 s

Physical Specifications

Dimensions	5.7"(L) x 4"(W) x 1.25"(H) 145 mm (L) x 100 mm (W) x 35 mm(H)
Weight	0.330kgm

Test Setup

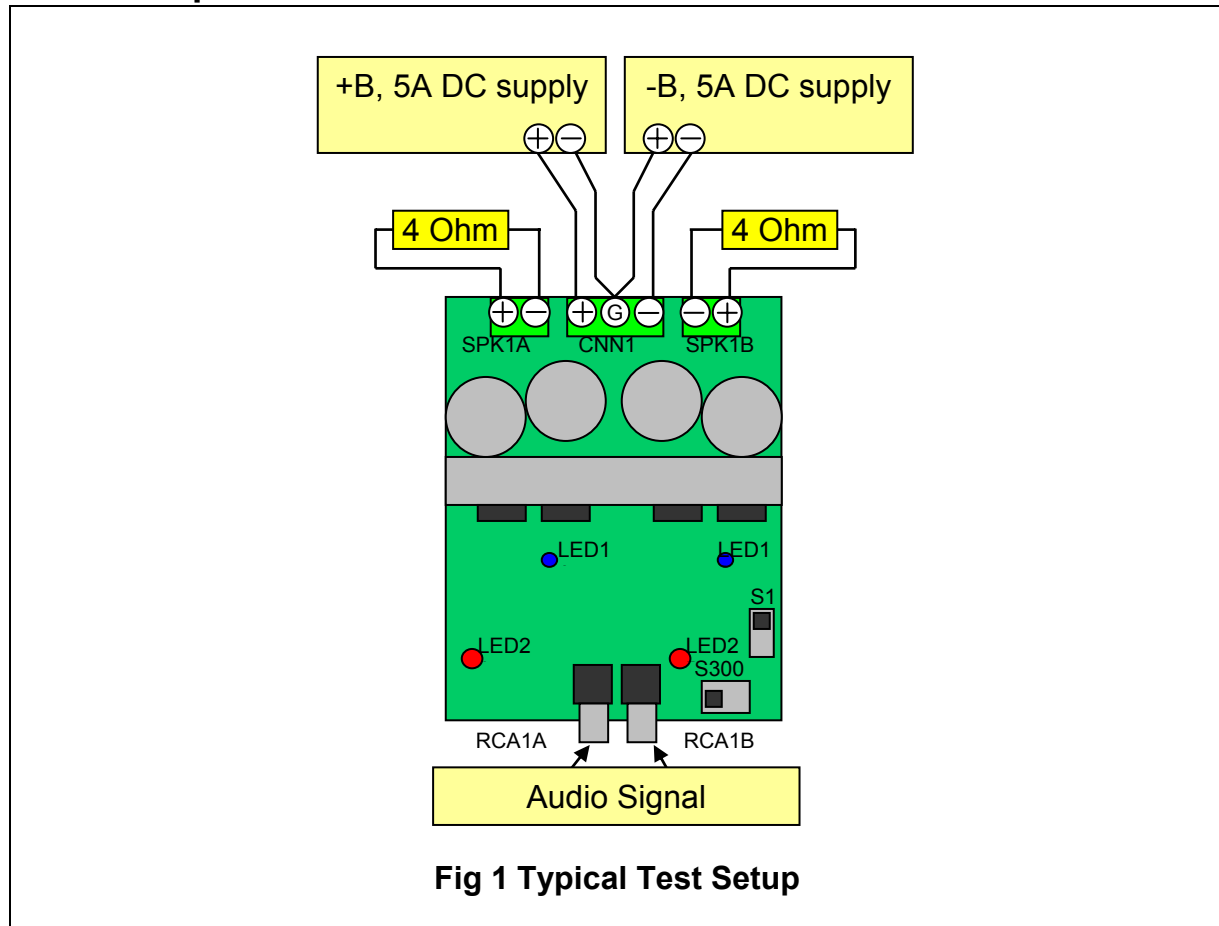

Connector Description

CH1 IN	RCA1A	Analog input for CH1
CH2 IN	RCA1B	Analog input for CH2
SUPPLY	CNN1	Positive and negative supply (+B / -B)
CH1 OUT	SPK1A	Output for CH1
CH2 OUT	SPK1B	Output for CH2

Switches Descriptions

S1	Shutdown PWM
S300	Half bridge / Full bridge select

Indicator Description

LED1A, B	PWM (presence of low side gate signal)
LED2A, B	Protection

Test Procedures

Test Setup:

1. On the unit under test (UUT), set switch S1 to OFF and S300 to Stereo positions.
2. Connect 4 Ω -200 W dummy loads to output connectors, SPKR1A and SPKR1B, as shown on Fig 1.
3. Set up a dual power supply $\pm 50V$ with 5A current limit
4. Turn OFF the dual power supply before connecting to UUT.
5. Connect the dual power supply to CNN1, as shown in Fig 1.

Power up:

6. Turn ON the dual power supply. The $\pm B$ supplies must be applied and removed at the same time.
7. The red LEDs (Protections) turn ON immediately and stay on as long as S1 is in OFF position. Blue LEDs stay OFF.
8. Quiescent current for the positive and negative supplies must be less than 50mA, while S1 is in OFF position. Under this condition, IRS2092 is in shutdown mode.
9. Slide S1 to ON position; after one second delay, the two blue LEDs turn ON and the red LEDs turns off. The two blue LEDs indicate that PWM oscillation is present. This transition delay time is controlled by CSD pin of IRS2092, capacitor CP3
10. Under the normal operating condition with no input signal applied, quiescent current for the positive supply must be less than 50 mA; the negative supply current must be less than 100 mA.

Switching Frequency Test:

11. With an oscilloscope, monitor switching waveform at test points VS1 & VS2 Adjust P1A & P1B to change self oscillating frequency to $400kHz \pm 25kHz$.
Note: To change self-oscillating switching frequency, Adjust the potentiometer resistances of P11A and P11B for CH1 and CH2 respectively.

Audio Functionality Tests:

12. Set the signal generator to 1kHz, 20 mV_{RMS} output.
13. Connect audio signal generators to RCA1A and RCA1B.
14. Sweep the audio signal voltage from 15 mV_{RMS} to 1 V_{RMS}.
15. Monitor the output signals at SPK1A/B with an oscilloscope. Waveform must be a non distorted sinusoidal signal.
16. Observe 1 V_{RMS} input generates output voltage of 36 V_{RMS}. The ratio, $R8/(R7+R2)$, determines the voltage gain of IRAUDAMP7S.
17. Set switch S300 to Bridged position.
18. Observe that voltage gain doubles.

Test Setup using Audio Precision (Ap):

19. Use unbalance-floating signal generator outputs.
20. Use balanced inputs taken across output terminals, SPKR1A and SPKR1B.
21. Connect Ap frame ground to GND in terminal CNN1.
22. Place AES-17 filter for all the testing except frequency response.
23. Use signal voltage sweep range from 15 mV_{RMS} to 1 V_{RMS}.
24. Run Ap test programs for all subsequent tests as shown in Fig 2- Fig 13 below.

Test Results

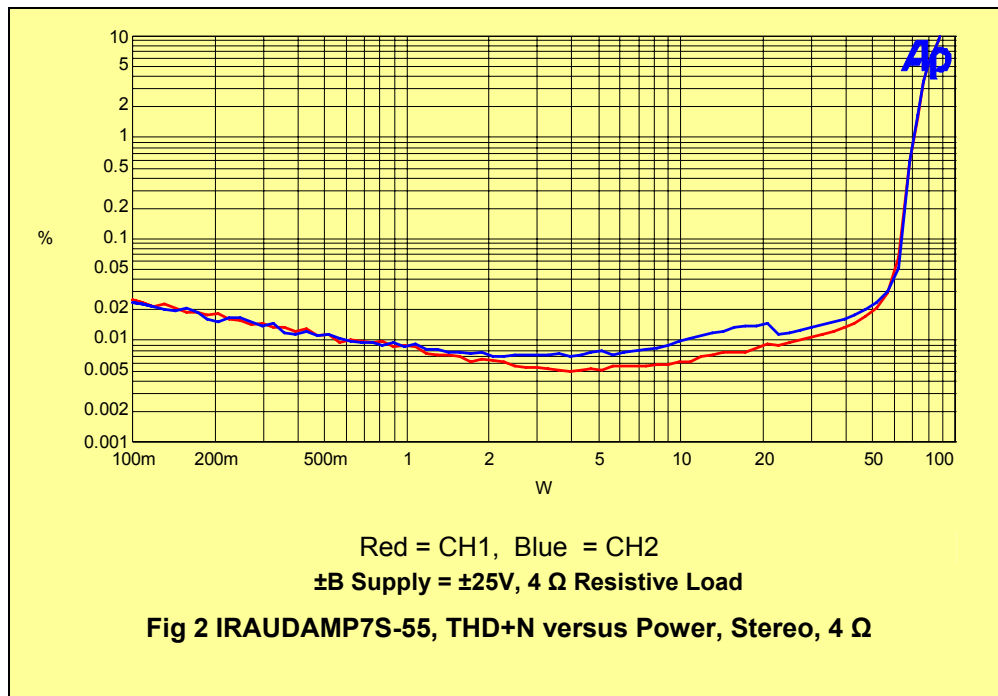

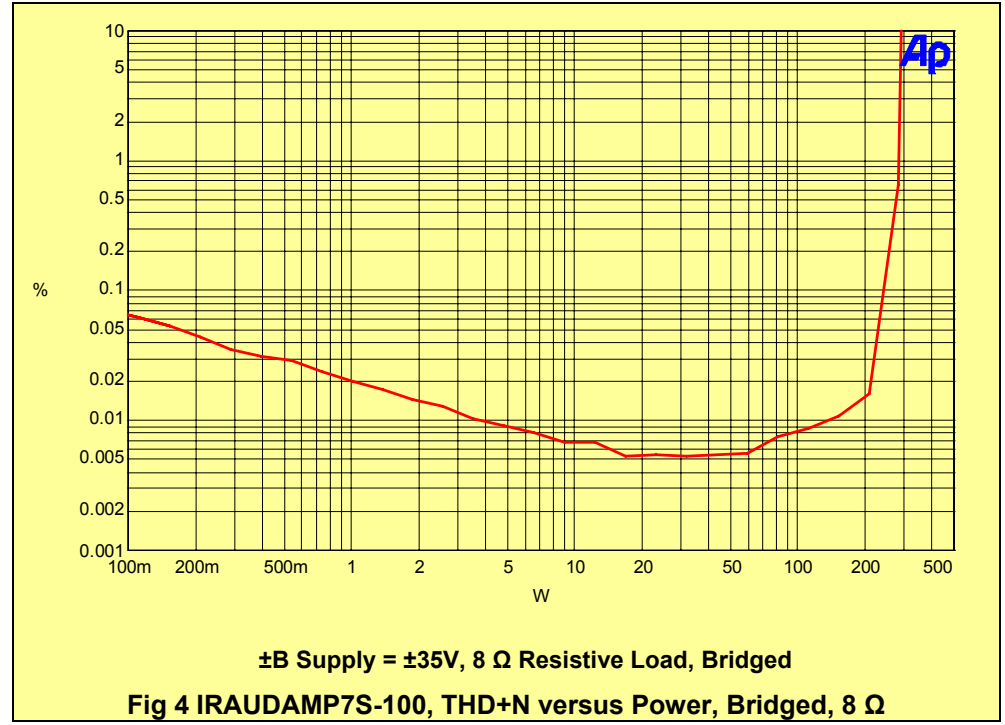
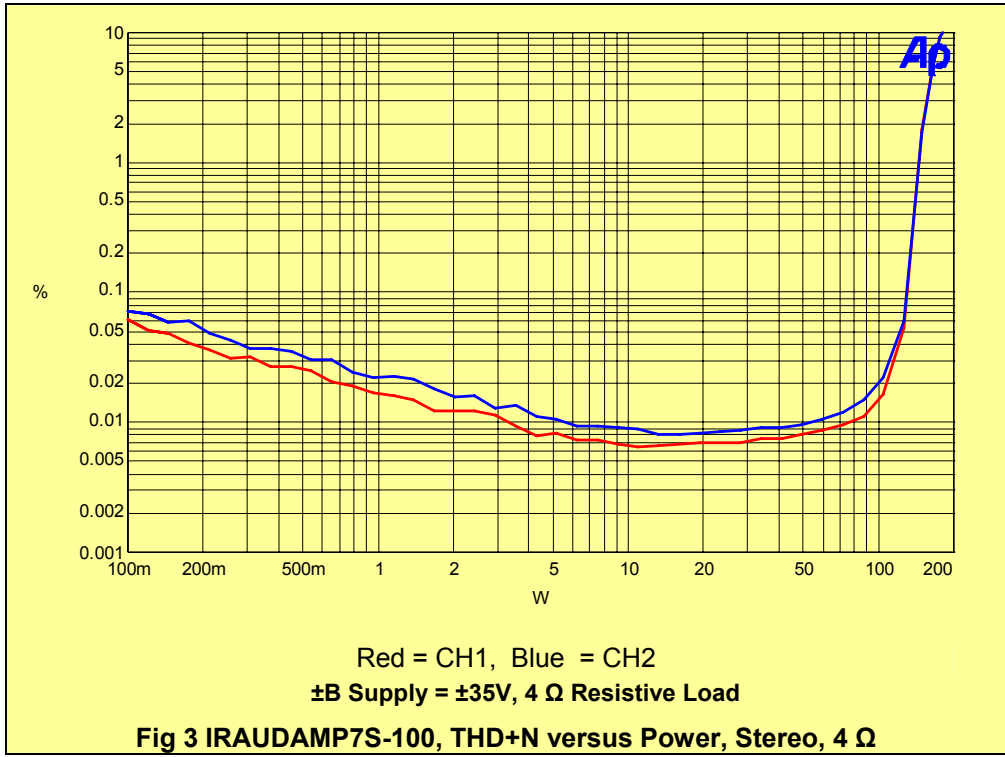

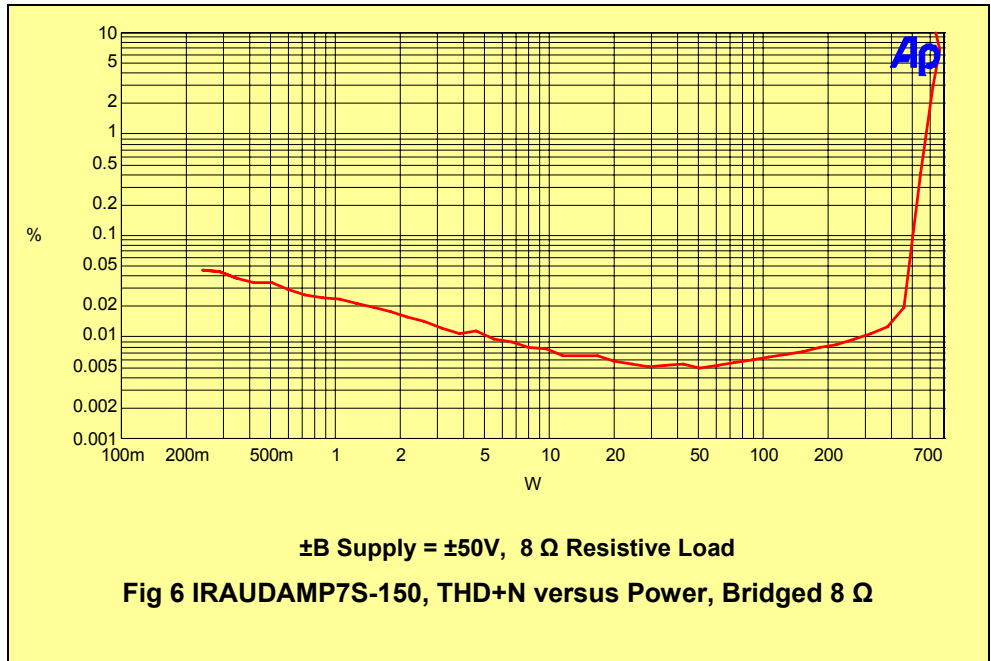
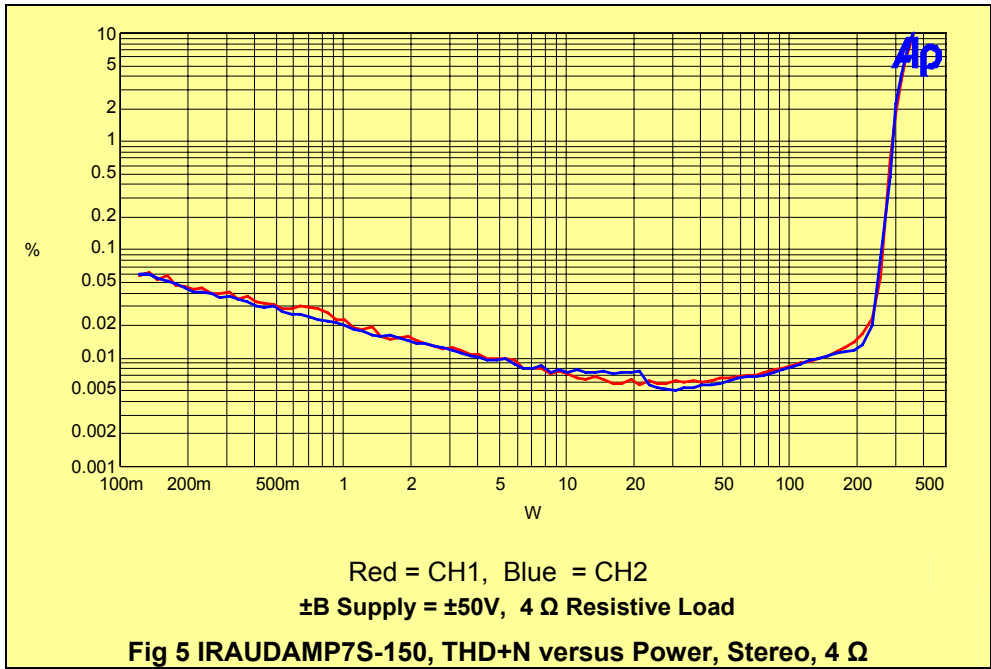

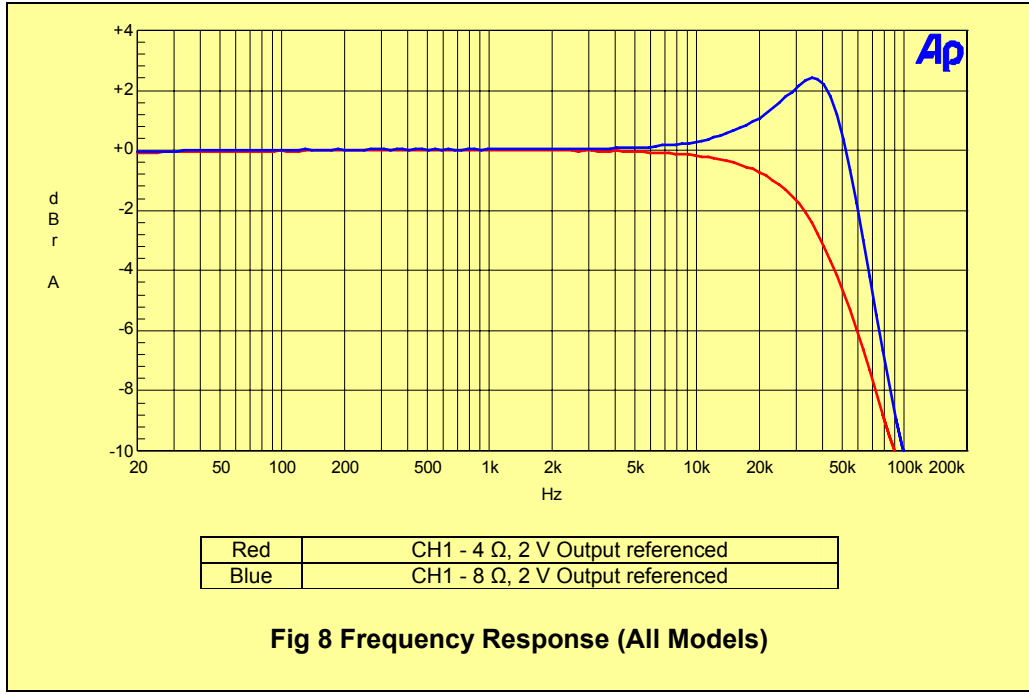
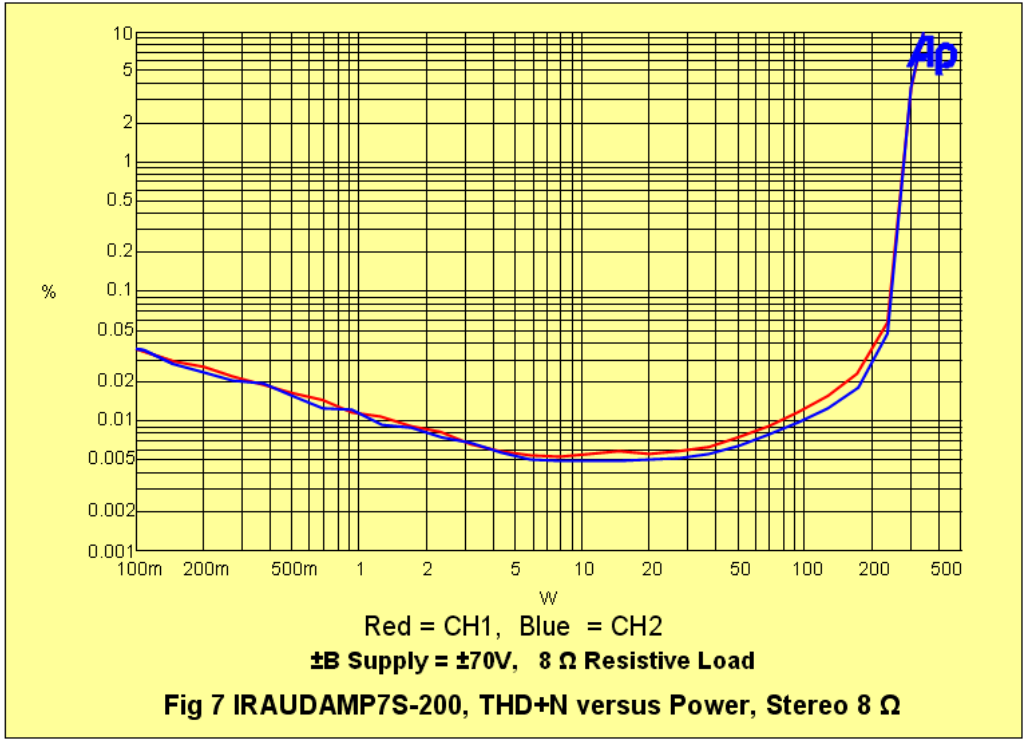

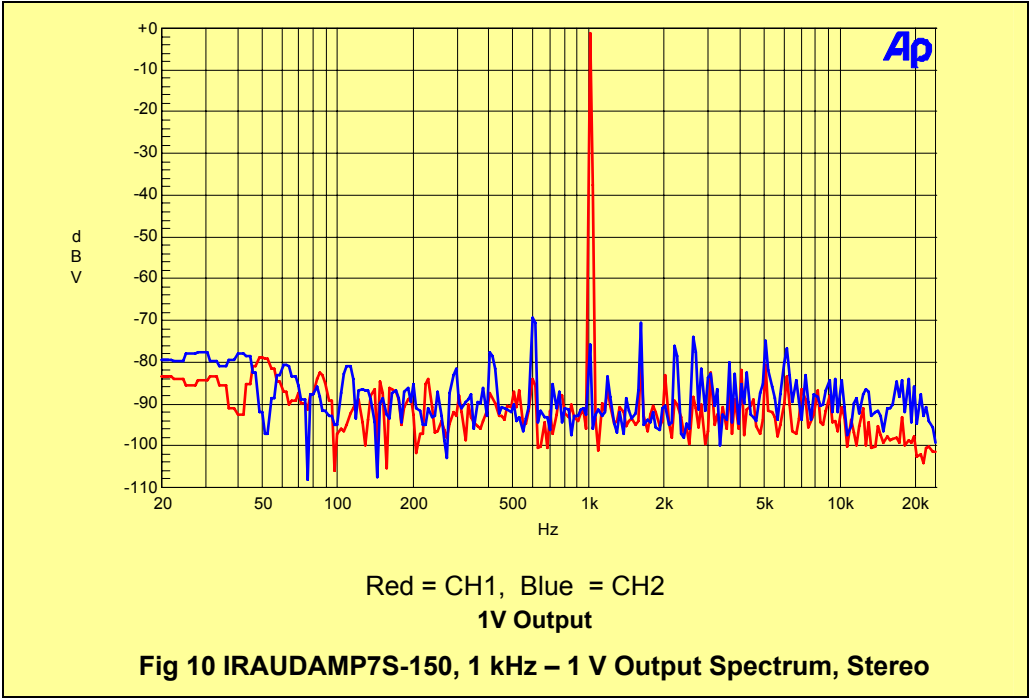
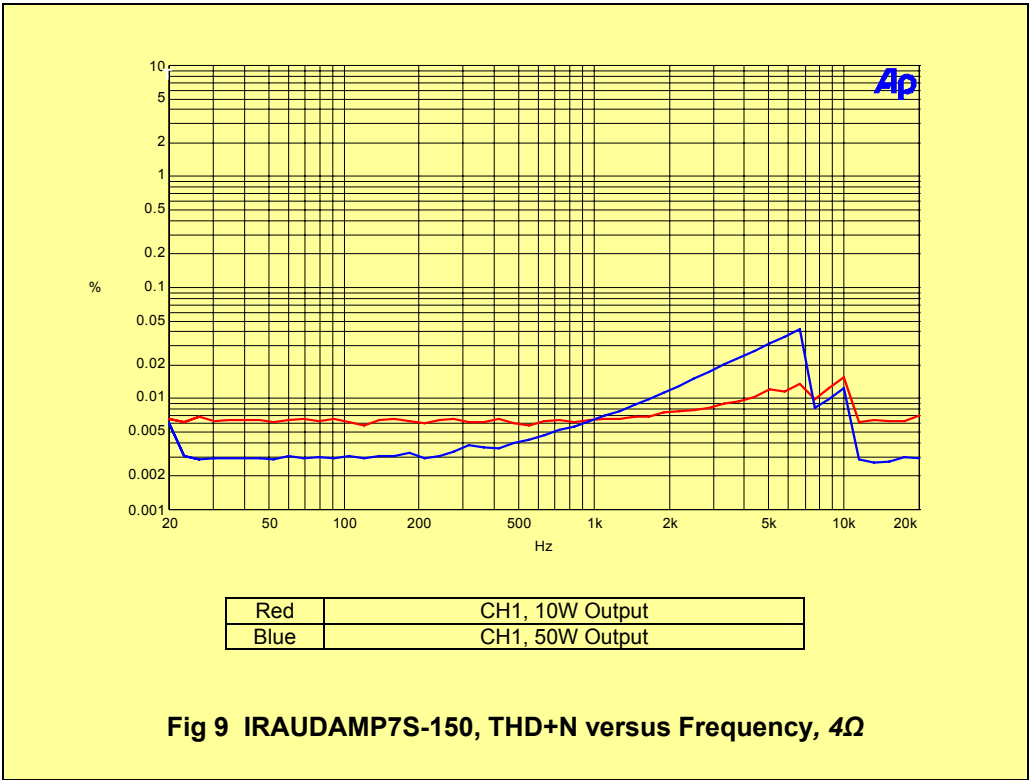

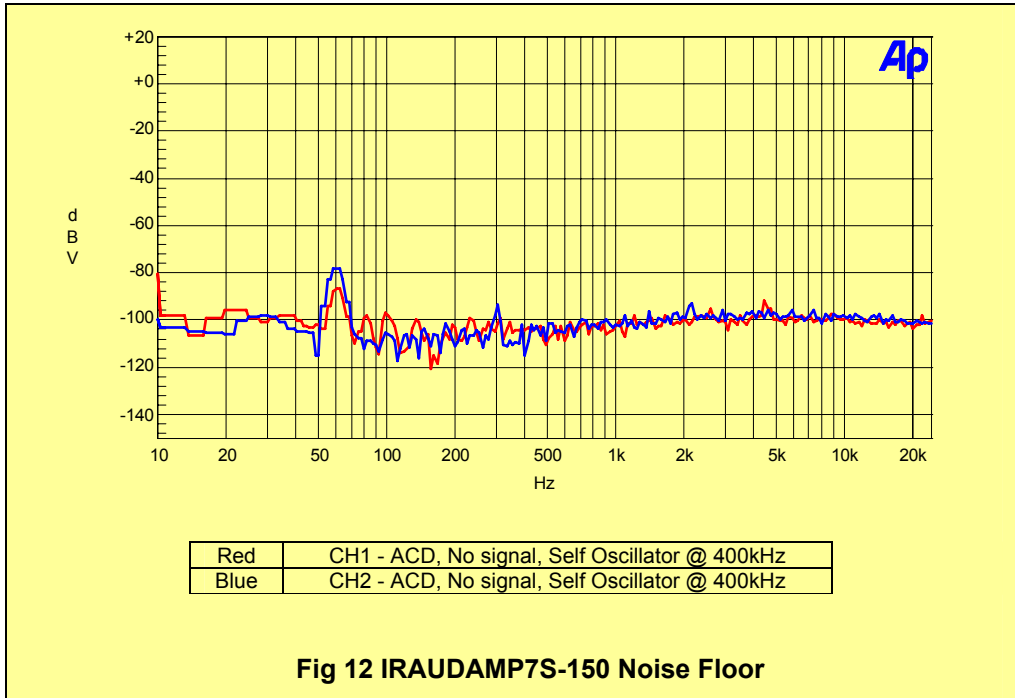
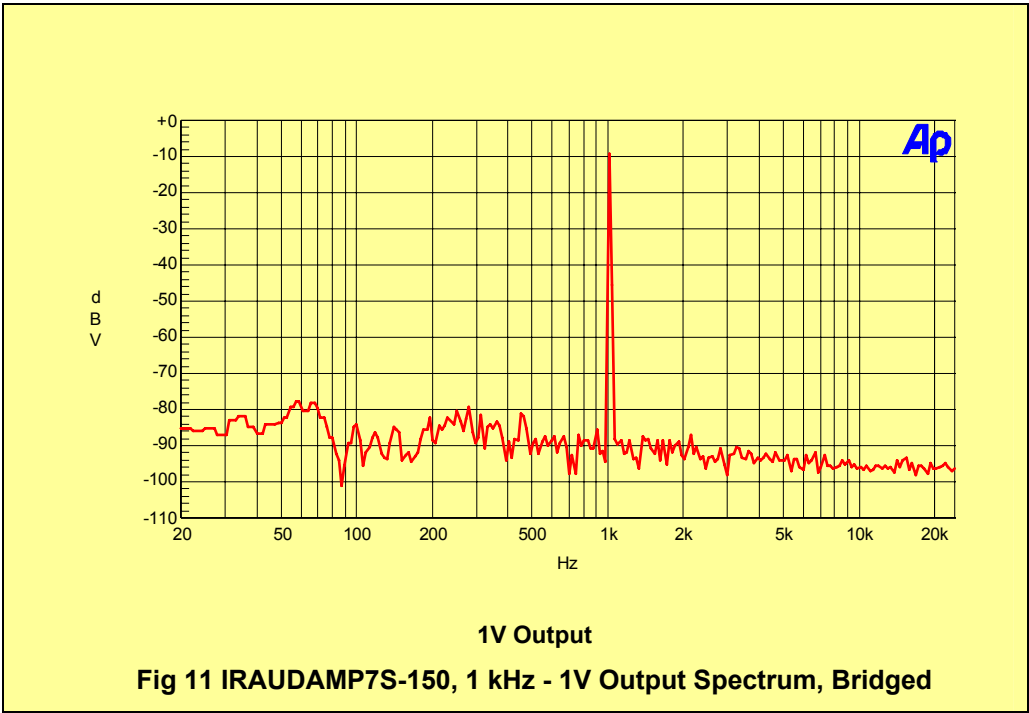

Clipping characteristics

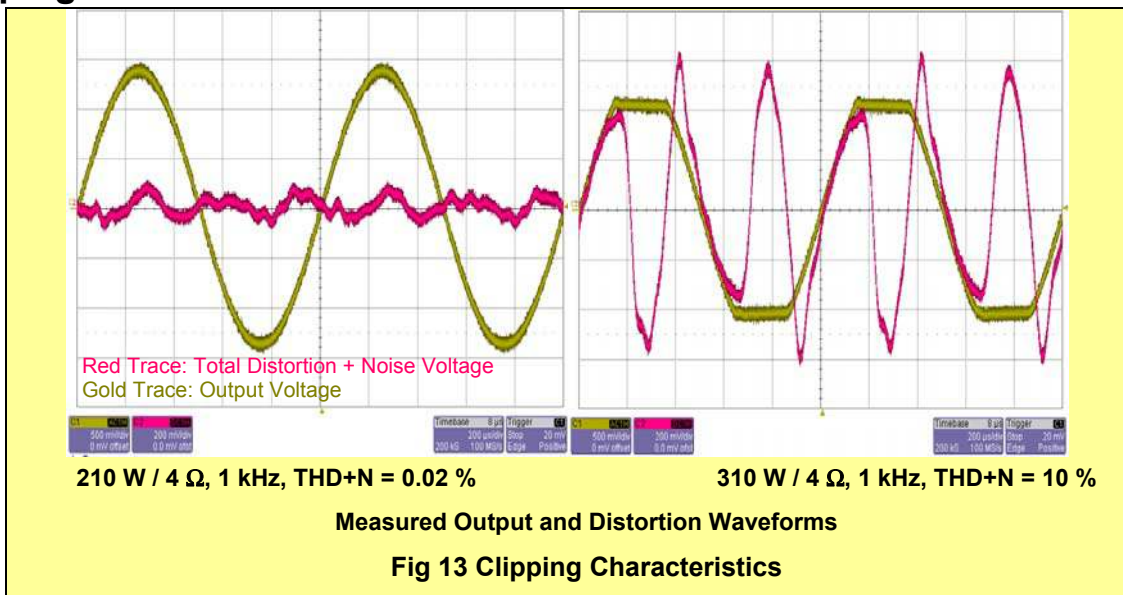

Efficiency

Figs 14-19 show efficiency characteristics of the IRAUDAMP7S. The high efficiency is achieved by following major factors:

- 1) Low conduction loss due to the dual FETs offering low $R_{DS(ON)}$
- 2) Low switching loss due to the dual FETs offering low input capacitance for fast rise and fall times
- 3) Secure dead-time provided by the IRS2092, avoiding cross-conduction

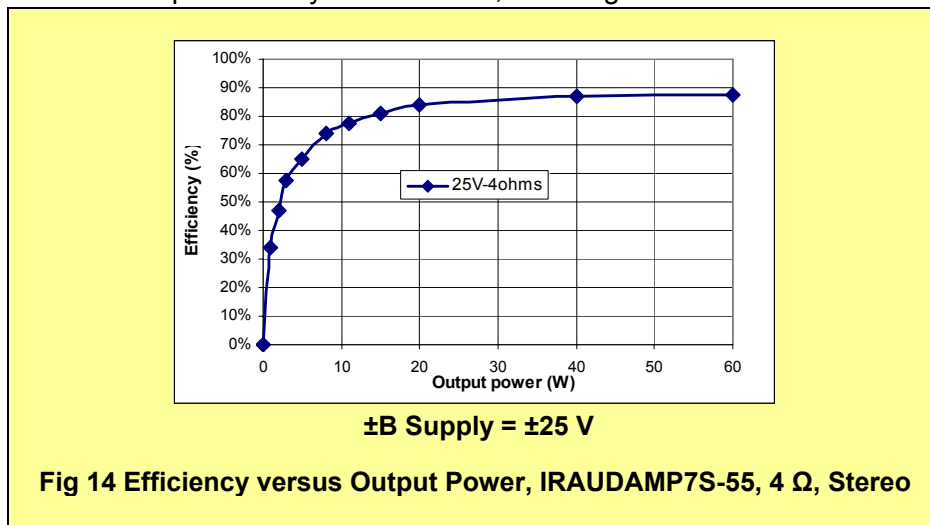

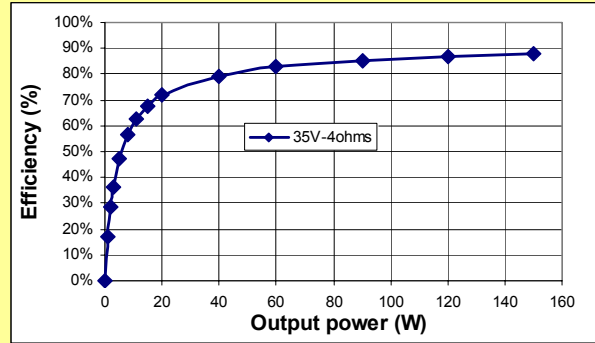

$\pm B$ Supply = ± 35 V

Fig 15 Efficiency versus Output Power, IRAUDAMP7S-100, 4 Ω , Stereo

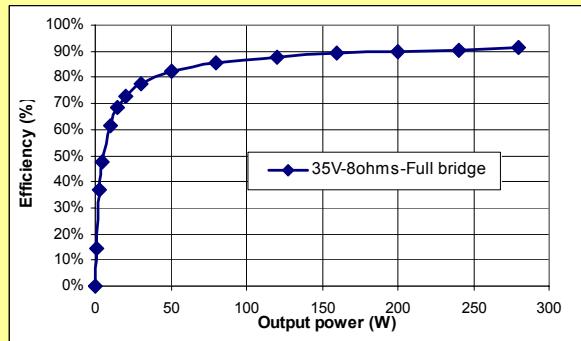

$\pm B$ Supply = ± 35 V

Fig 16 Efficiency versus Output Power, IRAUDAMP7S-100, 8 Ω , Bridged

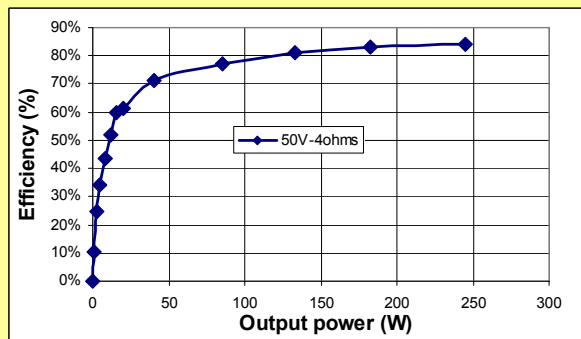

$\pm B$ Supply = ± 50 V

Fig 17 Efficiency versus Output Power, IRAUDAMP7S-150, 4 Ω , Stereo

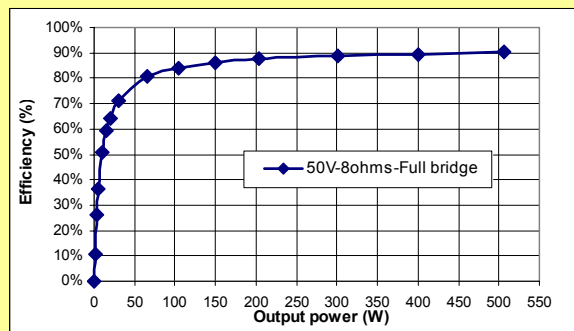

$\pm B$ Supply = $\pm 50V$

Fig 18 Efficiency versus Output Power, IRAUDAMP7S-150, 8 Ω , Bridged

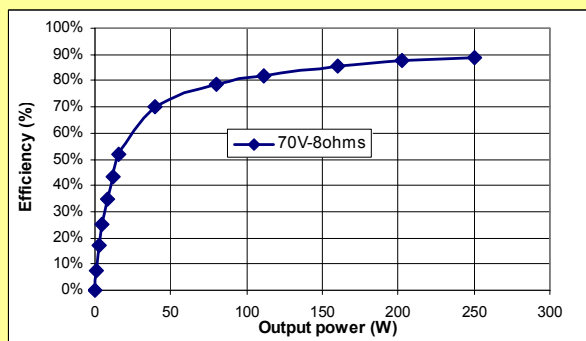

$\pm B$ supply = $\pm 70V$

Fig 19 Efficiency versus Output Power, IRAUDAMP7S-200, 8 Ω , Stereo

Thermal Considerations

With this high efficiency, the IRAUDAMP7S design can handle one-eighth of the continuous rated power, which is generally considered to be a normal operating condition for safety standards, without additional heatsink or forced air-cooling.

Power Supply Rejection Ratio (PSRR)

The IRAUDAMP7S obtains good power supply rejection ratio of -65 dB at 1kHz shown in Fig 20. With this high PSRR, IRAUDAMP7S accepts any power supply topology as far as the supply voltages fit in the min and max range.

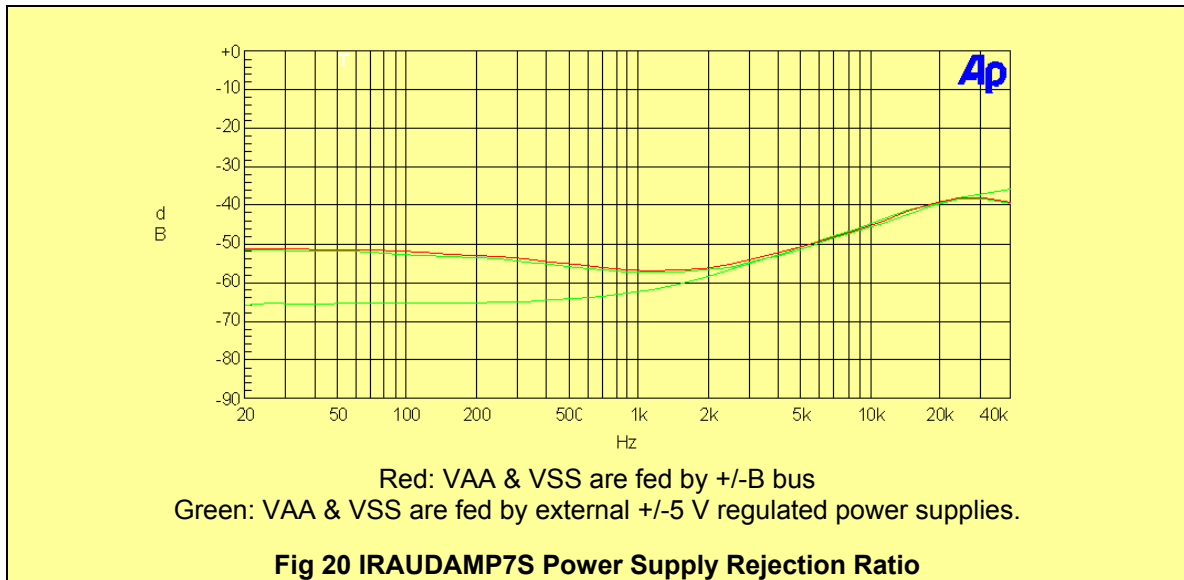

Short Circuit Protection Response

Figs 21-23 show over current protection reaction time of the IRAUDAMP7S in a short circuit event. As soon as the IRS2092 detects over current condition, it shuts down PWM. After one second, the IRS2092 tries to resume the PWM. If the short circuit persists, the IRS2092 repeats try and fail sequences until the short circuit is removed.

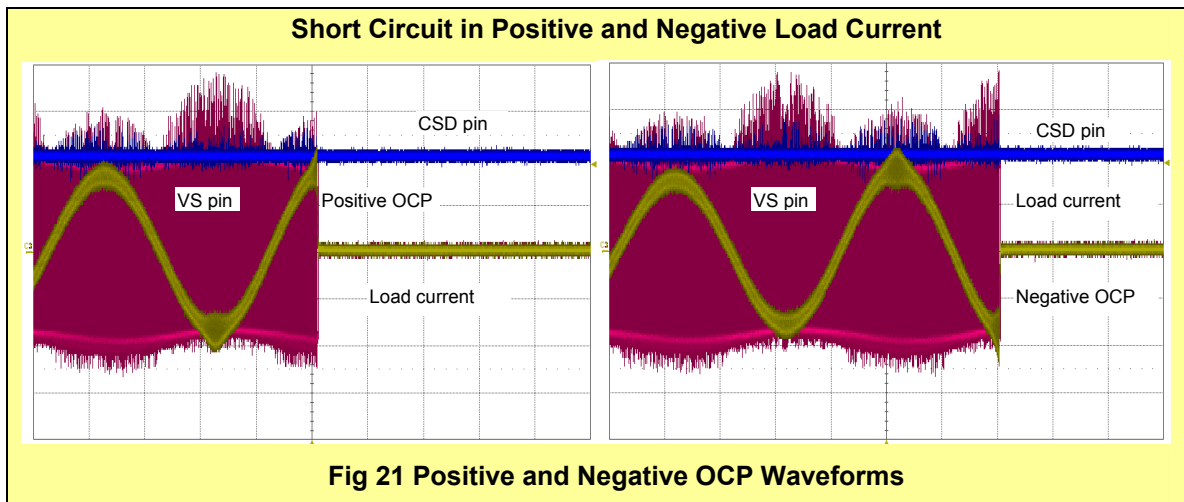

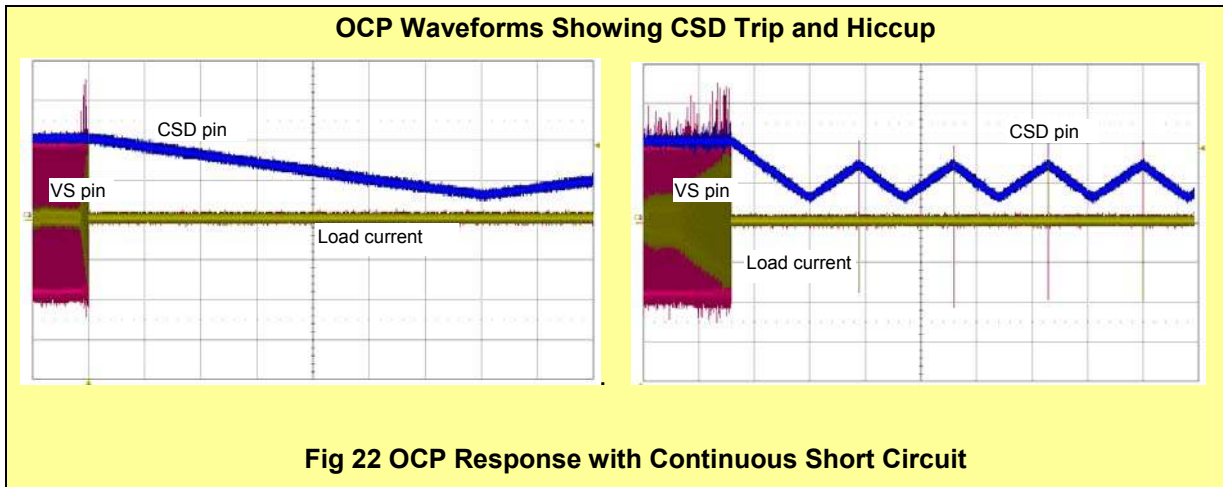

Actual Reaction Time

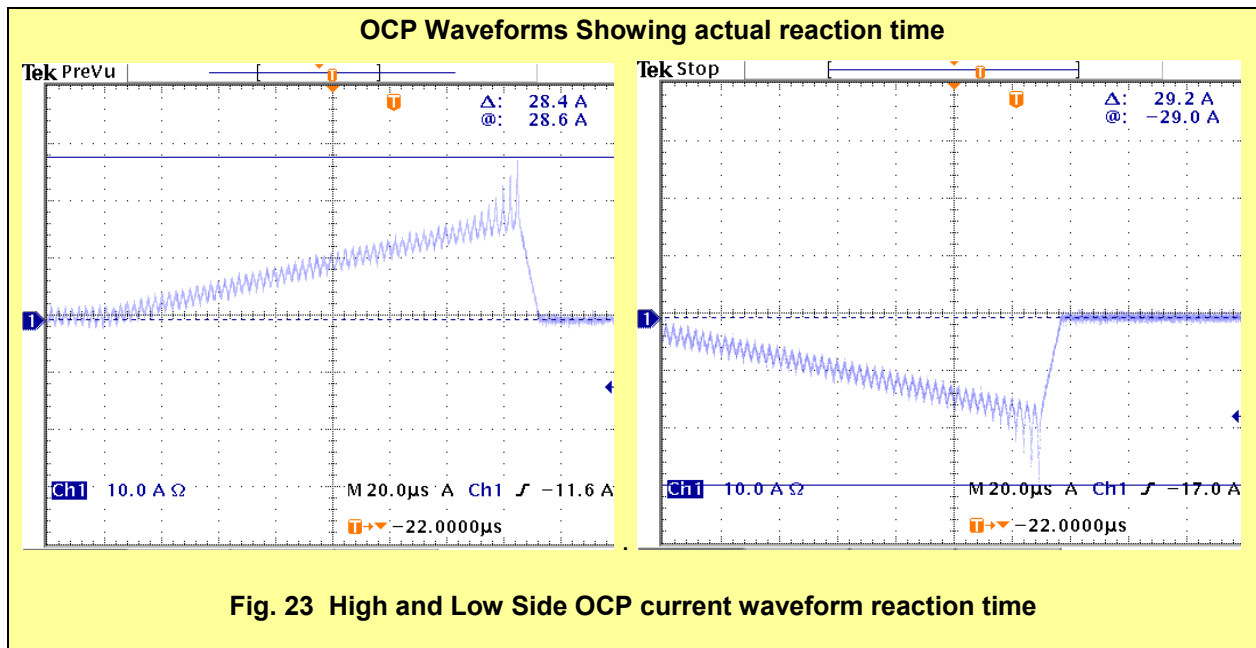

IRAUDAMP7S Overview

The IRAUDAMP7S features a self-oscillating type PWM modulator for the lowest component count, highest performance and robust design. This topology represents an analog version of a second-order sigma-delta modulation having a Class D switching stage inside the loop. The

benefit of the sigma-delta modulation, in comparison to the carrier-signal based modulation, is that all the error in the audible frequency range is shifted to the inaudible upper-frequency range by nature of its operation. Also, sigma-delta modulation allows a designer to apply a sufficient amount of error correction.

The IRAUDAMP7S self-oscillating topology consists of following essential functional blocks.

- Front-end integrator
- PWM comparator
- Level shifters
- Gate drivers and MOSFETs
- Output LPF

Integrator

Referring to Fig 24 below, the input operational amplifier of the IRS2092 forms a front-end second-order integrator with R7, C4, C6, P1, and R11. The integrator that receives a rectangular feedback signal from the PWM output via R8 and audio input signal via R7 generates quadratic carrier signal in COMP pin. The analog input signal shifts the average value of the quadratic waveform such that the duty cycle varies according to the instantaneous voltage of the analog input signal.

PWM Comparator

The carrier signal in COMP pin is converted to PWM signal by an internal comparator that has threshold at middle point between VAA and VSS. The comparator has no hysteresis in its input threshold.

Level Shifters

The internal input level-shifter transfers the PWM signal down to the low-side gate driver section. The gate driver section has another level-shifter that level shifts up the high-side gate signal to the high-side gate driver section.

Gate Drivers and MOSFETs

The received PWM signal is sent to the dead-time generation block where a programmable amount of dead time is added into the PWM signal between the two gate output signals of LO and HO to prevent potential cross conduction across the output power MOSFETs. The high-side level-shifter shifts up the high-side gate drive signal out of the dead-time block.

The IRS2092 drives two MOSFETs, high- and low-sides, in the power stage providing the amplified PWM waveform.

Output LPF

The amplified PWM output is reconstructed back to analog signal by the output LC LPF. Demodulation LC low-pass filter (LPF) formed by L1 and C12, filters out the Class D switching carrier signal leaving the audio output at the speaker load. A single stage output filter can be used with switching frequencies of 400 kHz and greater; a design with a lower switching frequency may require an additional stage of LPF.

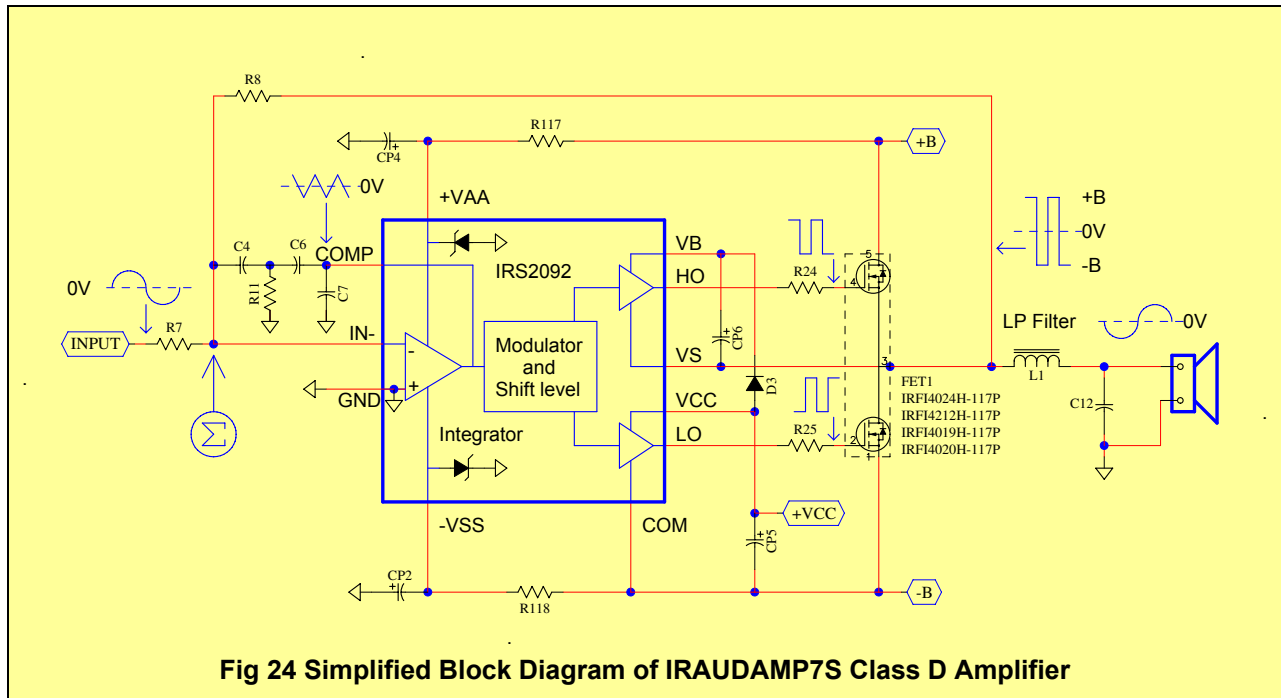

Functional Descriptions

IRS2092 Gate Driver IC

The IRAUDAMP7S uses IRS2092, a high-voltage (up to 200 V), high-speed power MOSFET driver with internal dead-time and protection functions specifically designed for Class D audio amplifier applications. These functions include OCP and UVP. The IRS2092 integrates bi-directional over current protection for both high-side and low-side MOSFETs. The dead-time can be selected for optimized performance according to the size of the MOSFET, minimizing dead-time while preventing shoot-through. As a result, there is no gate-timing adjustment required externally. Selectable dead-time through the DT pin voltage is an easy and reliable function which requires only two external resistors, R26 and R27 as shown on Fig 25 below.

The IRS2092 offers the following functions.

- PWM modulator
- Dead-time insertion
- Over current protection
- Under voltage protection
- Level shifters

Refer to IRS2092 datasheet and AN-1138 for more details.

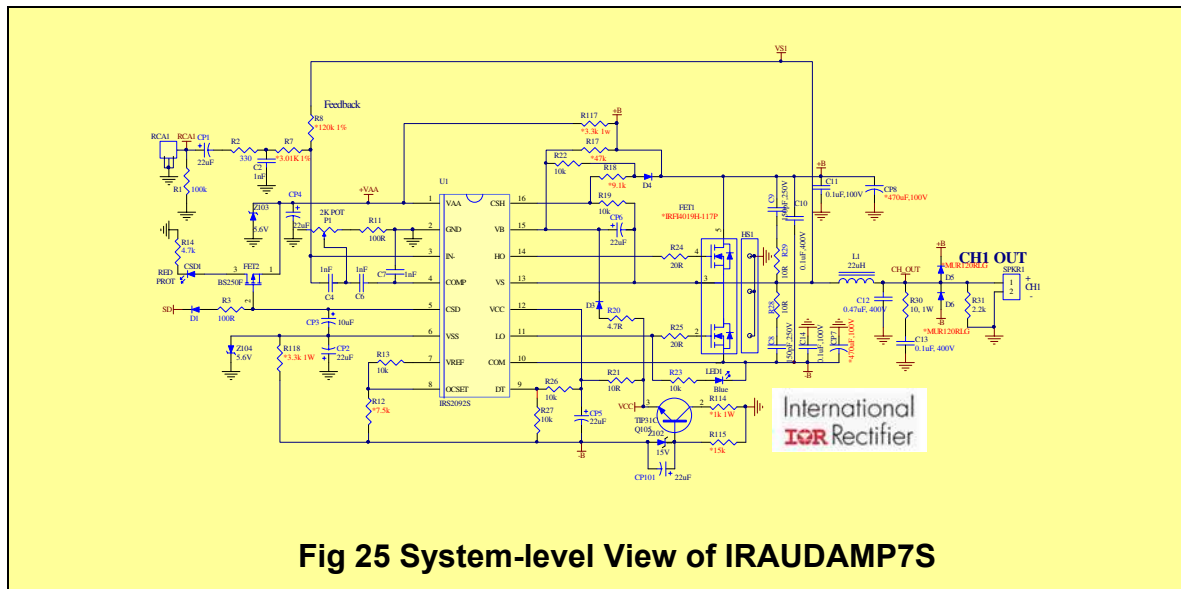

Self-Oscillating Frequency

Self-oscillating frequency is determined by the total delay time along the control loop of the system; the propagation delay of the IRS2092, the MOSFETs switching speed, the time-constant of front-end integrator (P1, R7, R11 R8, C4, C6, C7). Variations in +B and –B supply voltages also affect the self-oscillating frequency.

The self-oscillating frequency changes with the duty ratio. The frequency is highest at idling. It drops as duty cycle varies away from 50%.

Adjustments of Self-Oscillating Frequency

Use P1 & R11 to set different self-oscillating frequencies. The PWM switching frequency in this type of self-oscillating switching scheme greatly impacts the audio performance, both in absolute frequency and frequency relative to the other channels. In the absolute terms, at higher frequencies distortion due to switching-time becomes significant, while at lower frequencies, the bandwidth of the amplifier suffers. In relative terms, interference between channels is most significant if the relative frequency difference is within the audible range.

Normally, when adjusting the self-oscillating frequency of the different channels, it is suggested to either match the frequencies accurately, or have them separated by at least 25kHz. Under the normal operating condition with no audio input signal, the switching-frequency is set around 400kHz in the IRAUDAMP7S.

Selectable Dead-time

The dead-time of the IRS2092 is set based on the voltage applied to the DT pin. Fig 26 lists the suggested component value for each programmable dead-time between 25 and 105 ns. All the IRAUDAMP7S models use DT2 (45ns) dead-time.

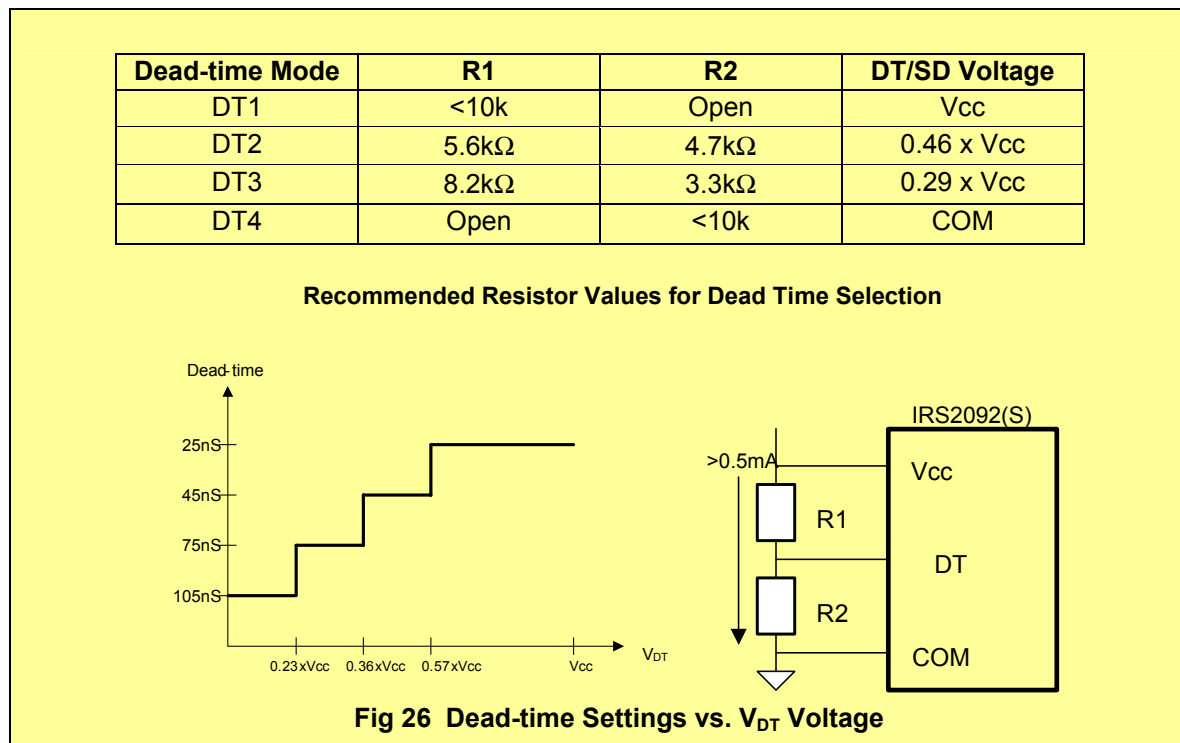

Protection System Overview

The IRS2092 integrates over current protection (OCP) inside the IC. The rest of the protections, such as over-voltage protection (OVP), under-voltage protection (UVP), speaker DC offset protection (DCP) and over temperature protection (OTP), are realized externally to the IRS2092 (Fig 27).

In the event that any of these external fault conditions are detected, the external shutdown circuit will disable the output by pulling down CSD pins, turning on red LEDs, and turning off blue LEDs (Fig 28). If the fault condition persists, the protection circuit stays in shutdown until the fault is removed. Once the fault is cleared, the blue LEDs turn on and red LEDs turn off.

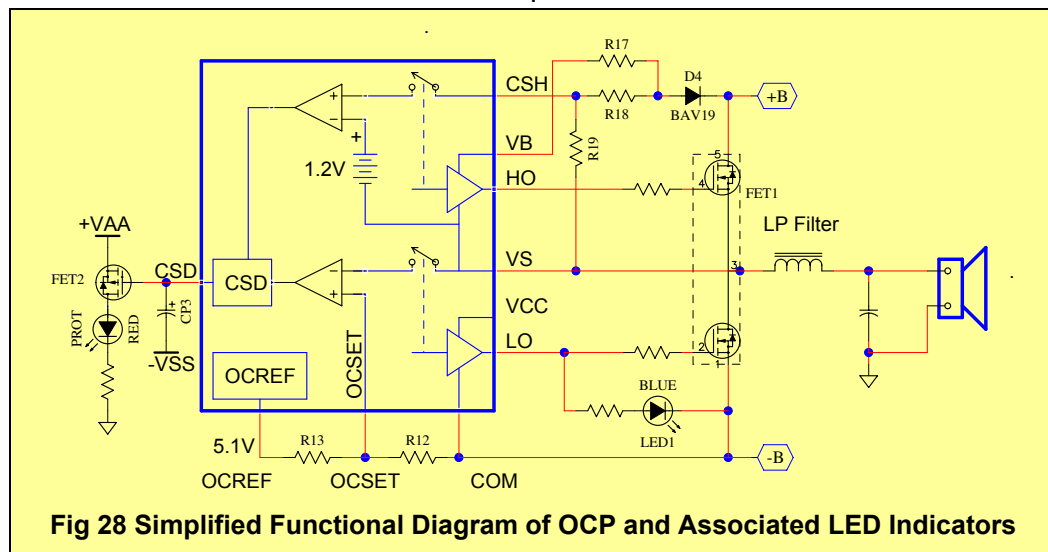
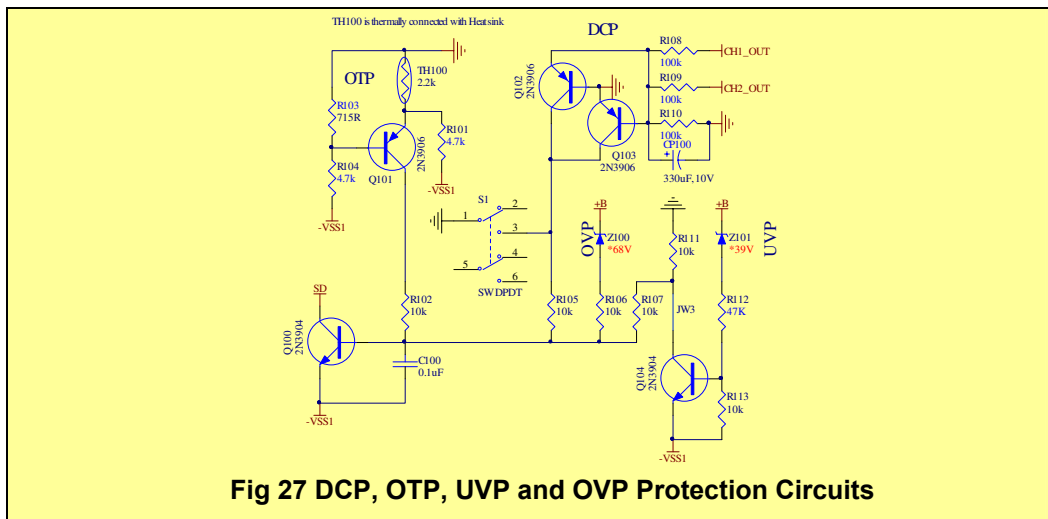

Over-Current Protection (OCP)

Low-Side Current Sensing

The low-side current sensing feature protects the low side MOSFET from an overload condition in negative load current by measuring drain-to-source voltage across $R_{DS(ON)}$ during its on state. OCP shuts down the switching operation if the drain-to-source voltage exceeds a preset trip level.

The voltage setting on the OCSET pin programs the threshold for low-side over-current sensing. When the VS voltage during low-side conduction gets higher than the OCSET voltage, the IRS2092 turns off outputs and pulls CSD down to -VSS.

High-Side Current Sensing

The high-side current sensing protects the high side MOSFET from an overload condition in positive load current by measuring drain-to-source voltage across $R_{DS(ON)}$ during its on state. OCP shuts down the switching operation if the drain-to-source voltage exceeds a preset trip level.

High-side over-current sensing monitors drain-to-source voltage of the high-side MOSFET while it is in the on state through the CSH and VS pins. The CSH pin detects the drain voltage with reference to the VS pin, which is the source of the high-side MOSFET. In contrast to the low-side current sensing, the threshold of CSH pin to trigger OC protection is internally fixed at 1.2V. An external resistive divider R19, R18 and R17 are used to program a threshold as shown in Fig 26. An external reverse blocking diode D4 is required to block high voltage feeding into the CSH pin during low-side conduction. By subtracting a forward voltage drop of 0.6V at D4, the minimum threshold which can be set for the high-side is 0.6V across the drain-to-source.

Table 2 Actual OCP table setting thresholds

Function	Device	Amp7-55	Amp7-100	Amp7-150	Amp7-200
OCSET	R12A R12B	1.3K	3.9K	7.5K	5.1K
Tested OCP current 25°C			23A	30A	23A
CSH	R18A R18B	0.0	4.7K	9.1K	8.2K
Tested OCP current 25°C			23A	29A	23A
Peak load current at rated power		6.0A	8.7A	12.2A	8.9A

Over-Voltage Protection (OVP)

OVP is provided externally to the IRS2092. OVP shuts down the amplifier if the bus voltage between GND and +B exceeds 75V. The threshold is determined by a Zener diode Z100. OVP

protects the board from harmful excessive supply voltages, such as due to bus pumping at very low frequency continuous output in stereo mode.

Under-Voltage Protection (UVP)

UVP is provided externally to the IRS2092. UVP prevents unwanted audible noise output from unstable PWM operation during power up and down. UVP shuts down the amplifier if the bus voltage between GND and +B falls below a voltage set by Zener diode Z101.

Speaker DC-Voltage Protection (DCP)

DCP protects speakers against DC output current feeding to its voice coil. DC offset detection detects abnormal DC offset and shuts down PWM. If this abnormal condition is caused by a MOSFET failure because one of the high-side or low-side MOSFETs short circuited and remained in the on state, the power supply needs to be cut off in order to protect the speakers. Output DC offset greater than $\pm 4V$ triggers DCP.

Offset Null (DC Offset) Adjustment

The IRAUDAMP7S requires no output-offset adjustment. DC offsets are tested to be less than ± 20 mV.

Over-Temperature Protection (OTP)

A NTC resistor, TH100 in Fig 25, is placed in close proximity to two dual MOSFETs on a heatsink to monitor heatsink temperature. If the heatsink temperature rises above $100\text{ }^{\circ}\text{C}$, the OTP shuts down both channels by pulling down CSD pins of the IRS2092. OTP recovers once the temperature has cooled down.

ON-OFF Switch

OFF position of S1 forces the IRAUDAMP7S to stay in shutdown mode by pulling down the CSD pin. During the shutdown mode the output MOSFETs are kept off.

Click and POP Noise Reduction

Thanks to the click and pop elimination function built into the IRS2092, IRAUDAMP7S does not use any additional components for this function.

Power Supply Requirements

For convenience, the IRAUDAMP7S has all the necessary housekeeping power supplies onboard and only requires a pair of symmetric power supplies. Power supply voltage depends on the model and is shown in the power selection in Table 1.

House Keeping Power Supply

The internally-generated housekeeping power supplies include $\pm 5.6V$ for analog signal processing, and +12V supply (V_{CC}) referred to negative supply rail -B for MOSFET gate drive. The VAA and VSS supplying floating input section are fed from +B and -B power stage bus supplies via R117 and R118, respectively. Gate driver section of IRS2092 uses V_{CC} to drive gates of MOSFETs. The V_{CC} is referenced to -B (negative power supply). D3 and CP6 form a bootstrap floating supply for the HO gate driver.

Bus Pumping

When the IRAUDAMP7S is running in the stereo mode, bus pumping effect takes place with low frequency high output. Since the energy flowing in the Class D switching stage is bi-directional, there is a period where the Class D amplifier feeds energy back to the power supply. The majority of the energy flowing back to the supply is from the energy stored in the inductor in the output LPF. Usually, the power supply has no way to absorb the energy coming back from the load. Consequently the bus voltage is pumped up, creating bus voltage fluctuations.

Following conditions make bus pumping worse:

1. Lower output frequencies (bus-pumping duration is longer per half cycle)
2. Higher power output voltage and/or lower load impedance (more energy transfers between supplies)
3. Smaller bus capacitance (the same energy will cause a larger voltage increase)

The OVP protects IRAUDAMP7S from failure in case of excessive bus pumping. One of the easiest counter measures of bus pumping is to drive both of the channels in a stereo configuration out-of-phase so that one channel consumes the energy flow from the other and does not return it to the power supply. Bus voltage detection monitors only +B supply, assuming the bus pumping on the supplies is symmetric in +B and -B supplies.

There is no bus pumping effect in full bridge mode.

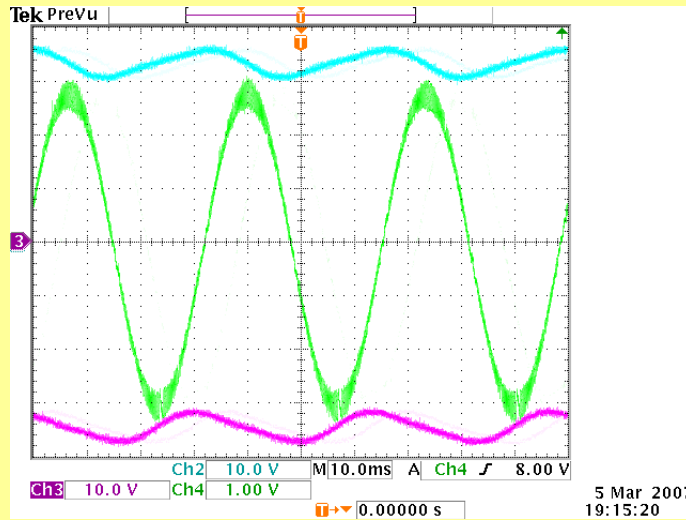

Cyan: Positive Rail voltage (+B), Green: Speaker Output, Pink: Negative Rail voltage (-B)

Fig 29 Bus Pumping in Half Bridge Mode

Bridged Configuration

By selecting S300 to Bridged position, the IRAUDAMP7S realizes full bridge mode, also known as bridge-tied-load, or BTL configuration. Full bridge operation is achieved by feeding out-of-phase audio input signals to the two input channels as shown in the Fig 30 below.

In bridged mode, IRAUDAMP7S receives audio input signal from channel A only. The on-board inverter feed out-of-phase signal to Channel B. The speaker output must be connected between (+) of Channel A and (+) of Channel B in bridged mode.

In bridged mode, nominal load impedance is 8 Ω. (See power table in Table 1)

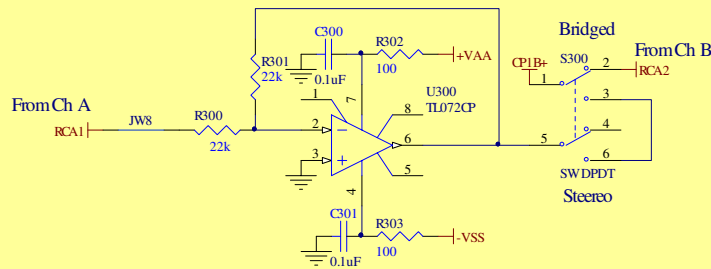

Fig 30 Bridged Configuration (BTL)

Load Impedance

Each channel is optimized for a 4 Ω speaker load in half bridge and 8 Ω load in full bridge.

Output Filter Selection

Since the output filter is not included in the control loop of the IRAUDAMP7S, the control loop has no ability to compensate performance deterioration caused by the output filter. Therefore, it is necessary to understand what characteristics are preferable when designing the output filter.

- 1) The DC resistance of the inductor should be minimized to 20 m Ω or less.
- 2) The linearity of the output inductor and capacitor should be high with output current and voltage.

Fig 31 demonstrates THD performance difference with various inductors.

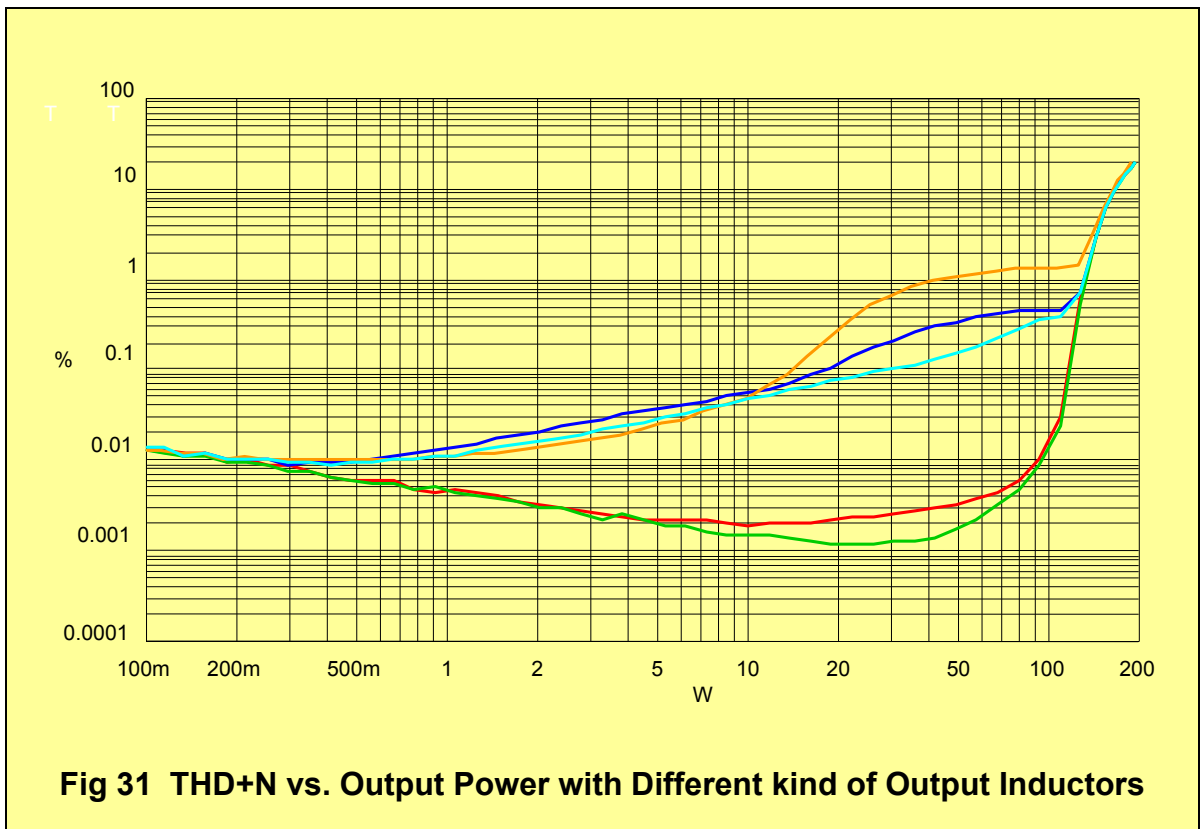

Input Signal and Gain Setting

A proper input signal is an analog signal ranging from 20Hz to 20kHz with up to 3 V_{RMS} amplitude with a source impedance of no more than 600 Ω . Input signal with frequencies from 30kHz to 60kHz may cause LC resonance in the output LPF, causing a large reactive current flowing through the switching stage, especially with greater than 8 Ω load impedances, and the LC resonance can activate OCP.

The IRAUDAMP7S has an RC network called Zobel network (R30 and C13) to damp the resonance and prevent peaking frequency response with light loading impedance. (Fig 32) The Zobel network is not thermally rated to handle continuous supersonic frequencies above 20kHz. These supersonic input frequencies can be filtered out by adding R2 and C2 as shown on main schematic Fig 33 and Fig 34. This RC filter works also as an input RF filter to prevent potential radio frequency interferences.

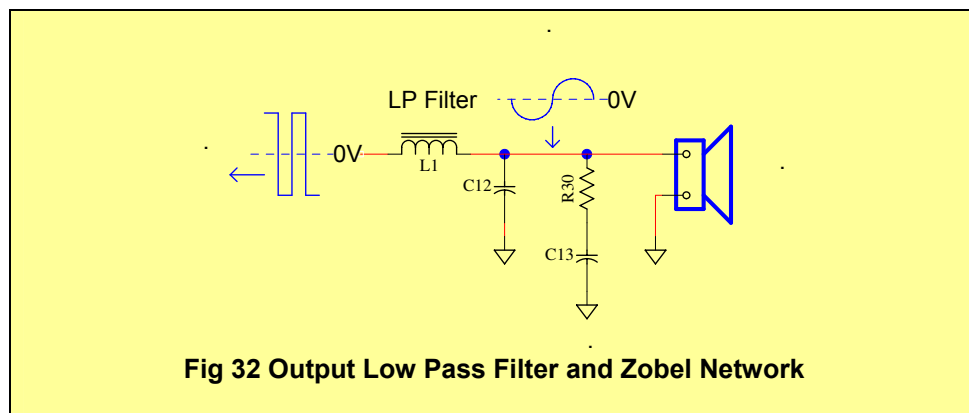

Gain Setting

The ratio of resistors R8/R2 in Fig 33 sets voltage gain. The IRAUDAMP7S has no on board volume control. To change the voltage gain, change the input resistor term R2. Changing R8 affects PWM control loop design and may result poor audio performance.

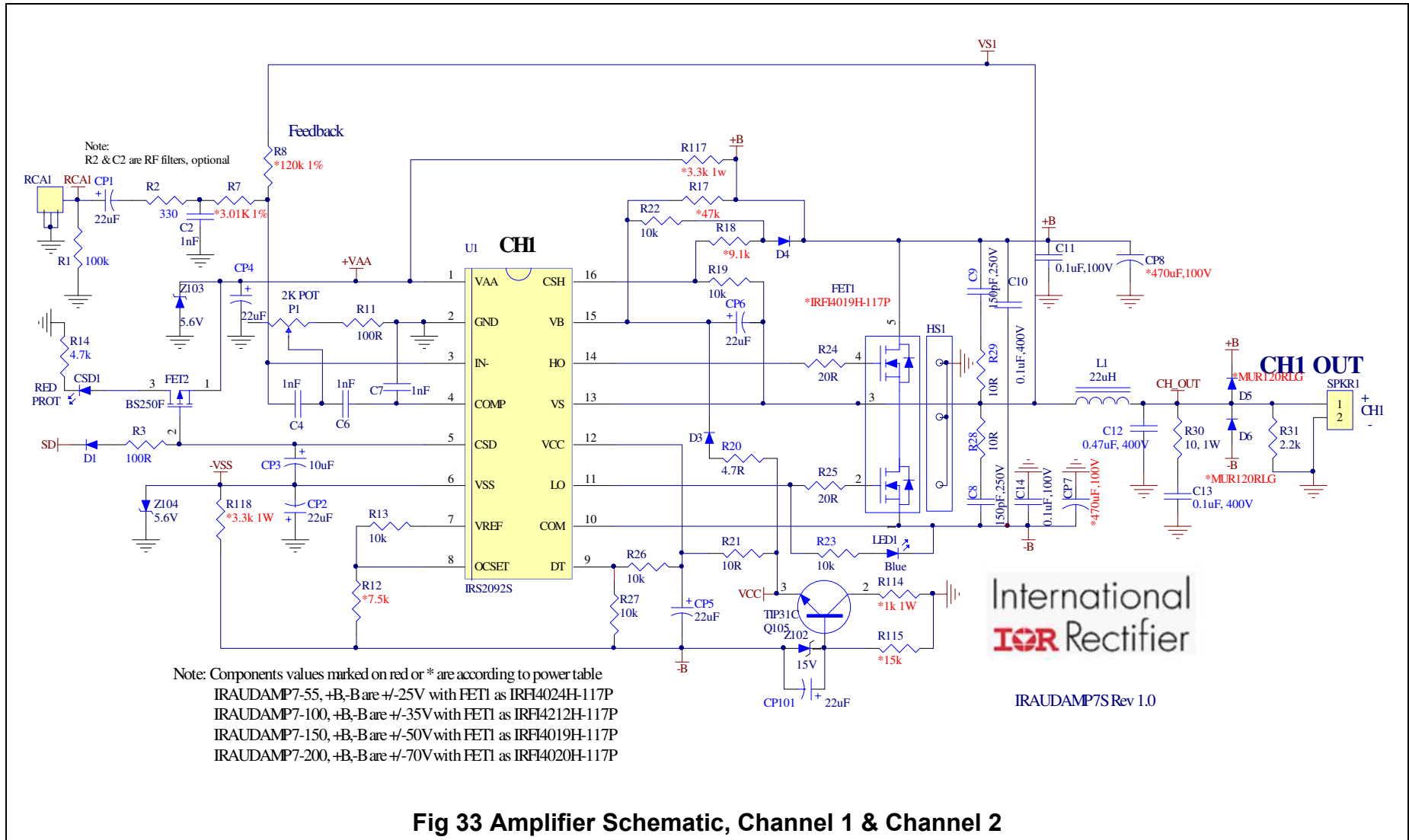

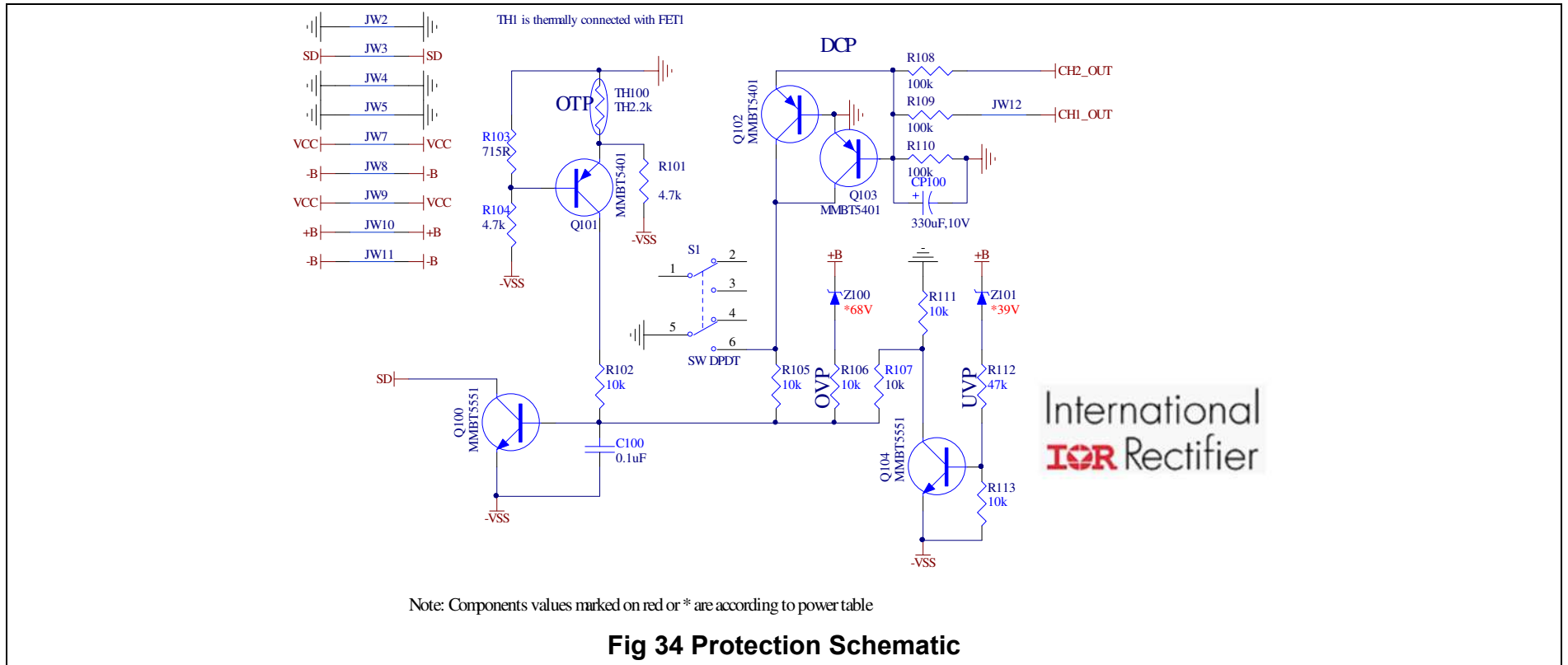

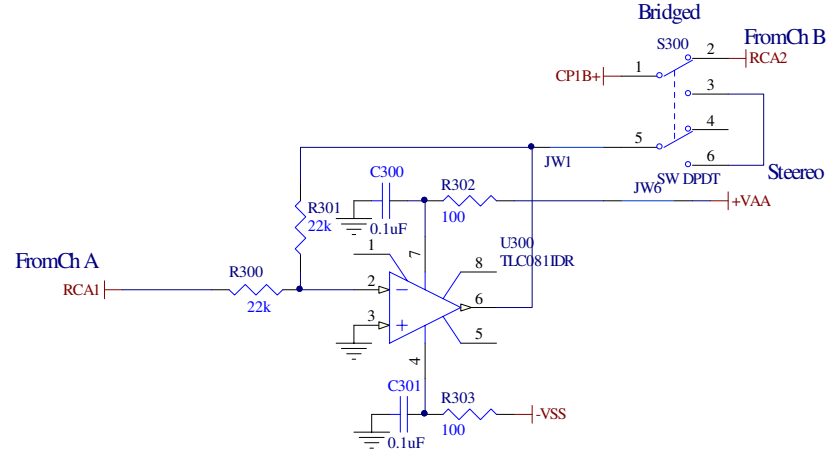

Fig 35 Bridge Preamp Schematic

IRAUDAMP7S-150 Fabrication Materials

Table 3 IRAUDAMP7S-150 Electrical Bill of Materials

Quantity	Value	Description	Designator	Digikey P/N	Vendor
8	1nF,250V	CAP CER 1000PF 250V C0G 5%	C2A, C2B, C4A, C4B, C6A, C6B, C7A, C7B	445-2325-1-ND	TDK Corporation
4	150pF,250V	CAP CER 150PF 250V U2J	C8A, C8B, C9A, C9B	490-5025-1-ND	Murata Electronics
4	0.1uF,400V	CAP .10UF 400V METAL POLYPRO	C10A, C10B, C13A, C13B	495-1311-ND	EPCOS Inc
4	0.1uF,100V	CAP .10UF 100V CERAMIC X7R	C11A, C11B, C14A, C14B	PCC2239CT-ND	Panasonic - ECG
2	0.47uF, 400V	CAP .47UF 400V METAL POLYPRO	C12A, C12B	495-1315-ND	EPCOS Inc
3	0.1uF, 10V	CAP CER 0.1UF 10V SL 5%	C100, C300, C301	445-2686-1-ND	TDK Corporation
1	ED365/3	TERMINAL BLOCK 7.50MM 3POS PCB	CONN1	ED2355-ND	On Shore Technology Inc
12	22uF	CAP 22UF 25V ELECT VR RADIAL	CP1A, CP1B, CP2A, CP2B, CP4A, CP4B, CP5A, CP5B, CP6A, CP6B, CP101A, CP101B	493-1058-ND	Nichicon
2	10uF, 16V	CAP ELECT 10UF 16V KS RADIAL	CP3A, CP3B	P966-ND	Panasonic - ECG
4	470uF,100V	CAP 470UF 100V ELECT PW RADIAL	CP7A, CP7B, CP8A, CP8B	493-1985-ND	Nichicon
1	330uF, 10V	CAP 330UF 10V ALUM LYTIC RADIAL	CP100	P5125-ND	Panasonic - ECG
2	Red LED	LED 3MM HI-EFF RED TRANSPARENT	CSD1A, CSD1B	160-1140-ND	Lite-On Inc
2	1N4148WS	DIODE SWITCH 75V 200MW	D1A, D1B	1N4148WS-FDICT-ND	Diodes Inc
2	MURA120T3G	DIODE ULTRA FAST 1A 200V	D3A, D3B	MURA120T3GOSCT-ND	ON Semiconductor
2	BAV19WS	DIODE SWITCH 100V 200MW	D4A, D4B	BAV19WS-FDICT-ND	Diodes Inc
4	MURA120T3G	DIODE ULTRA FAST 1A 200V	D5A, D5B, D6A, D6B	MURA120T3GOSCT-ND	ON Semiconductor
2	IRFI4019H-117P	IRFI4019H-117P, Dual MOSFET TO-220-5	FET1A, FET1B	IR's Part No.	International Rectifier
2	BS250P	MOSFET P-CH 45V 90MA	FET2A, FET2B	BS250FTC-ND	Zetex Inc
1	Heat Sink	Aluminum heat spreader	HS1A	Drawing IRHS_Amp1	Custom made
1	JW-300	Wire Jumper #20 AWG insulated	JW1	Custom	Custom
3	JW-300	Wire Jumper #20 AWG insulated	JW2, JW4, JW10	Custom	Custom
1	JW-1500	Wire Jumper #20 AWG insulated	JW3	Custom	Custom
1	JW-1500	Wire Jumper #20 AWG insulated	JW5	Custom	Custom
2	JW-1800	Wire Jumper #20 AWG insulated	JW6, JW7	Custom	Custom
2	JW-2000	Wire Jumper #20 AWG insulated	JW8, JW9	Custom	Custom
2	22uH, 13A	Class D Inductor, 22UH	L1A, L1B	Sagami 7G17A-220M-R or IN09063	Inductors, Inc. or ICE Components, Inc.
2	Blue LED	LED 3MM DUAL FLANGE BLUE CLEAR	LED1A, LED1B	160-1600-ND	LITE-ON INC
2	2K POT	POTENTIOMETER	P1A, P1B	3362H-202LF-ND	Bourns Inc.
2	MMBT5551	TRANSISTOR NPN 160V	Q100, Q104	MMBT5551FSCT-ND	Fairchild Semiconductor

3	MMBT5401	TRANS PNP 150V 350MW SMD	Q101, Q102, Q103	MMBT5401-FDICT-ND	Diodes Inc
2	TIP31C	TRANSISTOR NPN 100V 3A	Q105A, Q105B	497-2615-5-ND	STMicroelectronics
3	100k	RES 100K OHM 1/8W 5%	R1A, R1B, R110	RHM100KARCT-ND	Rohm
1	330	RES 330 OHM 1/8W 1%	R2A	RHM330CRCT-ND	Rohm
1	330	RES 330 OHM CARBON FILM	R2B	P330BACT-ND	Panasonic - ECG
2	100R	RES 100 OHM 1/8W 5%	R3A, R3B	P100ACT-ND	Panasonic - ECG
2	3.01K	RES 3.01K OHM 1/8W 1%	R7A, R7B	RHM3.01KCCT-ND	Rohm
2	120k 1%	RES METAL FILM 120K OHM 1/4W	R8A, R8B	P120KCACT-ND	Panasonic - ECG
2	100R	RES 100 OHM 1/8W 5%	R11A, R11B	RHM100ARCT-ND	Rohm
2	7.5k	RES 7.5K OHM 1/8W 5%	R12A, R12B	RHM7.5KARCT-ND	Rohm
18	10k	RES 10K OHM 1/8W 5%	R13A, R13B, R19A, R19B, R22A, R22B, R23A, R23B, R26A, R26B, R27A, R27B, R102, R105, R106, R107, R111, R113	RHM10KARCT-ND	Rohm
4	4.7k	RES 4.7K OHM 1/8W 5%	R14A, R14B, R101, R104	RHM4.7KARCT-ND	Rohm
2	47k	RES 47K OHM 1/8W 5%	R17A, R17B	RHM47KARCT-ND	Rohm
2	9.1k	RES 9.1K OHM 1/8W 5%	R18A, R18B	RHM9.1KARCT-ND	Rohm
2	4.7R	RES 4.7 OHM 1/4W 1%	R20A, R20B	P4.7RCT-ND	Panasonic - ECG
2	10R	RES 10.0 OHM 1/4W 1%	R21A, R21B	RHM10.0FRCT-ND	Rohm
4	20R	RES 20.0 OHM 1/8W 1%	R24A, R24B, R25A, R25B	RHM20.0CRCT-ND	Rohm
4	10R	RES 10.0 OHM 1/8W 1%	R28A, R28B, R29A, R29B	RHM10.0CRCT-ND	Rohm
2	10, 1W	RES 10 OHM 1W 5%	R30A, R30B	PT10XCT-ND	Panasonic - ECG
2	2.2k	RES 2.2K OHM 1/4W 5%	R31A, R31B	RHM2.2KERCT-ND	Rohm
1	715R	RES 715 OHM 1/8W 1%	R103	RHM715CCT-ND	Rohm
1	100k	RES 100K OHM 1/8W 5%	R108	RHM100KARCT-ND	Rohm
1	100k	RES 100K OHM CARBON FILM 1/4W 5%	R109	P100KBATB-ND	Panasonic - ECG
1	47k	RES 47K OHM 1/8W 5%	R112	RHM47KARCT-ND	Rohm
2	1k 1W	RES 1.0K OHM 1W 5% METAL OXIDE	R114A, R114B	1.0KW-1-ND	Yageo
2	15k	RES 15K OHM CARBON FILM 1/4W 5%	R115A, R115B	P15KBACT-ND	Panasonic - ECG
4	3.3k 1w	RES 3.3K OHM 1W 5% METAL OXIDE	R117A, R117B, R118A, R118B	3.3KW-1-ND	Yageo
2	22k	RES 22K OHM 1/8W 5%	R300, R301	RHM22KARCT-ND	Rohm
2	100	RES 100 OHM 1/8W 5%	R302, R303	RHM100ARCT-ND	Rohm
2	RCJ-012	CONN RCA JACK METAL R/A RED PCB	RCA1A	CP-1401-ND (Red)	CUI Inc
2	RCJ-013	CONN RCA JACK METAL R/A WHT PCB	RCA1B	CP-1402-ND (White)	CUI Inc
2	EG2209A	SWITCH SLIDE DPDT 12V .1A L=4	S1, S300	EG1908-ND	E-Switch
2	ED365/2	TERMINAL BLOCK 7.50MM 2POS PCB	SPKR1A, SPKR1B	ED2354-ND	On Shore Technology
1	2.2k at 25C	THERMISTOR NTC 2.2K OHM LEADED	TH100	BC2304-ND	Vishay/BC Components
2	IRS2092SPBF	Class D Controller, IRS2092SPbF 16-Lead SOIC	U1A, U1B	IR's P/N	International Rectifier
1	TLC071CD	IC SINGLE SUPPLY OPAMP 8-SOIC	U300	296-2414-5-ND IRS2092SPBF	Texas Instruments
2	15V	DIODE ZENER 500MW 15V	Z102A, Z102B	MMSZ4702T1GOSCT-ND	ON Semiconductor

1	68V	DIODE ZENER 375MW 68V	Z100	568-3782-1-ND	NXP Semiconductors
1	39V	DIODE ZENER 500MW 39V	Z101	BZT52C39-TPMSCT-ND	Micro Commercial Co
4	5.6V	DIODE ZENER 500MW 5.6V	Z103A, Z103B, Z104A, Z104B	BZT52C5V6-TPMSCT-ND	Micro Commercial Co
Note all ½ W and 1W resistors are flame proof part numbers					

Table 4 IRAUDAMP7S Mechanical Bill of Materials

Quantity	Value	Description	Designator	Digikey P/N	Vendor
5	Washer #4 SS	WASHER LOCK INTERNAL #4 SS	Lock washer 1, Lock washer 2, Lock washer 3, Lock washer 4, Lock washer 5	H729-ND	Building Fasteners
1	PCB	Print Circuit Board IRAUDAMP7S_Rev 2.2 .PCB	PCB 1		Custom
12	Screw 4-40X5/16	SCREW MACHINE PHILLIPS 4-40X5/16	Screw 1, Screw 2, Screw 3, Screw 4, Screw 5, Screw 6, Screw 7, Screw 8, Screw 9, Screw 10, Screw 11, Screw 12	H343-ND	Building Fasteners
4	Stand off 0.5"	STANDOFF HEX 4-40THR .500"L ALUM	Stand Off 1, Stand Off 2, Stand Off 3, Stand Off 4	1893K-ND	Keystone Electronics
1	Stand off 0.5"	STANDOFF HEX M/F 4-40 .500" ALUM, Chassis GND	Stand Off 5	8401K-ND	Keystone Electronics
1	AAVID 4880G	Thermalloy TO-220 mounting kit with screw	TO-220 mounting kit 1	Newark 82K6096	Thermalloy

Table 5 IRAUDAMP7S Models Differential Table

Item		Model Name				Notes
		AMP7S-55	AMP7S-100	AMP7S-150	AMP7S-200	
IR Power MOSFETS	FET1	IRFI4024H-117P	IRFI4212H-117P	IRFI4019H-117P	IRFI4020H-117P	
Half Bridge Output	8 Ω	25 W x 2	60 W x 2	125 W x 2	250 W x 2	Stereo
	4 Ω	50 W x 2	120 W x 2	250 W x 2	N/A	Stereo
Full Bridge Output	8 Ω	100 W x 1	240 W x 1	500 W x 1	N/A	Bridged
Power Supply	+B, -B	±25 V	±35 V	±50 V	±70 V	
	±B Voltage Range	±3 V	±5 V	±8 V	±10 V	
Audio Gain	Gain	20	30	36	40	
Feedback	R8A,R8B	68k	100k	120k	130 k	
+VAA	R117A* R117B*	1 k, 1 W	2.2 k, 1 W	3.3 k, 1 W	5.1 k, 1 W	
-VSS	R118A* R118B*	1 k, 1 W	2.2 k, 1 W	3.3 k, 1 W	5.1 k, 1 W	
VCC	R114A* R114B*	100, 1 W	220, 1 W	1 k, 1 W	2.2 k 1 W	
	R115A R115B	4.7 k	10 k	15 k	20 k	
OCSET	R12A R12B	1.3 k (20 A)	3.9 k (23 A)	7.5 k (30 A)	5.1 k (23 A)	(Trip level)
CSH	R18A R18B	0.0 (20A)	4.7 k (23A)	9.1 k (29A)	8.2 k (23 A)	(Trip level)
VB	R17A R17B	20 k	33 k	47 k	75 k	
OVP	Z100	24 V BZT52C24-TPMSCT-ND	47 V MMSZ5261BT1GO SCT-ND	68 V 568-3782-1-ND	91 V MMSZ5270BT1G OSCT-ND	Zener Digikey P/N
UVP	Z101	12 V MMSZ5242BT1GO SCT-ND	30 V MMSZ5256BT1GO SCT-ND	39 V BZT52C39-TPMSCT-ND	51 V MMSZ5262BT1G OSCT-ND	Zener Digikey P/N
Clamping Diode	D5A D5B D6A D6B	MURA120T3OSCT-ND	MURA120T3OSCT-ND	IMURA120T3OSCT-ND	N/A	

*** Marked components are axial, ±5 %, ¼ w, and flame proof type.**

IRAUDAMP7S Hardware

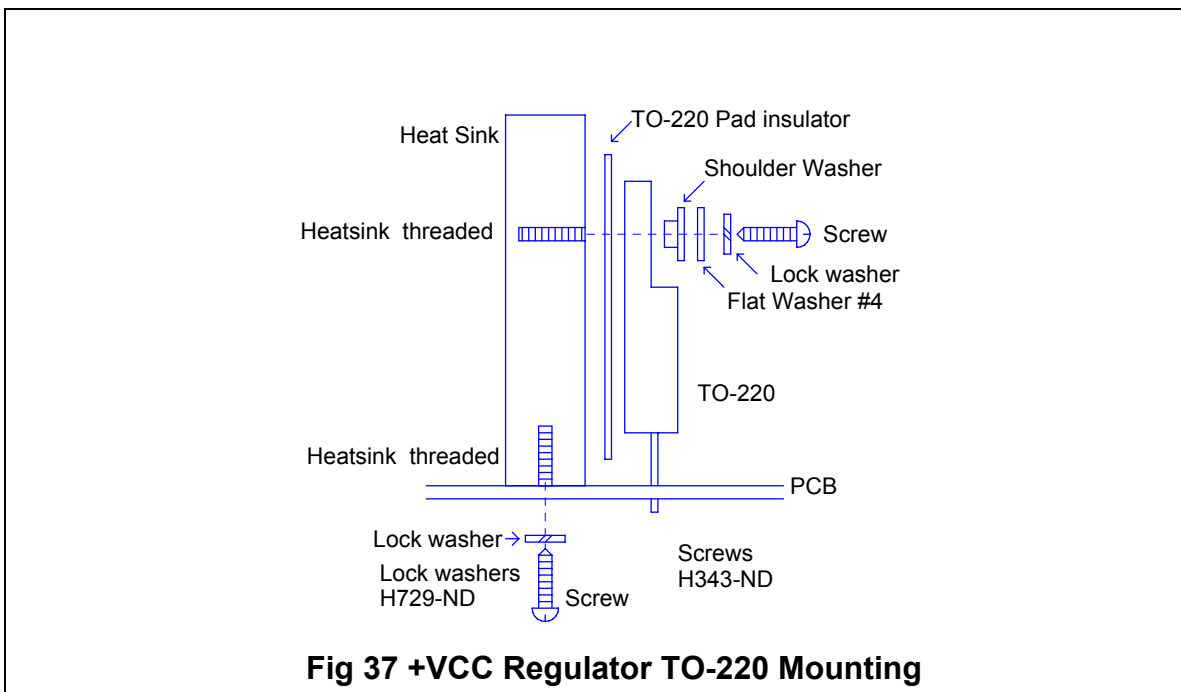
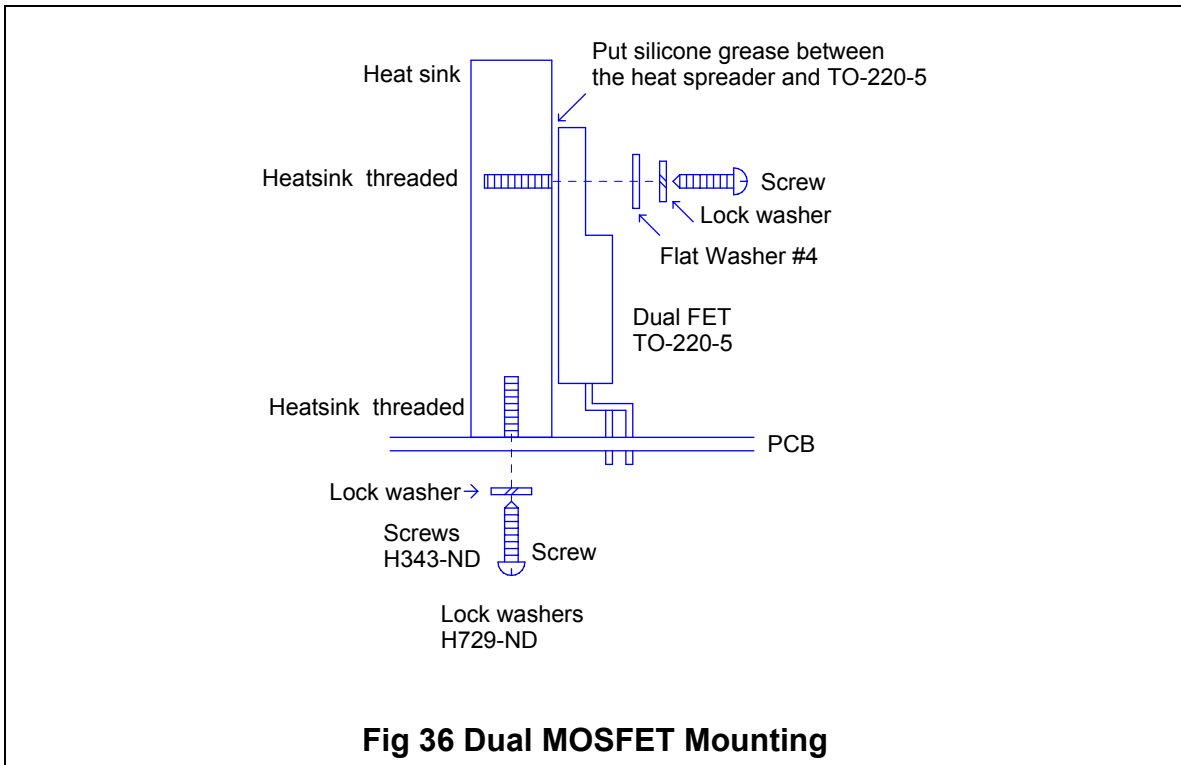

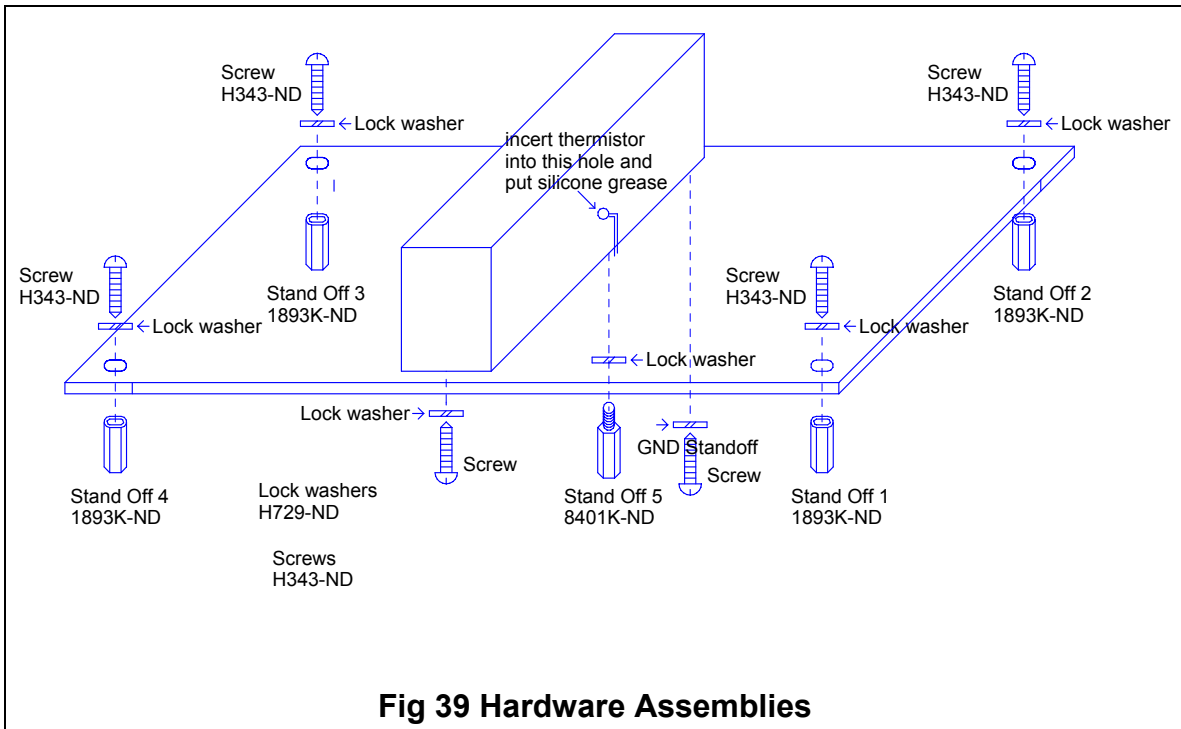
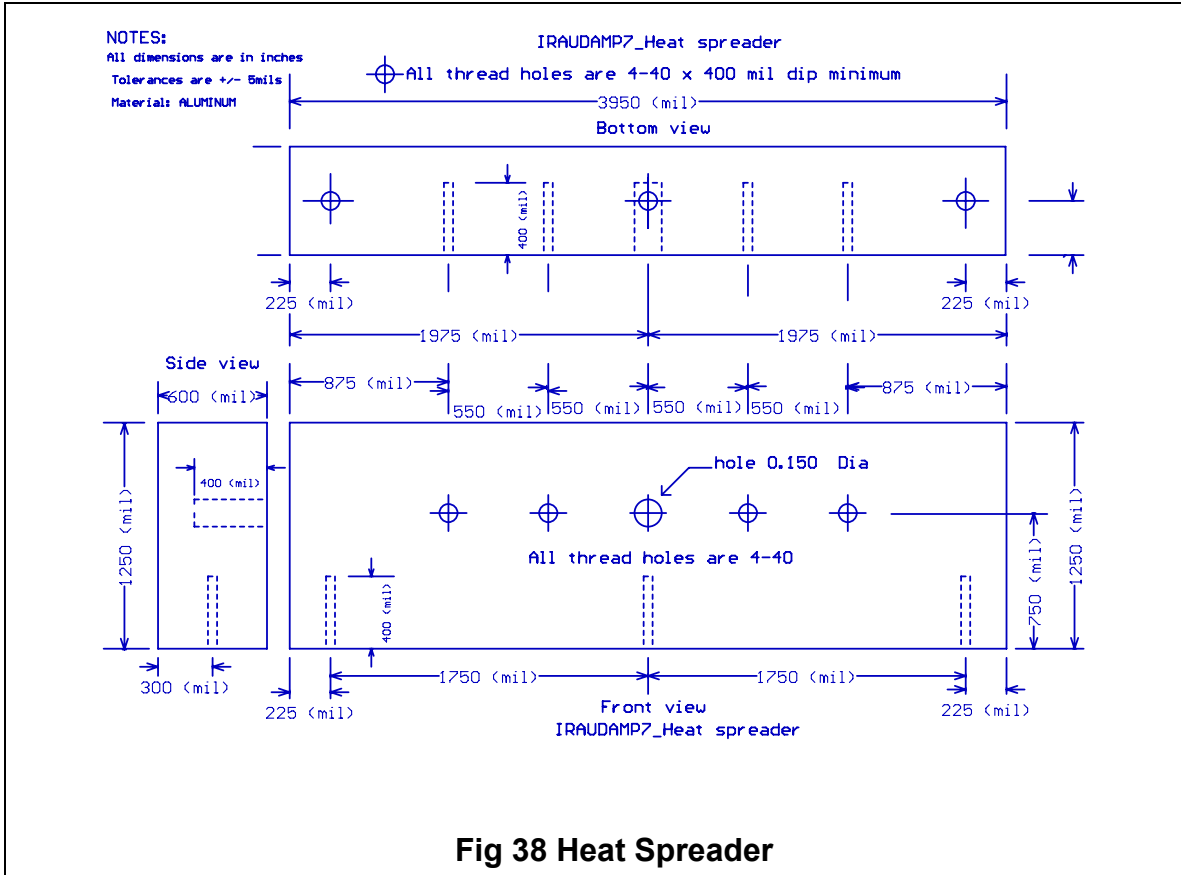

IRAUDAMP7S PCB Specifications

PCB:

1. Single Layers SMT PCB with through holes
2. 1/16 thickness
3. 2/0 OZ Cu
4. FR4 material
5. 10 mil lines and spaces
6. Solder Mask to be Green enamel EMP110 DBG (CARAPACE) or Enthone Endplate DSR-3241 or equivalent.
7. Top Silk Screen to be white epoxy non conductive per IPC-RB 276 Standard.
8. All exposed copper must finished with TIN-LEAD Sn 60 or 63 for 100u inches thick.
9. Tolerance of PCB size shall be 0.010 -0.000 inches
10. Tolerance of all Holes is -.000 + 0.003"
11. PCB acceptance criteria as defined for class II PCB'S standards.

Gerber Files Apertures Description:

All Gerber files stored in the attached CD-ROM were generated from Protel Altium Designer Altium Designer 6. Each file name extension means the following:

1. .gbl Bottom copper, bottom side
2. .gto Top silk screen
3. .gbo Bottom silk screen
4. .gbs Bottom Solder Mask
5. .gko Keep Out,
6. .gm1 Mechanical
7. .gd1 Drill Drawing
8. .gg1 Drill locations
9. .txt CNC data
10. .apr Apertures data

Additional files for assembly that may not be related with Gerber files:

11. .pcb PCB file
12. .bom Bill of materials
13. .cpl Components locations
14. .sch Schematic
15. .csv Pick and Place Components
16. .net Net List
17. .bak Back up files
18. .lib PCB libraries

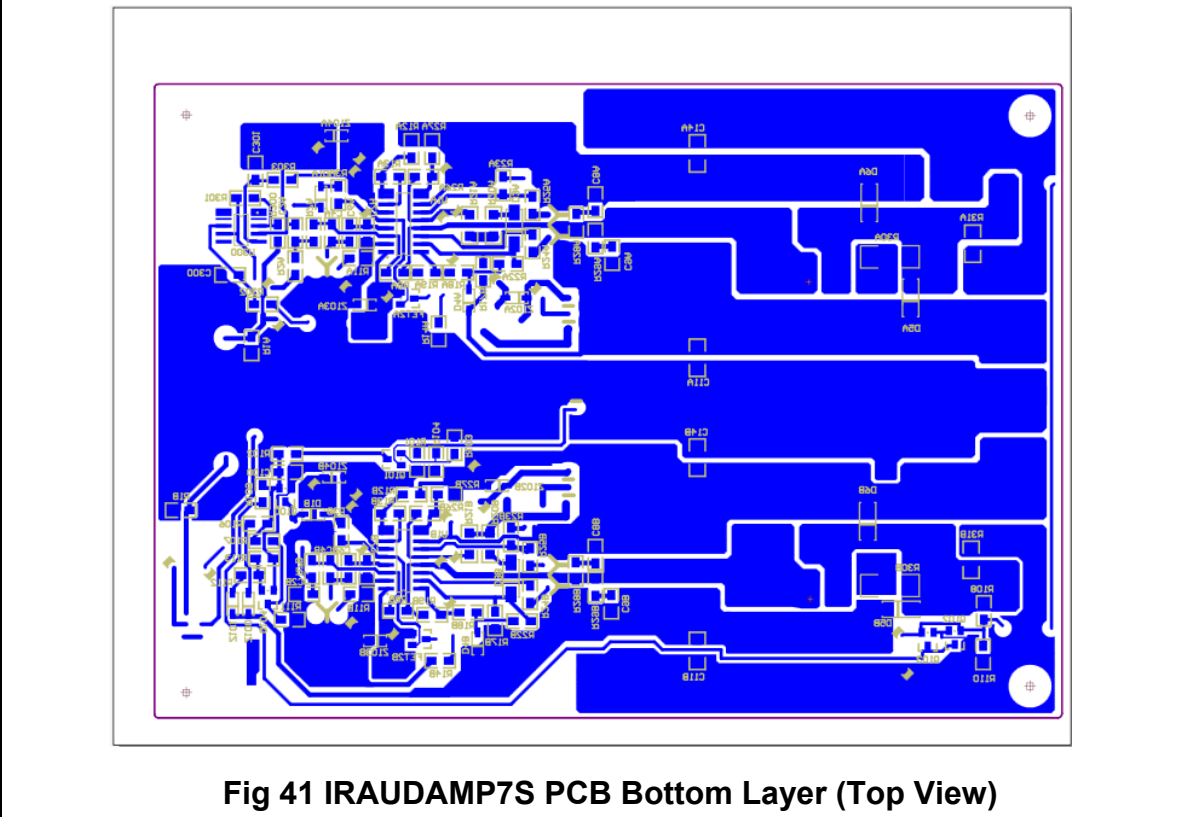
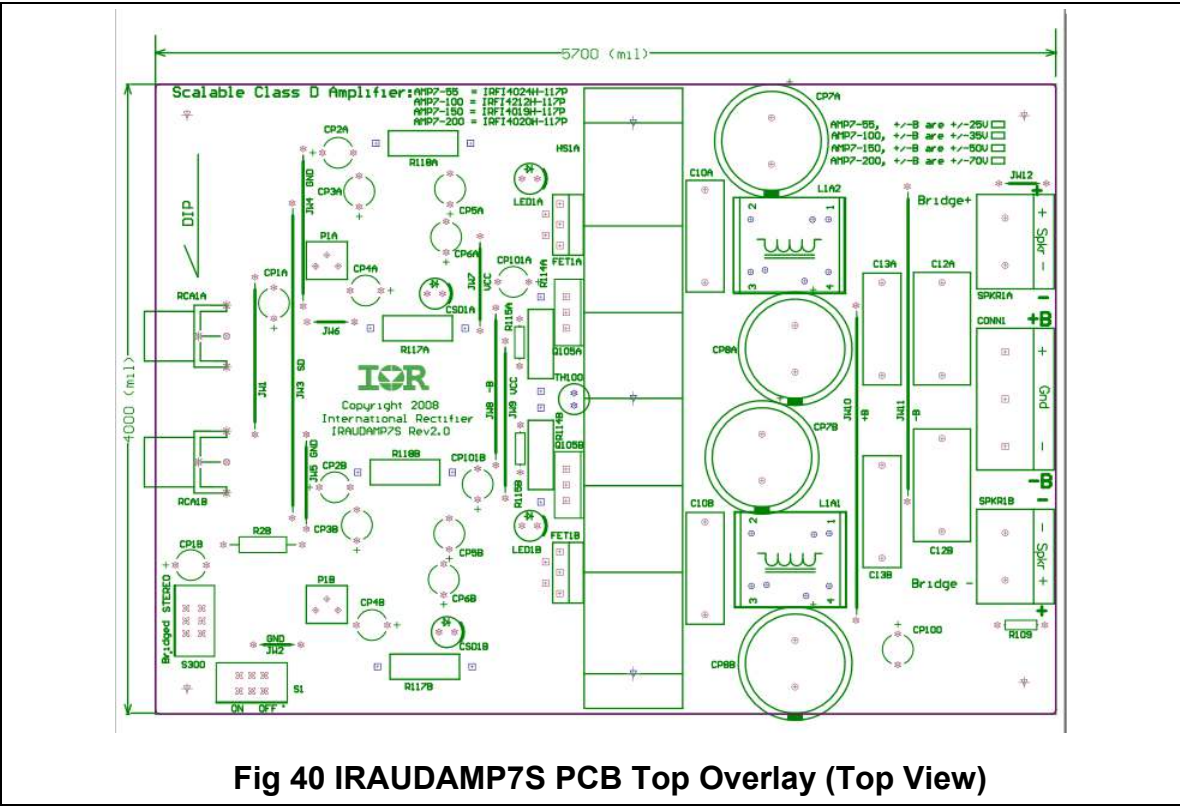

Revision changes descriptions

Revision	Changes description	Date
Rev 1.1	Released	Sep, 03 2008
Rev 1.2	ROHS Compliant(BOM updated)	May, 29 2009
Rev 1.3	BOM updated :Ice Components as a second vender of the inductor	October 28, 2009