

**COMPOSITE SQUARE FLANGE JACK RECEPTACLE**

**R187.413.000**

**PANEL SEAL – FRONT MOUNTING M3 SCREW**

Series : 7/16  
**COMPOSITE**

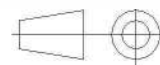
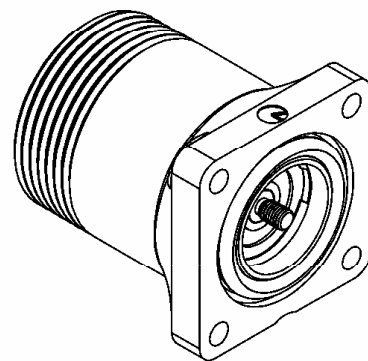
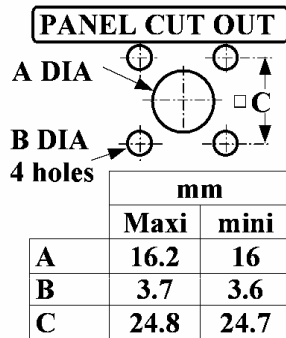
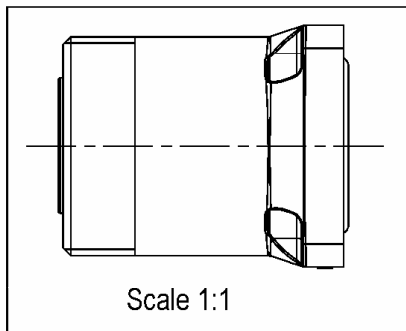
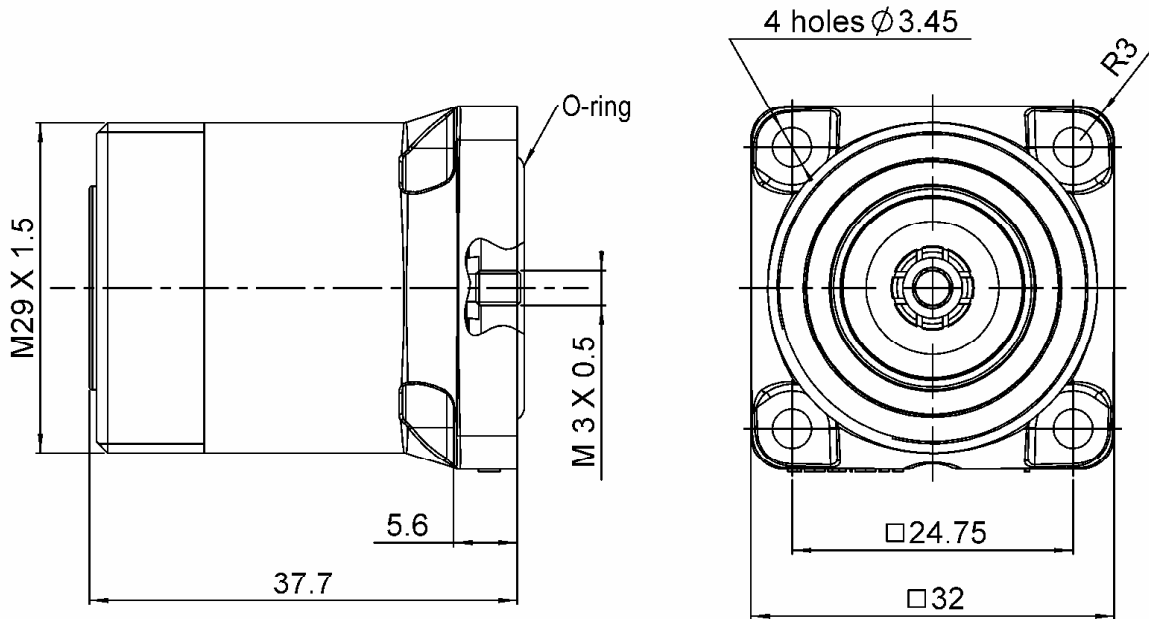

All dimensions are in mm.

COMPONENTS	MATERIALS	PLATING (µm)
<b>BODY</b>	<b>COMPOSITE MATERIAL - BLACK</b>	-
<b>CENTER CONTACT</b>	<b>BRONZE</b>	<b>SILVER 5 OVER COPPER 0.5</b>
<b>OUTER CONTACT</b>	<b>BRASS</b>	<b>BBR 0.5 OVER SILVER 8</b>
<b>INSULATOR</b>	<b>PTFE</b>	-
<b>GASKET</b>	<b>SILICONE RUBBER</b>	-
<b>OTHERS PARTS</b>	-	-
-	-	-
-	-	-

Issue : 0935 C

In the effort to improve our products, we reserve the right to make changes judged to be necessary.



**COMPOSITE SQUARE FLANGE JACK RECEPTACLE**

**R187.413.000**

**PANEL SEAL – FRONT MOUNTING M3 SCREW**

Series : 7/16  
**COMPOSITE**

**PACKAGING**

**SPECIFICATION**

Standard	Unit	Other
<b>40</b>	<b>'W' option</b>	<b>Contact us</b>

**ELECTRICAL CHARACTERISTICS**

**ENVIRONMENTAL**

Impedance **50** Ω  
 Frequency **0-7.5** GHz  
 VSWR **\*1.06 + 0.0000** x F(GHz) Maxi  
 Insertion loss **0.05** √F(GHz) dB Maxi  
 RF leakage - ( **NA** - F(GHz)) dB Maxi  
 Voltage rating **1400** Veff Maxi  
 Dielectric withstanding voltage **2700** Veff mini  
 Insulation resistance **10000** MΩ mini

Operating temperature **-40/+85** ° C  
 Hermetic seal **Atm.cm3/s**  
 Panel leakage **IP67**

**OTHER CHARACTERISTICS**

Assembly instruction

Others :

\*VSWR : 1.06 between DC to 3 GHz  
 \*VSWR : 1.1 between 3 to 7 GHz  
 PIM3:-125dBm under 2 carriers of +43dBm

**MECHANICAL CHARACTERISTICS**

Center contact retention  
 Axial force – Mating end **200** N mini  
 Axial force – Opposite end **NA** N mini  
 Torque **NA** N.cm mini

Recommended torque  
 Mating **N.cm**  
 Panel nut **N.cm**

Mating life **500** Cycles mini  
 Weight **41.0000** g

Issue : 0935 C

In the effort to improve our products, we reserve the right to make changes judged to be necessary.



**COMPOSITE SQUARE FLANGE JACK RECEPTACLE****R187.413.000****PANEL SEAL – FRONT MOUNTING M3 SCREW**Series : 7/16  
**COMPOSITE****Assembly instruction**

Prior to the installation, the outer contact is slightly protruded from the rear flange (0.1~0.45mm). During the installation, the outer contact is pushed inside the composite housing. In its final position, the outer contact is aligned with the rear flange, and in contact with the panel. During mating, the outer contact is pressed against the panel, reducing significantly the IM3 generation.

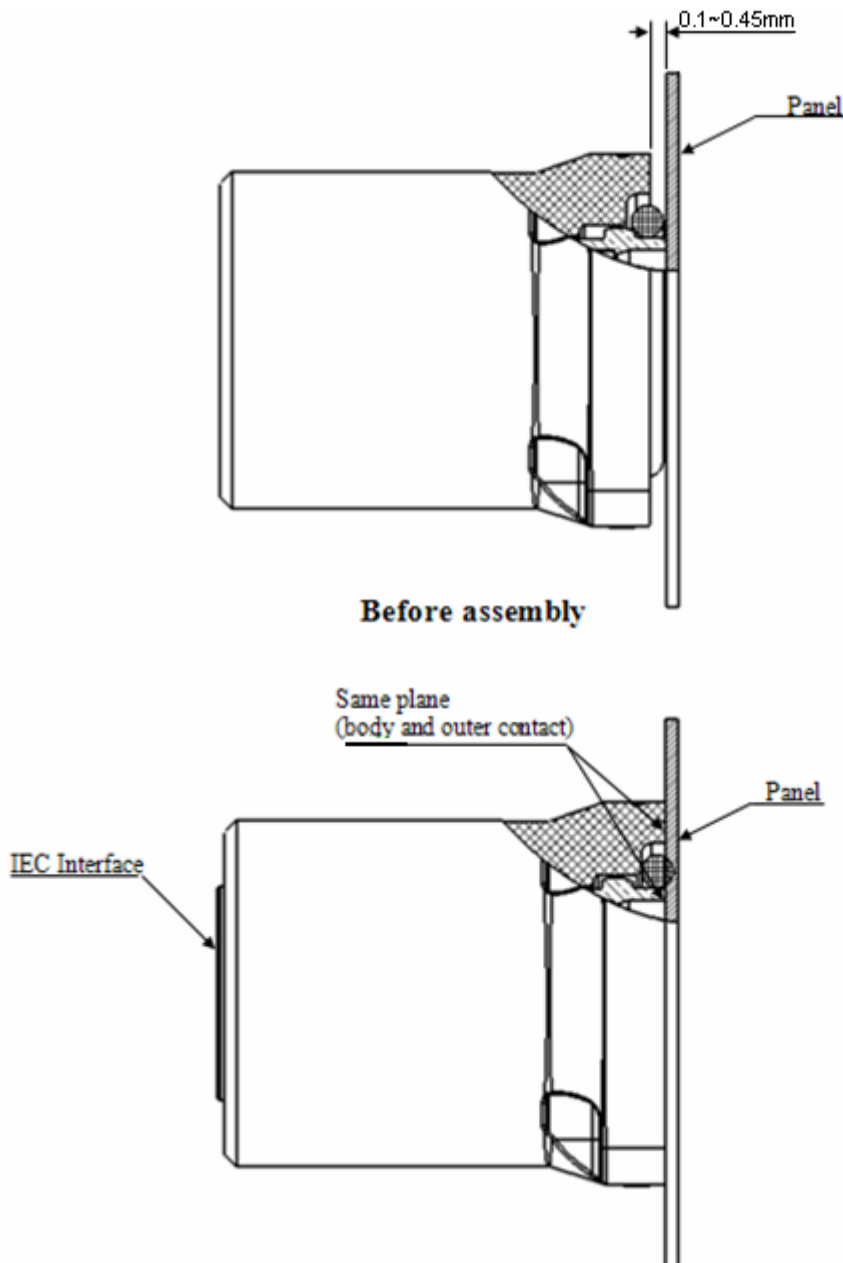
**Issue : 0935 C**

In the effort to improve our products, we reserve the right to make changes judged to be necessary.

**RADIALL** 