

Cascadable Amplifier 100 to 2000 MHz

Rev. V3

Features

- LOW NOISE: <3.5 dB (TYP.)
- LOW VSWR: 1.5:1 (TYP.)

Description

The A31-1 RF amplifier is a discrete hybrid design, which uses thin film manufacturing processes for accurate performance and high reliability.

This single stage bipolar transistor feedback amplifier design displays impressive performance over a broadband frequency range. Both TO-8 and Surface Mount packages are Hermetically sealed, and MIL-STD-883 environmental screening is available.

Product Image

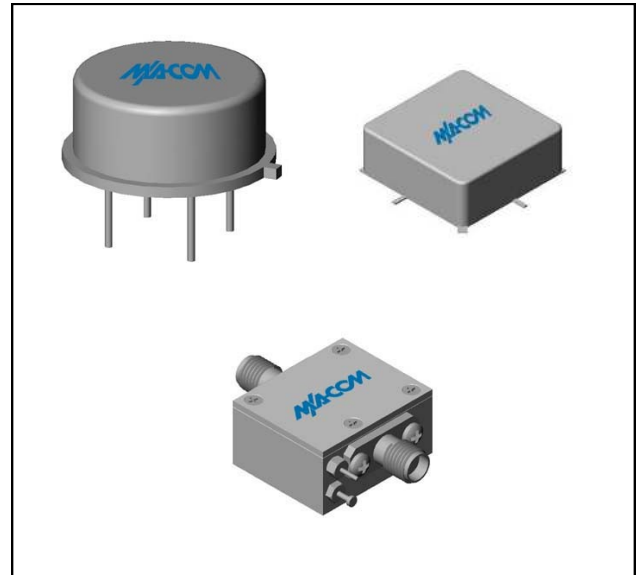

Ordering Information

Part Number	Package
A31-1	TO-8
SMA31-1	Surface Mount
CA31-1 **	SMA Connectorized

** The connectorized version is not RoHs compliant.

Electrical Specifications: $Z_0 = 50\Omega$, $V_{CC} = +15 V_{DC}$

Parameter	Units	Typical	Guaranteed	
		25°C	0° to 50°C	-54° to +85°C*
Frequency	MHz	1-2050	10-2000	10-2000
Small Signal Gain (min)	dB	11.5	11.0	10.5
Gain Flatness (max)	dB	±0.4	±0.7	±1.0
Reverse Isolation	dB	17		
Noise Figure (max)	dB	3.5	4.0	4.5
Power Output @ 1 dB comp. (min)	dBm	-2.0	-4.0	-4.5
IP3	dBm	+9		
IP2	dBm	+10		
Second Order Harmonic IP	dBm	+15		
VSWR Input / Output (max)		1.5:1 / 1.3:1	2.0:1 / 2.0:1	2.0:1 / 2.0:1
DC Current @ 15 Volts (max)	mA	9	11	12

Absolute Maximum Ratings

Parameter	Absolute Maximum
Storage Temperature	-62°C to +125°C
Case Temperature	+125°C
DC Voltage	+18 V
Continuous Input Power	13 dBm
Short Term Input power (1 minute max.)	50 mW
Peak Power (3 µsec max.)	0.5 W
"S" Series Burn-In Temperature (case)	+125°C

Thermal Data: $V_{CC} = +15 V_{DC}$

Parameter	Rating
Thermal Resistance θ_{jc}	185°C/W
Transistor Power Dissipation P_d	0.050 W
Junction Temperature Rise Above Case T_{jc}	+9°C

1 * Over temperature performance limits for part number CA31-1, guaranteed from 0°C to +50°C only.

A31-1 / SMA31-1



Cascadable Amplifier
100 to 2000 MHz

Rev. V3

Typical Performance Curves at +25°C

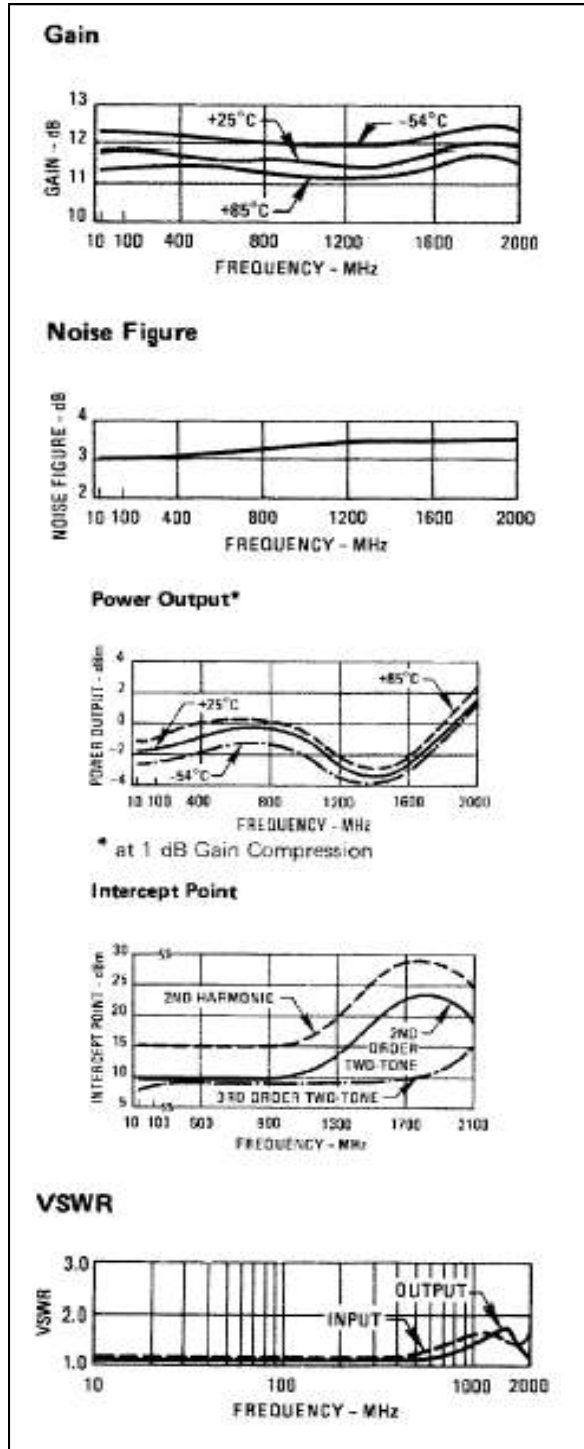

Outline Drawing: TO-8 *

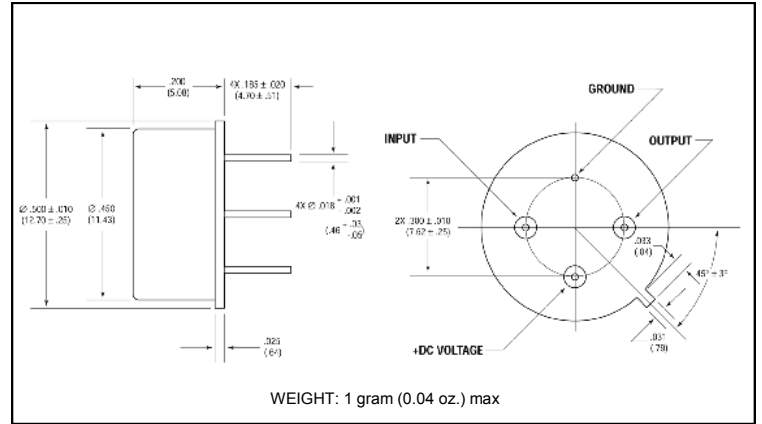

Outline Drawing: Surface Mount *

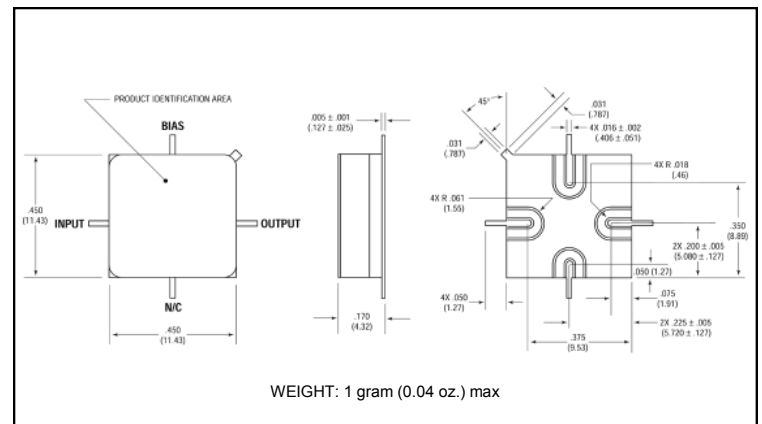

Outline Drawing: SMA Connectorized *

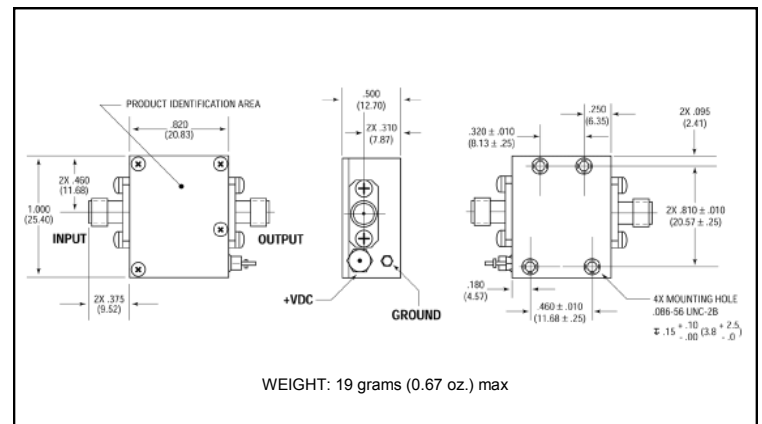

M/A-COM Technology Solutions Inc. All rights reserved.

Information in this document is provided in connection with M/A-COM Technology Solutions Inc ("MACOM") products. These materials are provided by MACOM as a service to its customers and may be used for informational purposes only. Except as provided in MACOM's Terms and Conditions of Sale for such products or in any separate agreement related to this document, MACOM assumes no liability whatsoever. MACOM assumes no responsibility for errors or omissions in these materials. MACOM may make changes to specifications and product descriptions at any time, without notice. MACOM makes no commitment to update the information and shall have no responsibility whatsoever for conflicts or incompatibilities arising from future changes to its specifications and product descriptions. No license, express or implied, by estoppels or otherwise, to any intellectual property rights is granted by this document.

THESE MATERIALS ARE PROVIDED "AS IS" WITHOUT WARRANTY OF ANY KIND, EITHER EXPRESS OR IMPLIED, RELATING TO SALE AND/OR USE OF MACOM PRODUCTS INCLUDING LIABILITY OR WARRANTIES RELATING TO FITNESS FOR A PARTICULAR PURPOSE, CONSEQUENTIAL OR INCIDENTAL DAMAGES, MERCHANTABILITY, OR INFRINGEMENT OF ANY PATENT, COPYRIGHT OR OTHER INTELLECTUAL PROPERTY RIGHT. MACOM FURTHER DOES NOT WARRANT THE ACCURACY OR COMPLETENESS OF THE INFORMATION, TEXT, GRAPHICS OR OTHER ITEMS CONTAINED WITHIN THESE MATERIALS. MACOM SHALL NOT BE LIABLE FOR ANY SPECIAL, INDIRECT, INCIDENTAL, OR CONSEQUENTIAL DAMAGES, INCLUDING WITHOUT LIMITATION, LOST REVENUES OR LOST PROFITS, WHICH MAY RESULT FROM THE USE OF THESE MATERIALS.

MACOM products are not intended for use in medical, lifesaving or life sustaining applications. MACOM customers using or selling MACOM products for use in such applications do so at their own risk and agree to fully indemnify MACOM for any damages resulting from such improper use or sale.

M/A-COM Technology Solutions Inc. (MACOM) and its affiliates reserve the right to make changes to the product(s) or information contained herein without notice.
Visit www.macom.com for additional data sheets and product information.