

MC33063A-Q1 1.5-A Peak Boost, Buck, Inverting Switching Regulator

1 Features

- AEC-Q100 Qualified With the Following Results:
 - Device HBM ESD Classification Level 2
 - Device CDM ESD Classification Level C4B
- Wide Input Voltage Range: 3 V to 40 V
- High Output Switch Current: Up to 1.5 A
- Adjustable Output Voltage
- Oscillator Frequency: Up to 100 kHz
- Precision Internal Reference: 2%
- Short-Circuit Current Limiting
- Low Standby Current

2 Applications

Automotive: Buck, Boost, and Inverting Topologies

3 Description

The MC33063A-Q1 device is an easy-to-use IC containing all the primary circuitry needed for building simple DC-DC converters. The device primarily consists of an internal temperature-compensated reference, a comparator, an oscillator, a PWM controller with active current limiting, a driver, and a high-current output switch. Thus, the device requires minimal external components to build converters in the boost, buck, and inverting topologies.

The MC33063A-Q1 device is characterized for operation from -40°C to 125°C .

Device Information⁽¹⁾

PART NUMBER	PACKAGE	BODY SIZE (NOM)
MC33063A-Q1	SOIC (8)	4.90 mm × 3.91 mm

(1) For all available packages, see the orderable addendum at the end of the datasheet.

Simplified Schematic

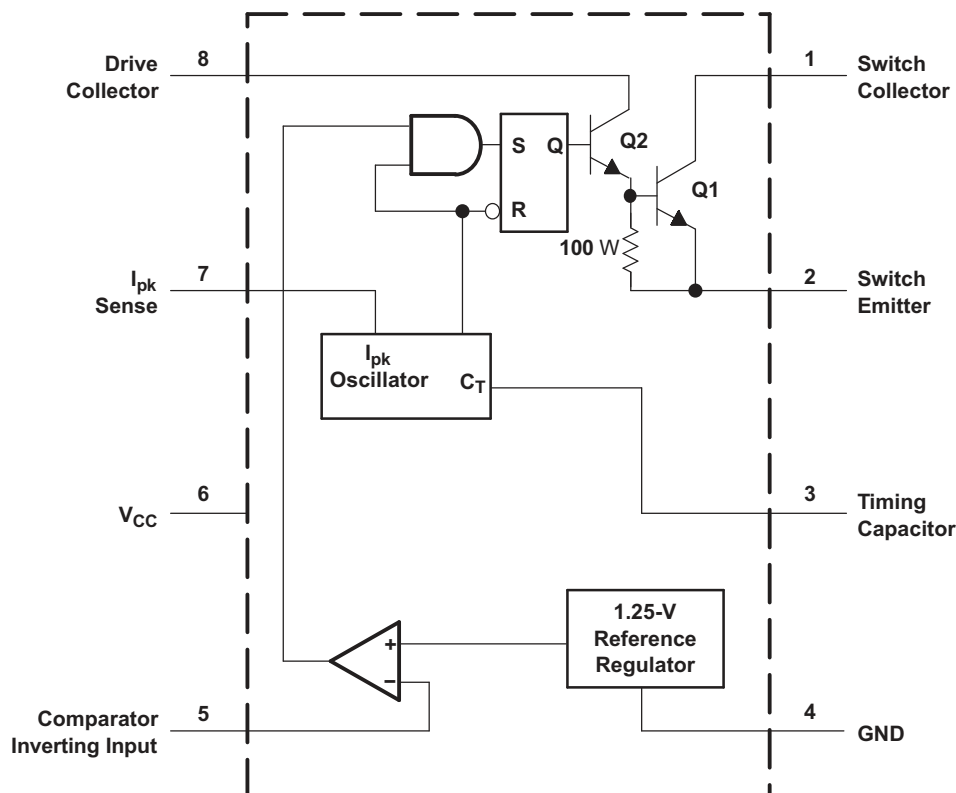

Table of Contents

1 Features	1	7.1 Overview	7
2 Applications	1	7.2 Functional Block Diagram	7
3 Description	1	7.3 Feature Description	7
4 Revision History	2	7.4 Device Functional Modes	9
5 Pin Configuration and Functions	3	8 Application and Implementation	10
6 Specifications	4	8.1 Application Information	10
6.1 Absolute Maximum Ratings	4	8.2 Typical Applications	10
6.2 ESD Ratings	4	9 Power Supply Recommendations	18
6.3 Recommended Operating Conditions	4	10 Layout	19
6.4 Thermal Information	4	10.1 Layout Guidelines	19
6.5 Oscillator Characteristics	5	10.2 Layout Example	19
6.6 Output Switch Characteristics	5	11 Device and Documentation Support	22
6.7 Comparator Characteristics	5	11.1 Trademarks	22
6.8 Total Device Characteristics	5	11.2 Electrostatic Discharge Caution	22
6.9 Typical Characteristics	6	11.3 Glossary	22
7 Detailed Description	7	12 Mechanical, Packaging, and Orderable Information	22

4 Revision History

Changes from Revision B (September 2008) to Revision C

Page

- Added the *ESD Ratings* table, *Feature Description* section, *Device Functional Modes* section, *Application and Implementation* section, *Power Supply Recommendations* section, *Layout* section, *Device and Documentation Support* section, and *Mechanical, Packaging, and Orderable Information* section **1**

5 Pin Configuration and Functions

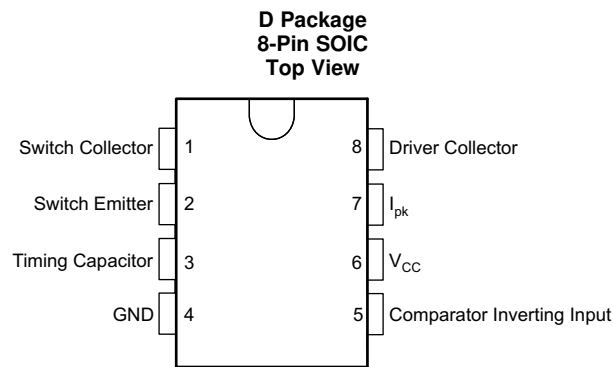

Pin Functions

PIN		I/O	DESCRIPTION
NO.	NAME		
1	Switch Collector	—	Switch Collector
2	Switch Emitter	—	Switch Emitter
3	Timing Capacitor	—	Timing Capacitor
4	GND	—	Ground
5	Comparator Inverting Input	I	Comparator Inverting Input
6	V _{CC}	I	Supply
7	I _{PK}	I	Peak Current
8	Driver Collector	—	Driver Collector

6 Specifications

6.1 Absolute Maximum Ratings⁽¹⁾

over operating free-air temperature range (unless otherwise noted)

	MIN	MAX	UNIT
Supply voltage, V_{CC}		40	V
Comparator Inverting Input voltage range, V_{IR}	-0.3	40	V
Switch Collector voltage, $V_{C(switch)}$		40	V
Switch Emitter voltage, $V_{E(switch)}$ $V_{PIN1} = 40$ V		40	V
Switch Collector to Switch Emitter voltage, $V_{CE(switch)}$		40	V
Driver Collector voltage, $V_{C(driver)}$		40	V
Driver Collector current, $I_{C(driver)}$		100	mA
Switch current, I_{SW}		1.5	A
Operating virtual junction temperature, T_J		150	°C
Storage temperature, T_{stg}	-65	150	°C

- (1) Stresses beyond those listed under *absolute maximum ratings* may cause permanent damage to the device. These are stress ratings only, and functional operation of the device at these or any other conditions beyond those indicated under "recommended operating conditions" is not implied. Exposure to absolute-maximum-rated conditions for extended periods may affect device reliability.

6.2 ESD Ratings

		VALUE	UNIT	
$V_{(ESD)}$ Electrostatic discharge	Human body model (HBM), per AEC Q100-002 ⁽¹⁾	±2000	V	
	Charged device model (CDM), per AEC Q100-011	Corner pins (1, 4, 5, and 8)		±750
		Other pins		±500

- (1) AEC Q100-002 indicates HBM stressing is done in accordance with the ANSI/ESDA/JEDEC JS-001 specification.

6.3 Recommended Operating Conditions

	MIN	NOM	MAX	UNIT
V_{CC} Supply voltage	3		40	V
T_A Operating free-air temperature	-40		125	°C

6.4 Thermal Information

THERMAL METRIC ⁽¹⁾		MC33063A-Q1	UNIT
		D	
		8 PINS	
$R_{\theta JA}$	Junction-to-ambient thermal resistance ⁽²⁾⁽³⁾	121.9	°C/W
$R_{\theta JC(top)}$	Junction-to-case (top) thermal resistance	68.1	
$R_{\theta JB}$	Junction-to-board thermal resistance	62.3	
Ψ_{JT}	Junction-to-top characterization parameter	19.9	
Ψ_{JB}	Junction-to-board characterization parameter	61.8	
$R_{\theta JC(bot)}$	Junction-to-case (bottom) thermal resistance	N/A	

- (1) For more information about traditional and new thermal metrics, see the *IC Package Thermal Metrics* application report, [SPRA953](#).
 (2) Maximum power dissipation is a function of $T_J(max)$, $R_{\theta JA}$, and T_A . The maximum allowable power dissipation at any allowable ambient temperature is $P_D = (T_J(max) - T_A) / R_{\theta JA}$. Operating at the absolute maximum T_J of 150°C can affect reliability.
 (3) The package thermal impedance is calculated in accordance with JESD 51-7.

6.5 Oscillator Characteristics

$V_{CC} = 5\text{ V}$, $T_A =$ full operating range (unless otherwise noted) (see block diagram)

PARAMETER		TEST CONDITIONS	T_A	MIN	TYP	MAX	UNIT
f_{osc}	Oscillator frequency	$V_{PIN5} = 0\text{ V}$, $C_T = 1\text{ nF}$	25°C	24	33	42	kHz
I_{chg}	Charge current	$V_{CC} = 5\text{ V to } 40\text{ V}$	25°C	24	35	42	μA
I_{dischg}	Discharge current	$V_{CC} = 5\text{ V to } 40\text{ V}$	25°C	140	220	260	μA
I_{dischg}/I_{chg}	Discharge-to-charge current ratio	$V_{PIN7} = V_{CC}$	25°C	5.2	6.5	7.5	
V_{lpk}	Current-limit sense voltage	$I_{dischg} = I_{chg}$	25°C	250	300	350	mV

6.6 Output Switch Characteristics⁽¹⁾

$V_{CC} = 5\text{ V}$, $T_A =$ full operating range (unless otherwise noted). See the [Functional Block Diagram](#).

PARAMETER		TEST CONDITIONS	T_A	MIN	TYP	MAX	UNIT
$V_{CE(sat)}$	Saturation voltage – Darlington connection	$I_{SW} = 1\text{ A}$, pins 1 and 8 connected	Full range		1	1.3	V
$V_{CE(sat)}$	Saturation voltage – non-Darlington connection ⁽²⁾	$I_{SW} = 1\text{ A}$, $R_{PIN8} = 82\ \Omega$ to V_{CC} , Forced $\beta \sim 20$	Full range		0.45	0.7	V
h_{FE}	DC current gain	$I_{SW} = 1\text{ A}$, $V_{CE} = 5\text{ V}$	25°C	50	75		
$I_{C(off)}$	Collector off-state current	$V_{CE} = 40\text{ V}$	Full range		0.01	100	μA

(1) Low duty-cycle pulse testing is used to maintain junction temperature as close to ambient temperature as possible.

(2) In the non-Darlington configuration, if the output switch is driven into hard saturation at low switch currents ($\leq 300\text{ mA}$) and high driver currents ($\geq 30\text{ mA}$), it may take up to $2\ \mu\text{s}$ for the switch to come out of saturation. This condition effectively shortens the off time at frequencies $\geq 30\text{ kHz}$, becoming magnified as temperature increases. The following output drive condition is recommended in the non-Darlington configuration:

Forced β of output switch = $I_{C,SW} / (I_{C,driver} - 7\text{ mA}) \geq 10$, where $\sim 7\text{ mA}$ is required by the $100\text{-}\Omega$ resistor in the emitter of the driver to forward bias the V_{be} of the switch.

6.7 Comparator Characteristics

$V_{CC} = 5\text{ V}$, $T_A =$ full operating range (unless otherwise noted). See the [Functional Block Diagram](#).

PARAMETER		TEST CONDITIONS	T_A	MIN	TYP	MAX	UNIT
V_{th}	Threshold voltage		25°C	1.225	1.25	1.275	V
			Full range	1.21		1.29	
ΔV_{th}	Threshold-voltage line regulation	$V_{CC} = 5\text{ V to } 40\text{ V}$	Full range		1.4	5	mV
I_{IB}	Input bias current	$V_{IN} = 0\text{ V}$	Full range		-20	-400	nA

6.8 Total Device Characteristics

$V_{CC} = 5\text{ V}$, $T_A =$ full operating range (unless otherwise noted). See the [Functional Block Diagram](#).

PARAMETER		TEST CONDITIONS	T_A	MIN	MAX	UNIT
I_{CC}	Supply current	$V_{CC} = 5\text{ V to } 40\text{ V}$, $C_T = 1\text{ nF}$, $V_{PIN7} = V_{CC}$, $V_{PIN5} > V_{th}$, $V_{PIN2} = \text{GND}$, All other pins open	Full range		4	mA

6.9 Typical Characteristics

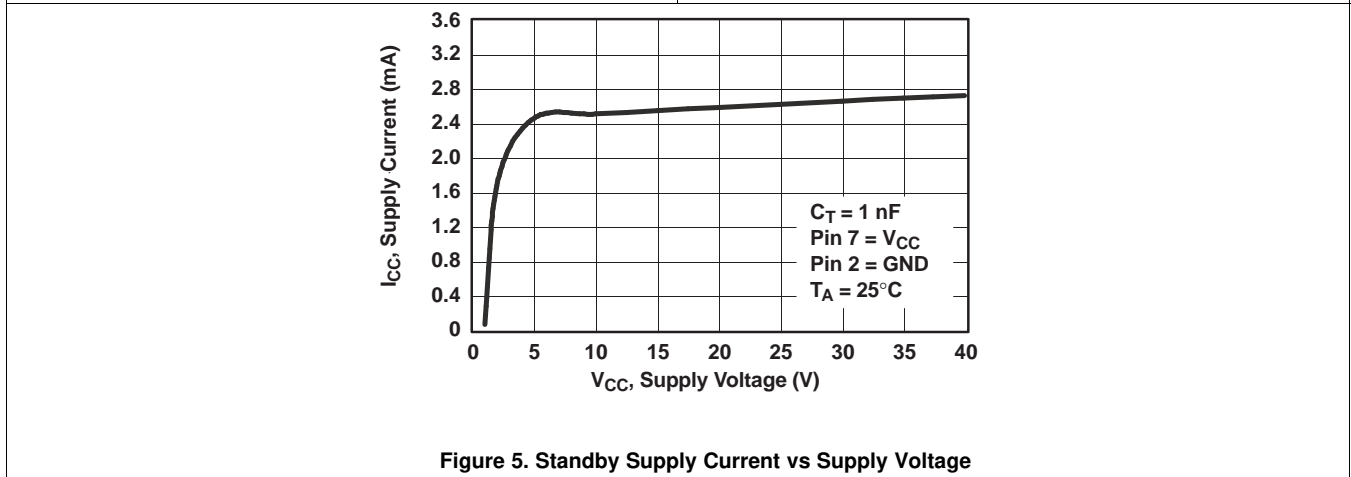
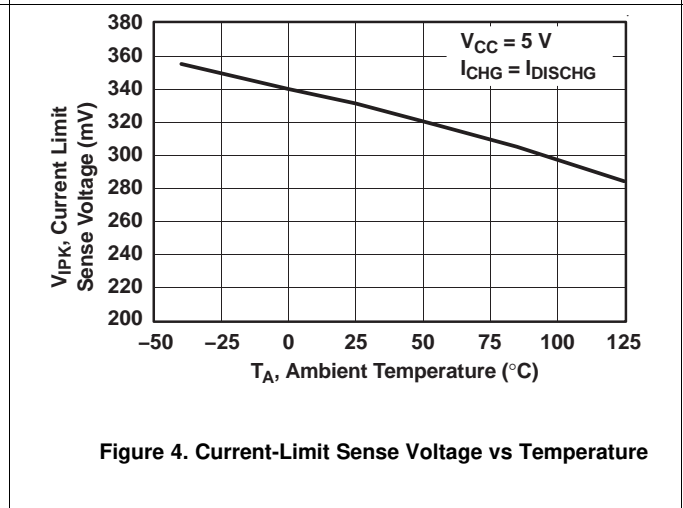
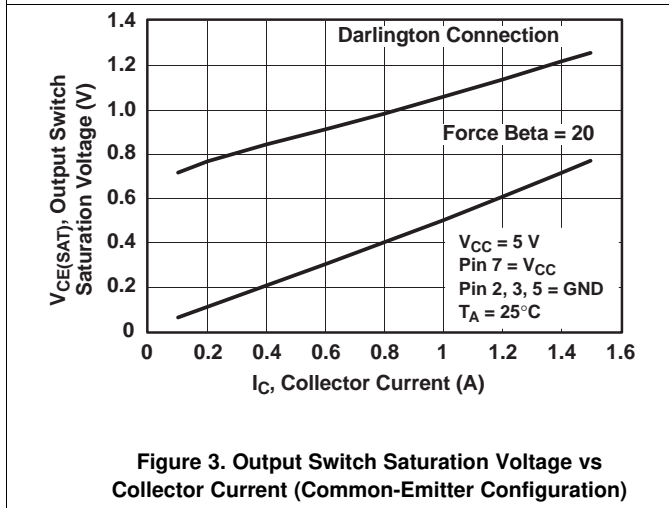
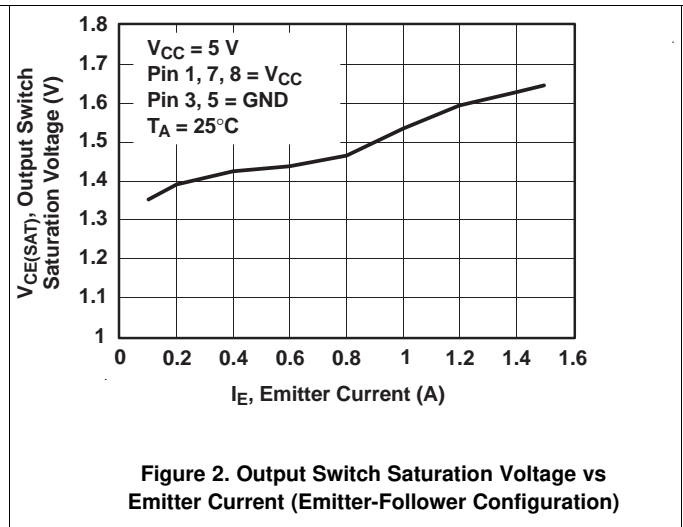
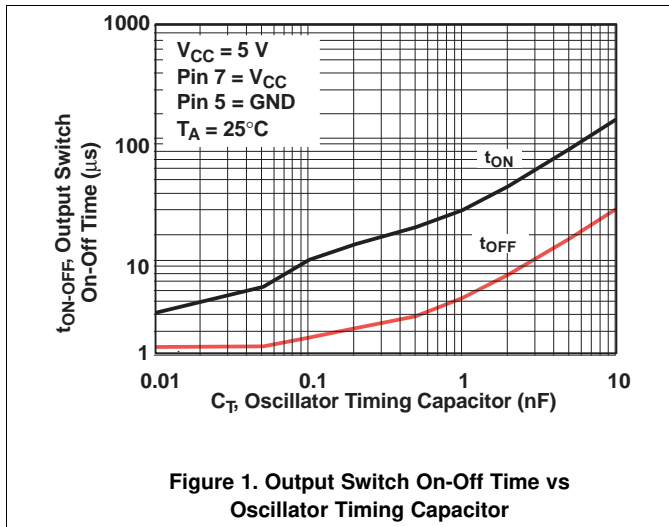

7 Detailed Description

7.1 Overview

The MC33063A-Q1 device primarily consists of an internal temperature-compensated reference, a comparator, an oscillator, a PWM controller with active current limiting, a driver, and a high-current output switch. The MC33063A-Q1 device requires minimal external components to build converters in the boost, buck, and inverting topologies.

7.2 Functional Block Diagram

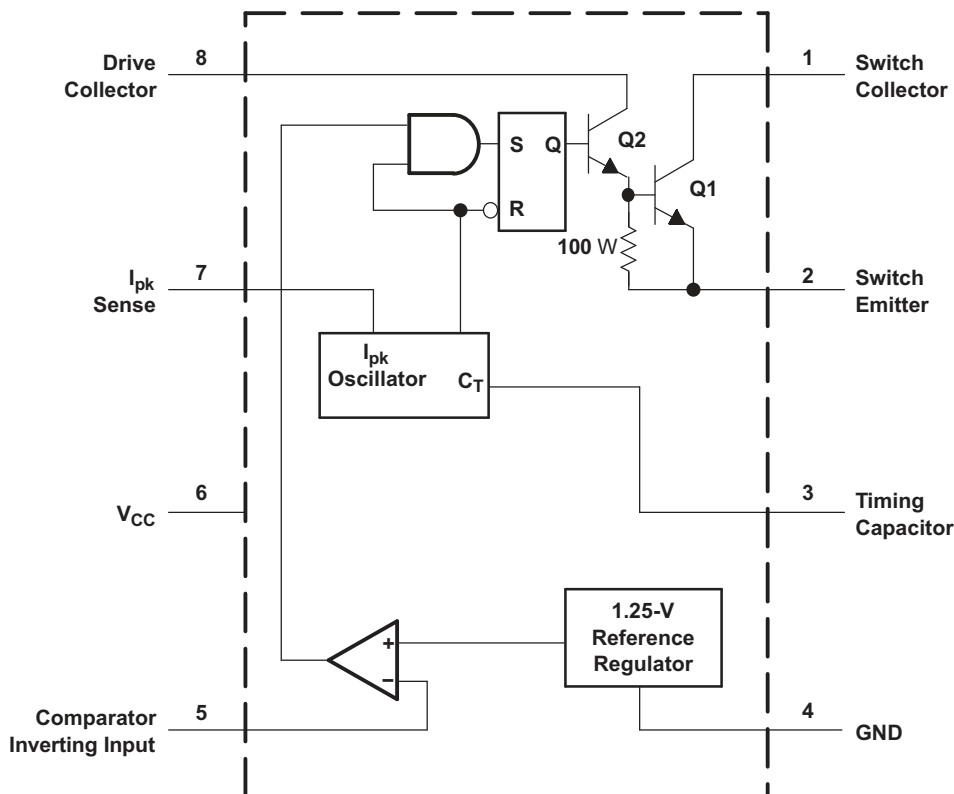

7.3 Feature Description

The device includes the following components:

- Temperature-compensated reference voltage
- Oscillator
- Active peak-current limit
- Output switch
- Output voltage-sense comparator

7.3.1 Reference Voltage

The reference voltage is set at 1.25 V and is used to set the output voltage of the converter.

Feature Description (continued)

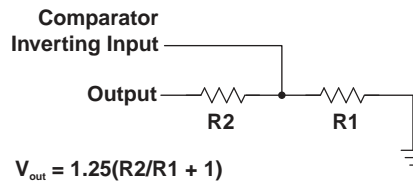

Figure 6. Reference Voltage Circuit

7.3.2 Current Limit

Current limit is accomplished by monitoring the voltage drop across an external sense resistor located in series with VCC and the output switch. The voltage drop developed across the sense resistor is monitored by the current-sense pin, I_{pk}. When the voltage drop across the sense resistor becomes greater than the preset value of 330 mV, the current-limit circuitry provides an additional current path to charge the timing capacitor (CT) rapidly, to reach the upper oscillator threshold and, thus, limiting the amount of energy stored in the inductor. The minimum sense resistor is 0.2 W. Figure 7 shows the timing capacitor charge current versus current-limit sense voltage. To set the peak current, I_{pk} = 330 mV/R_{sense}.

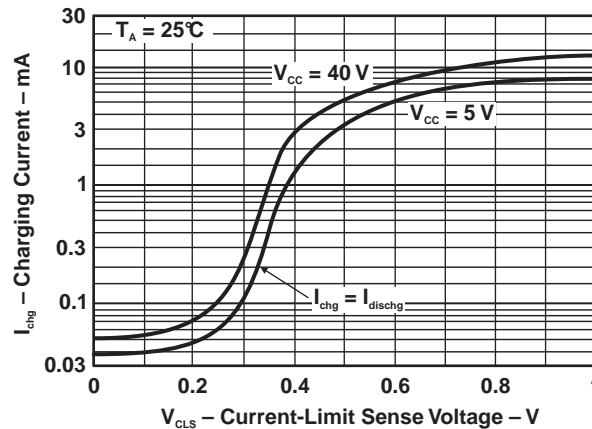

Figure 7. Timing Capacitor Charge Current vs Current-Limit Sense Voltage

7.3.3 Current Limit of Typical Operation Waveforms

The output switch is an NPN Darlington transistor. The collector of the output transistor is tied to pin 1, and the emitter is tied to pin 2. This allows the designer to use the MC33063 device in buck, boost, or inverter configurations. The maximum collector-emitter saturation voltage at 1.5 A (peak) is 1.3 V, and the maximum peak current of the output switch is 1.5 A. For higher peak output current, an external transistor can be used. Figure 8 shows the typical operation waveforms.

Feature Description (continued)

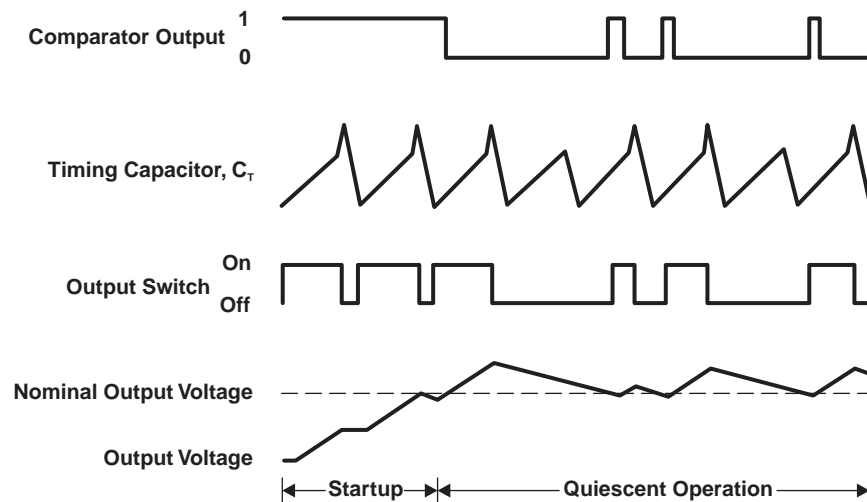

Figure 8. Typical Operation Waveforms

7.4 Device Functional Modes

The oscillator is composed of a current source and a current sink that charge and discharge the external timing capacitor (CT) between an upper and lower preset threshold. The typical charge current is 35 mA, and the typical discharge current is 200 mA, yielding approximately a 6:1 ratio. Thus, the ramp-up period is six times longer than that of the ramp-down period (see Figure 9). The upper threshold is 1.25 V, which is same as the internal reference voltage, and the lower threshold is 0.75 V. The oscillator runs constantly, at a pace controlled by the value of CT.

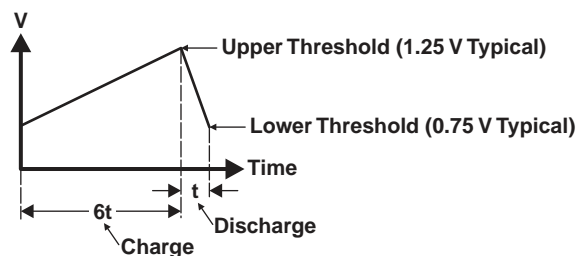

Figure 9. Oscillator Voltage Thresholds

8 Application and Implementation

NOTE

Information in the following applications sections is not part of the TI component specification, and TI does not warrant its accuracy or completeness. TI's customers are responsible for determining suitability of components for their purposes. Customers should validate and test their design implementation to confirm system functionality.

8.1 Application Information

The MC33063A-Q1 device requires minimal external components to build converters in the boost, buck, and inverting topologies.

8.2 Typical Applications

8.2.1 Step-Up Converter

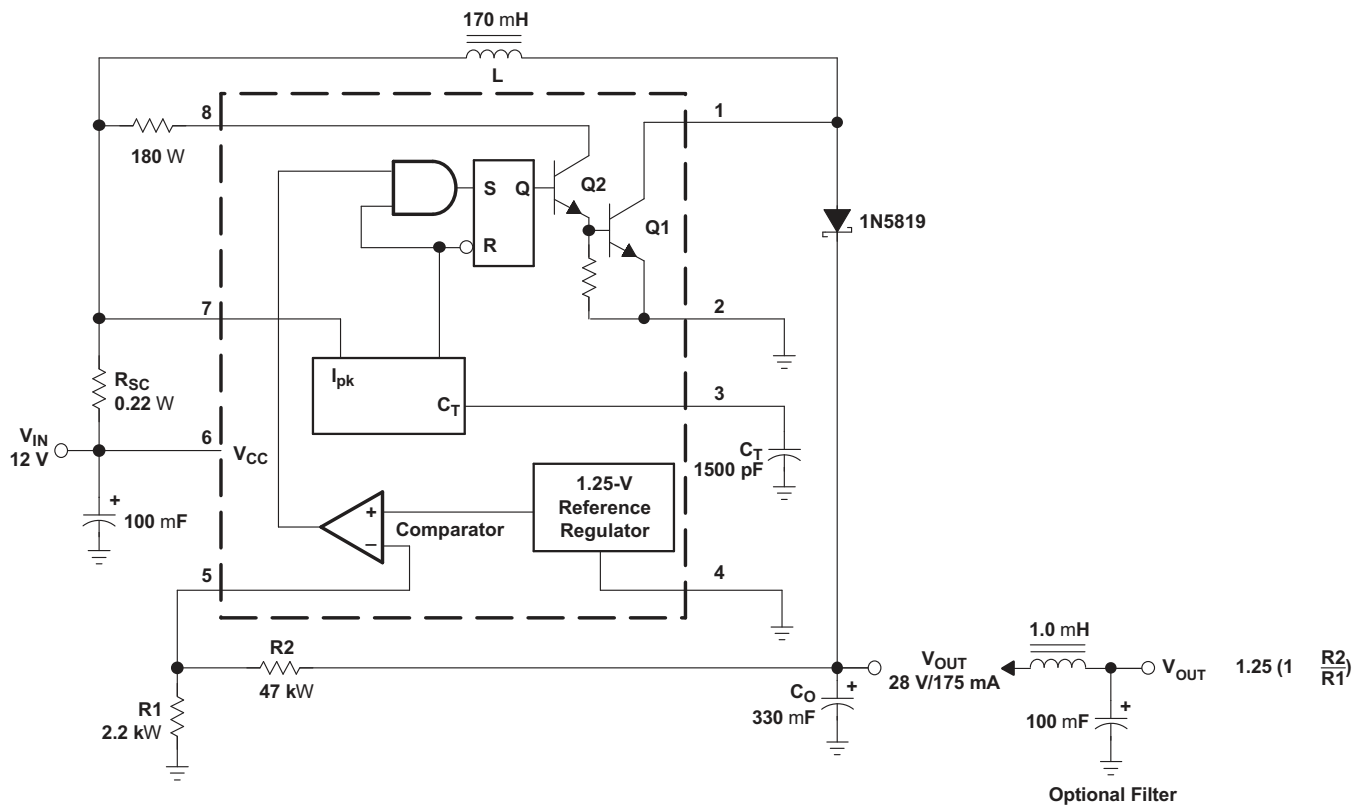

Figure 10. Step-Up Converter

Typical Applications (continued)

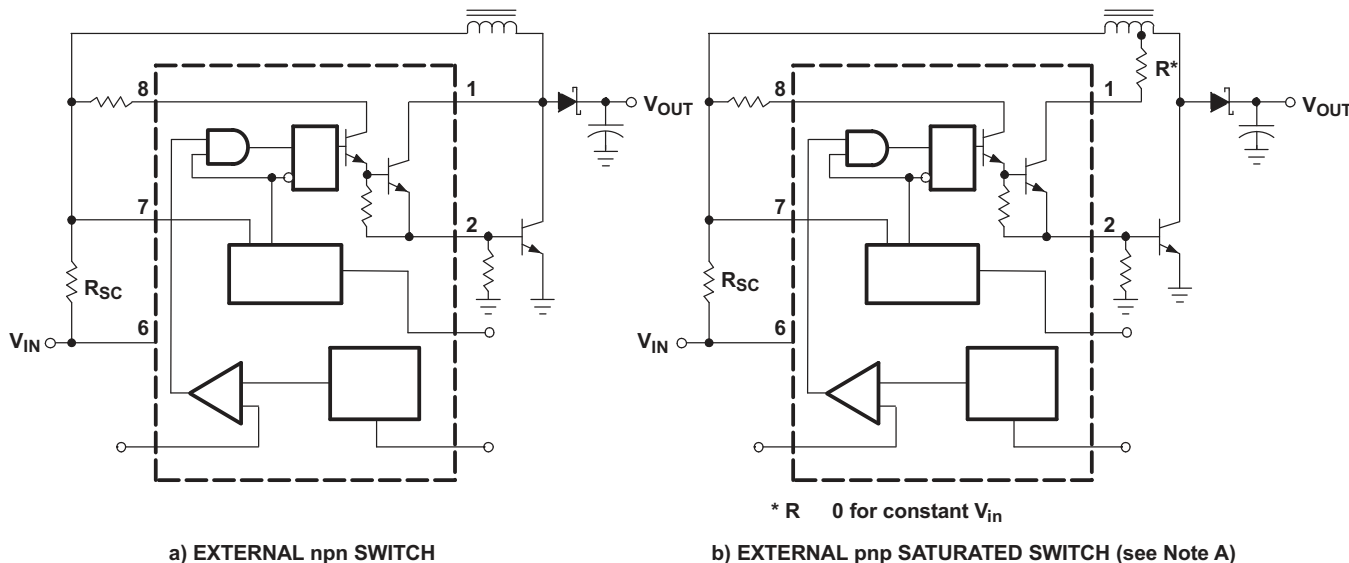

Figure 11. External Switches

8.2.1.1 Design Requirements

Table 1. Step-Up Converter

TEST	CONDITIONS	RESULTS
Line regulation	$V_{IN} = 8\text{ V to }16\text{ V}, I_O = 175\text{ mA}$	$30\text{ mV} \pm 0.05\%$
Load regulation	$V_{IN} = 12\text{ V}, I_O = 75\text{ mA to }175\text{ mA}$	$10\text{ mV} \pm 0.017\%$
Output ripple	$V_{IN} = 12\text{ V}, I_O = 175\text{ mA}$	400 mV_{PP}
Efficiency	$V_{IN} = 12\text{ V}, I_O = 175\text{ mA}$	87.7%
Output ripple with optional filter	$V_{IN} = 12\text{ V}, I_O = 175\text{ mA}$	40 mV_{PP}

8.2.1.2 Detailed Design Procedure

CALCULATION	STEP UP	STEP DOWN	VOLTAGE INVERTING
t_{on}/t_{off}	$\frac{V_{out} + V_F - V_{in(min)}}{V_{in(min)} - V_{sat}}$	$\frac{V_{out} + V_F}{V_{in(min)} - V_{sat} - V_{out}}$	$\frac{V_{out} + V_F}{V_{in} - V_{sat}}$
$(t_{on} + t_{off})$	$\frac{1}{f}$	$\frac{1}{f}$	$\frac{1}{f}$
t_{off}	$\frac{t_{on} + t_{off}}{\frac{t_{on}}{t_{off}} + 1}$	$\frac{t_{on} + t_{off}}{\frac{t_{on}}{t_{off}} + 1}$	$\frac{t_{on} + t_{off}}{\frac{t_{on}}{t_{off}} + 1}$
t_{on}	$(t_{on} + t_{off}) - t_{off}$	$(t_{on} + t_{off}) - t_{off}$	$(t_{on} + t_{off}) - t_{off}$
C_T	$4 \times 10^{-5} t_{on}$	$4 \times 10^{-5} t_{on}$	$4 \times 10^{-5} t_{on}$
$I_{pk(switch)}$	$2I_{out(max)} \left(\frac{t_{on}}{t_{off}} + 1 \right)$	$2I_{out(max)}$	$2I_{out(max)} \left(\frac{t_{on}}{t_{off}} + 1 \right)$
R_{sc}	$\frac{0.3}{I_{pk(switch)}}$	$\frac{0.3}{I_{pk(switch)}}$	$\frac{0.3}{I_{pk(switch)}}$
$L_{(min)}$	$\left(\frac{V_{in(min)} - V_{sat}}{I_{pk(switch)}} \right) t_{on(max)}$	$\left(\frac{V_{in(min)} - V_{sat} - V_{out}}{I_{pk(switch)}} \right) t_{on(max)}$	$\left(\frac{V_{in(min)} - V_{sat}}{I_{pk(switch)}} \right) t_{on(max)}$

CALCULATION	STEP UP	STEP DOWN	VOLTAGE INVERTING
C_O	$9 \frac{I_{out} t_{on}}{V_{ripple(pp)}}$	$\frac{I_{pk(switch)}(t_{on} + t_{off})}{8V_{ripple(pp)}}$	$9 \frac{I_{out} t_{on}}{V_{ripple(pp)}}$

8.2.1.3 Application Curve

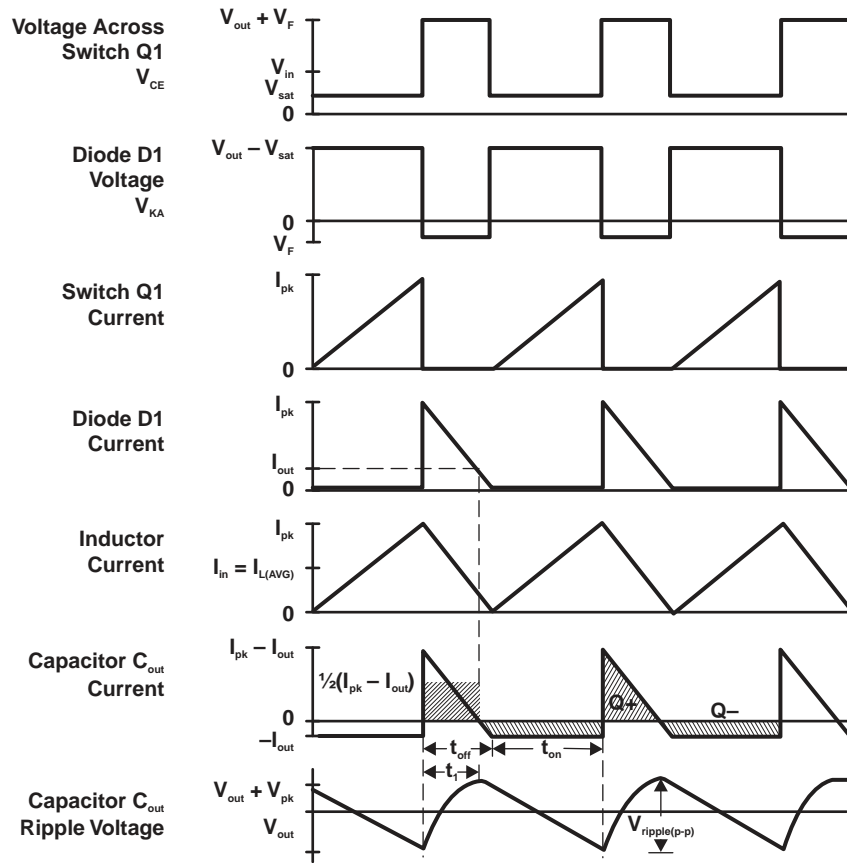

Figure 12. Boost Switching Regulator Waveforms

8.2.2 Step-Down Converter

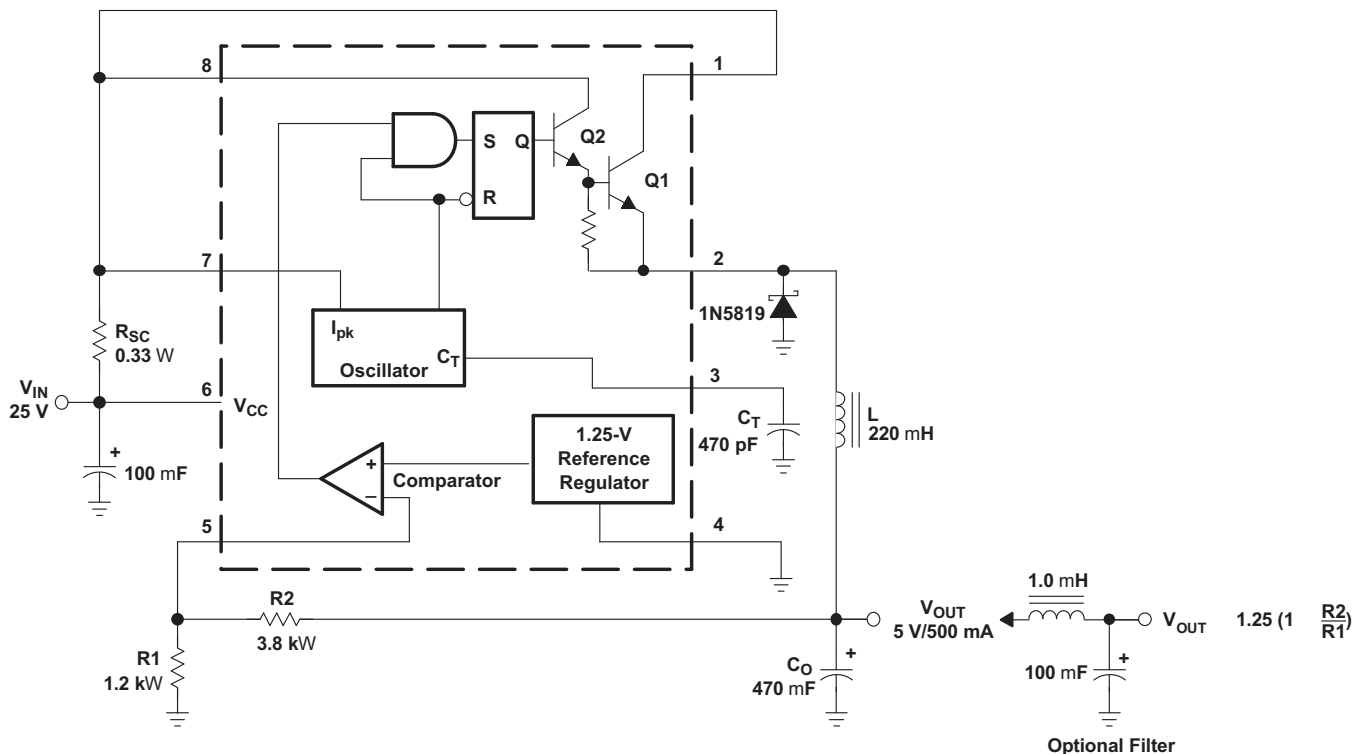

Figure 13. Step-Down Converter

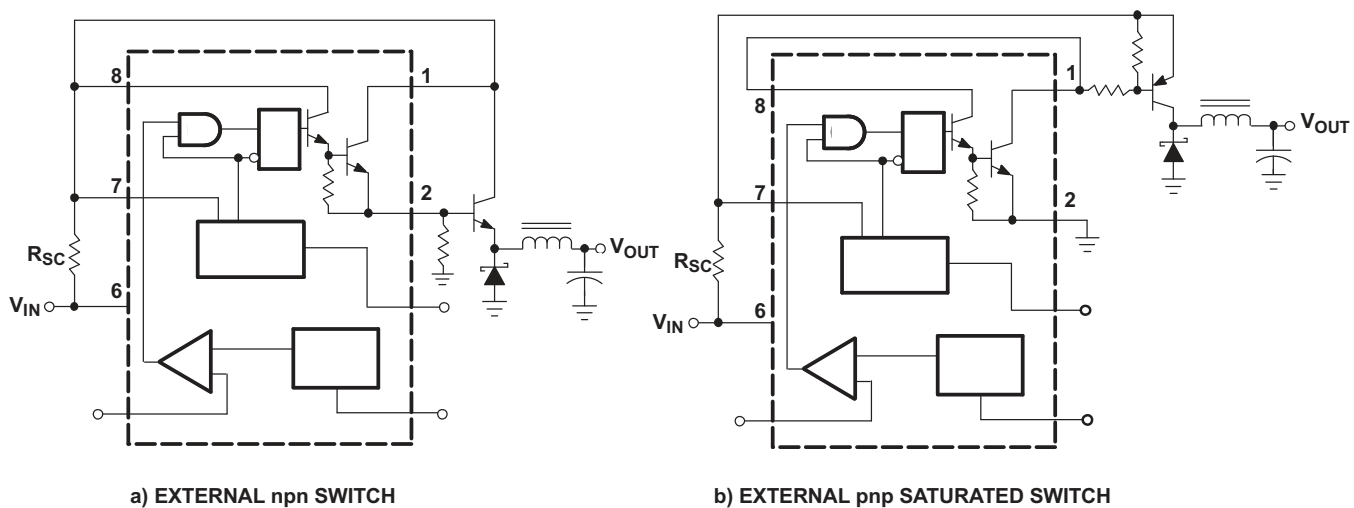

Figure 14. External Current-Boost Connections for I_C Peak Greater Than 1.5 A

8.2.2.1 Design Requirements

Table 2. Step-Down Converter

TEST	CONDITIONS	RESULTS
Line regulation	$V_{IN} = 15\text{ V to }25\text{ V}, I_O = 500\text{ mA}$	$12\text{ mV} \pm 0.12\%$
Load regulation	$V_{IN} = 25\text{ V}, I_O = 50\text{ mA to }500\text{ mA}$	$3\text{ mV} \pm 0.03\%$
Output ripple	$V_{IN} = 25\text{ V}, I_O = 500\text{ mA}$	120 mV_{PP}
Short-circuit current	$V_{IN} = 25\text{ V}, R_L = 0.1\ \Omega$	1.1 A
Efficiency	$V_{IN} = 25\text{ V}, I_O = 500\text{ mA}$	83.7%
Output ripple with optional filter	$V_{IN} = 25\text{ V}, I_O = 500\text{ mA}$	40 mV_{PP}

8.2.2.2 Detailed Design Procedure

See [Detailed Design Procedure](#).

8.2.2.3 Application Curves

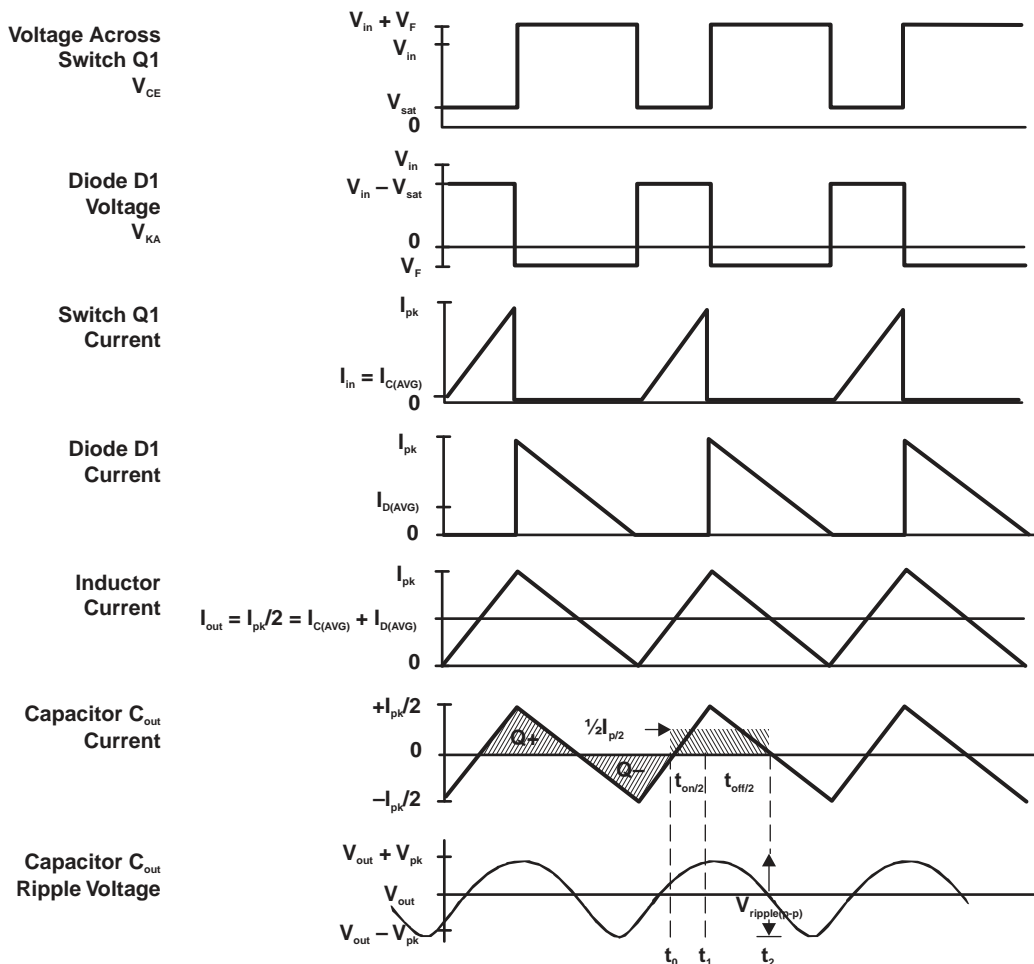

Figure 15. Buck Switching Regulator Waveforms

8.2.3 Voltage Inverter Converter

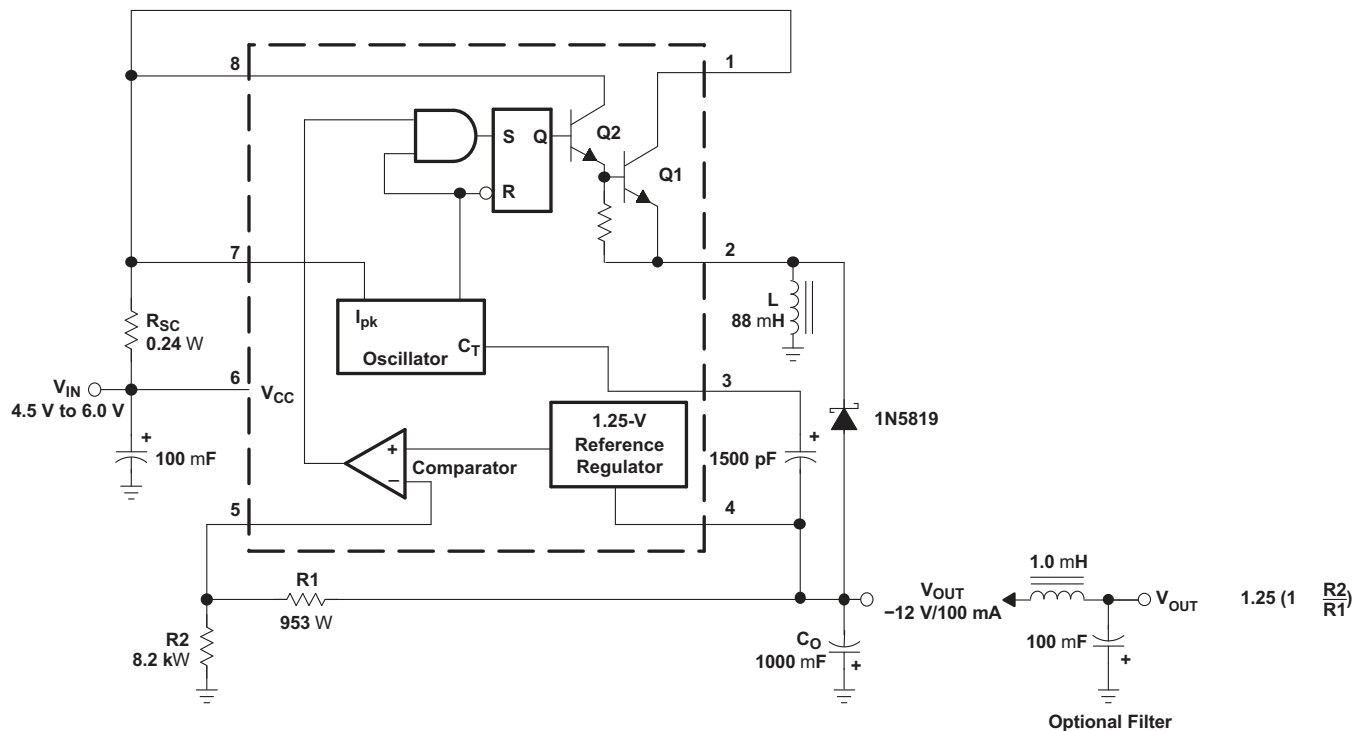

Figure 16. Voltage-Inverting Converter

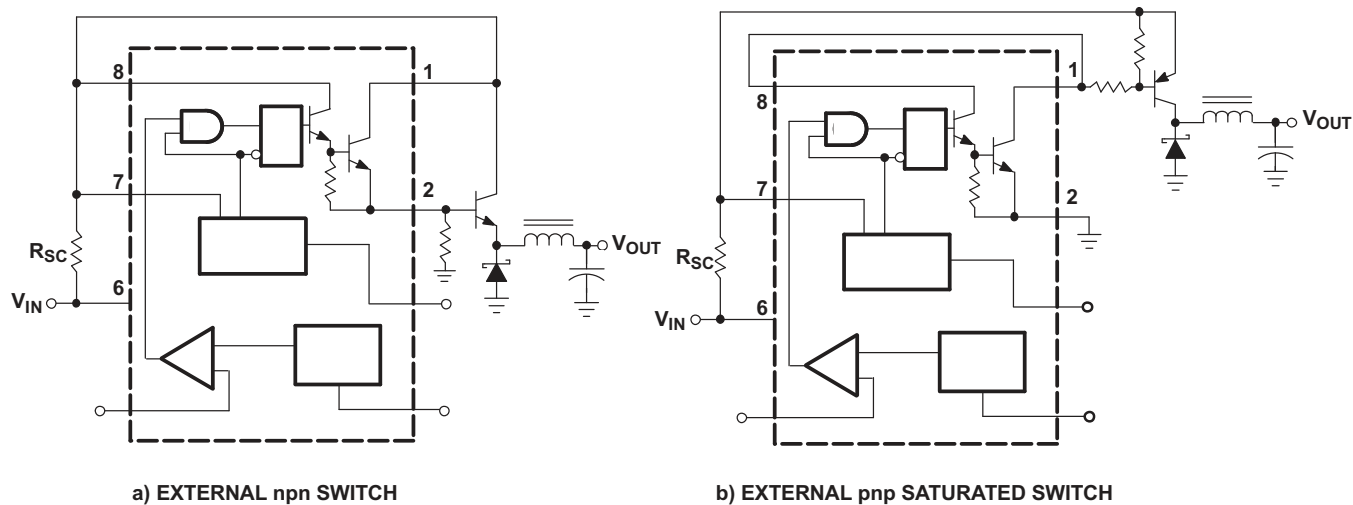

Figure 17. External Current-Boost Connections for Voltage Inverter Converter

8.2.3.1 Design Requirements

TEST	CONDITIONS	RESULTS
Line regulation	$V_{IN} = 4.5\text{ V to }6\text{ V}, I_O = 100\text{ mA}$	$3\text{ mV} \pm 0.12\%$
Load regulation	$V_{IN} = 5\text{ V}, I_O = 10\text{ mA to }100\text{ mA}$	$0.022\text{ V} \pm 0.09\%$
Output ripple	$V_{IN} = 5\text{ V}, I_O = 100\text{ mA}$	500 mVPP
Short-circuit current	$V_{IN} = 5\text{ V}, R_L = 0.1\ \Omega$	910 mA
Efficiency	$V_{IN} = 5\text{ V}, I_O = 100\text{ mA}$	62.2%
Output ripple with optional filter	$V_{IN} = 5\text{ V}, I_O = 100\text{ mA}$	70 mVPP

8.2.3.2 Detailed Design Procedure

See [Detailed Design Procedure](#).

8.2.3.3 Application Curves

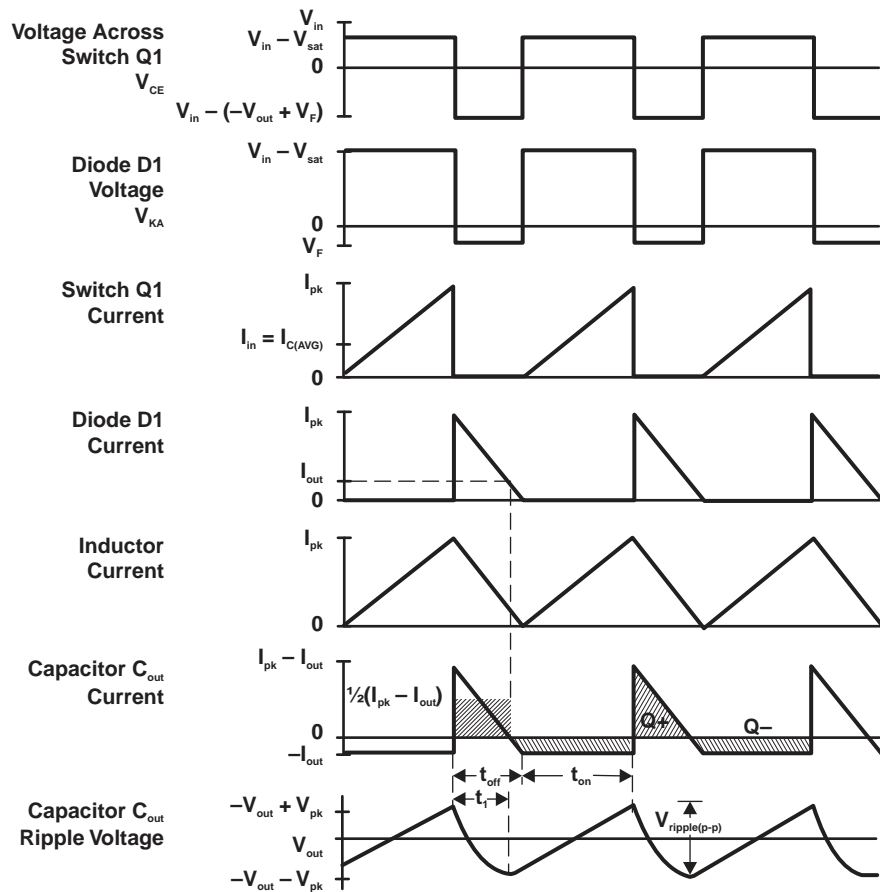

Figure 18. Inverter Switching Regulator Waveforms

8.2.4 12 V Battery Based Automotive Supply

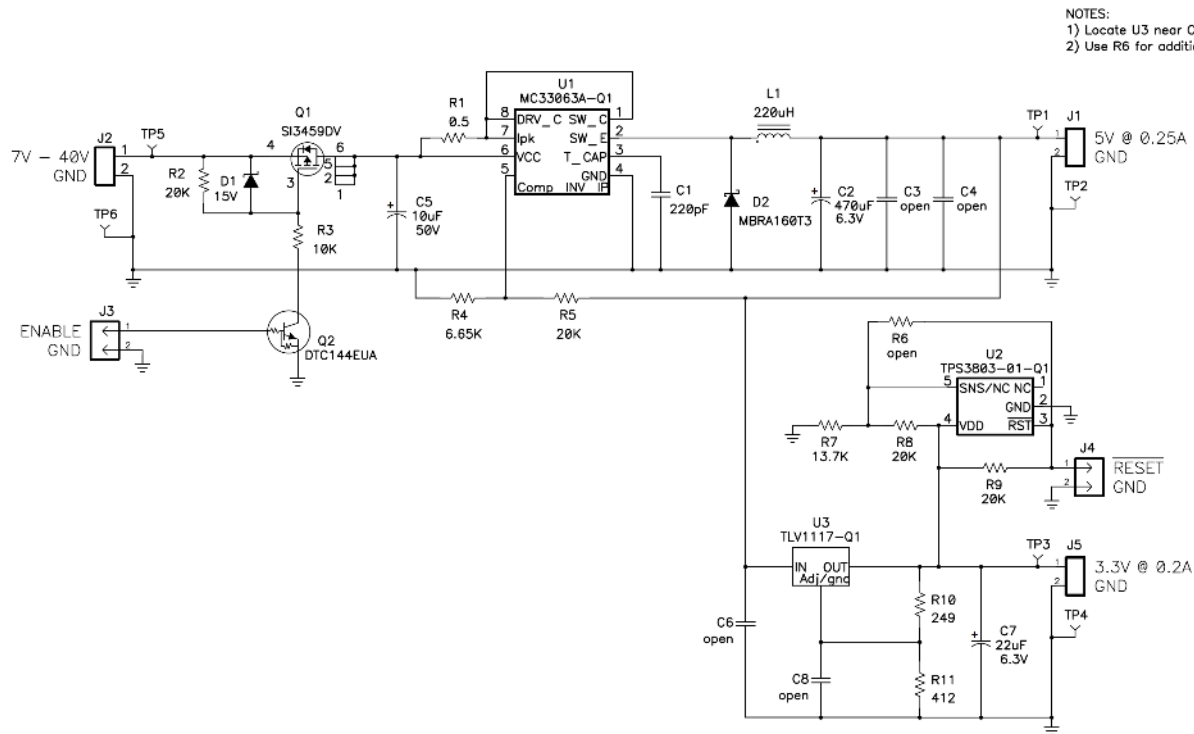

Figure 19. 12 V Battery Based Automotive Supply Schematic

8.2.4.1 Design Requirements

Input Supply Voltage: 7 to 40 V

Output Supply Voltage: 5 V at 0.25 A

An additional supply rail of 3.3 at 0.2 A along with a power supply supervisor is required for this application.

8.2.4.2 Detailed Design Procedure

See [Detailed Design Procedure](#).

8.2.4.3 Application Curve

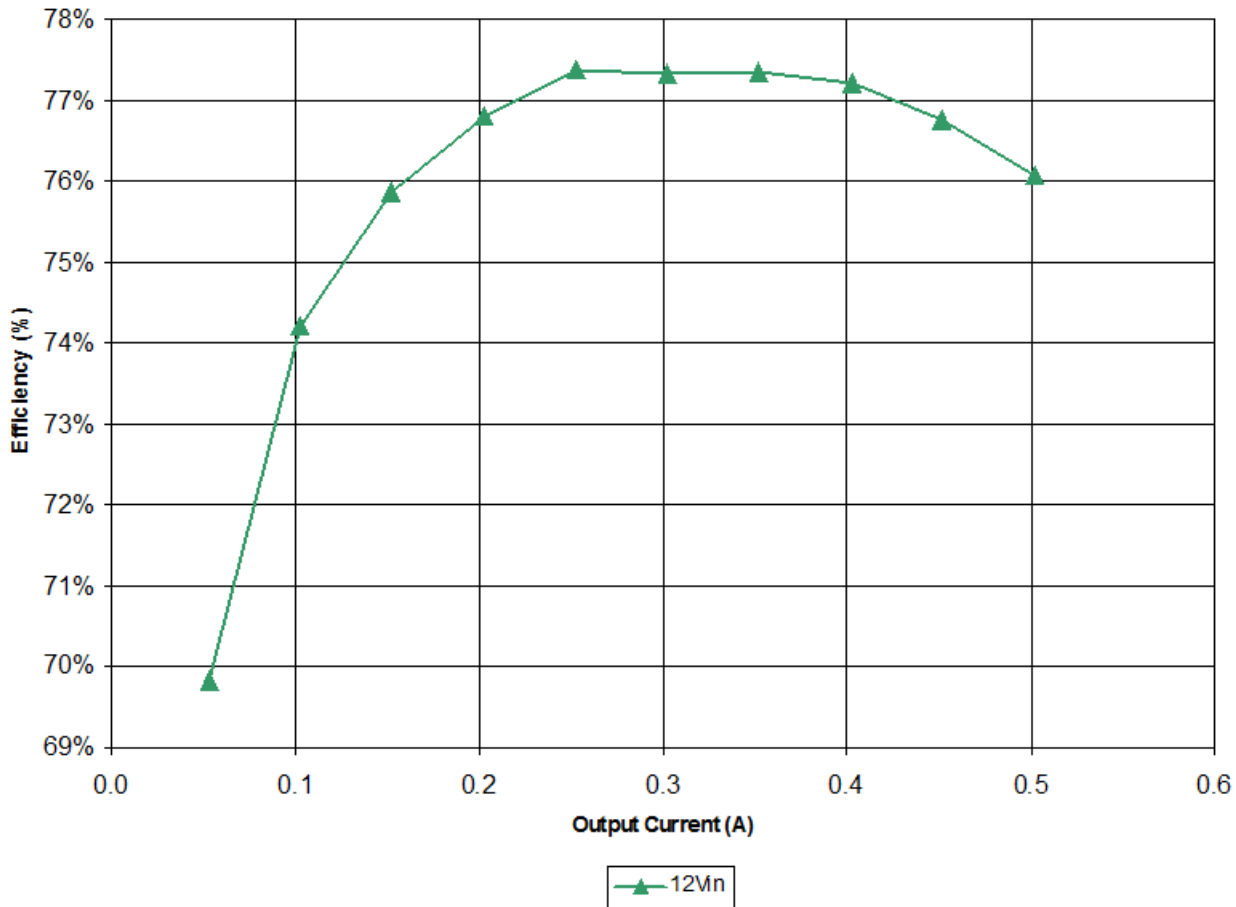

Figure 20. Application Example 4 Efficiency

9 Power Supply Recommendations

The input decoupling capacitors must be located as close as possible to the MC33063-Q1. In addition, the voltage set-point resistor divider components must also be kept close to the IC to eliminate any noise pick-up into the feedback loop.

10 Layout

10.1 Layout Guidelines

Layout is a critical portion of good power supply design. There are several signals paths that conduct fast changing currents or voltages that can interact with stray inductance or parasitic capacitance to generate noise or degrade the power supplies performance. To help eliminate these problems, the input voltage pin should be bypassed to ground with a low ESR ceramic bypass capacitor with X5R or X7R dielectric. Care should be taken to minimize the loop area formed by the bypass capacitor connections, the input pin, and the anode of the catch diode.

10.2 Layout Example

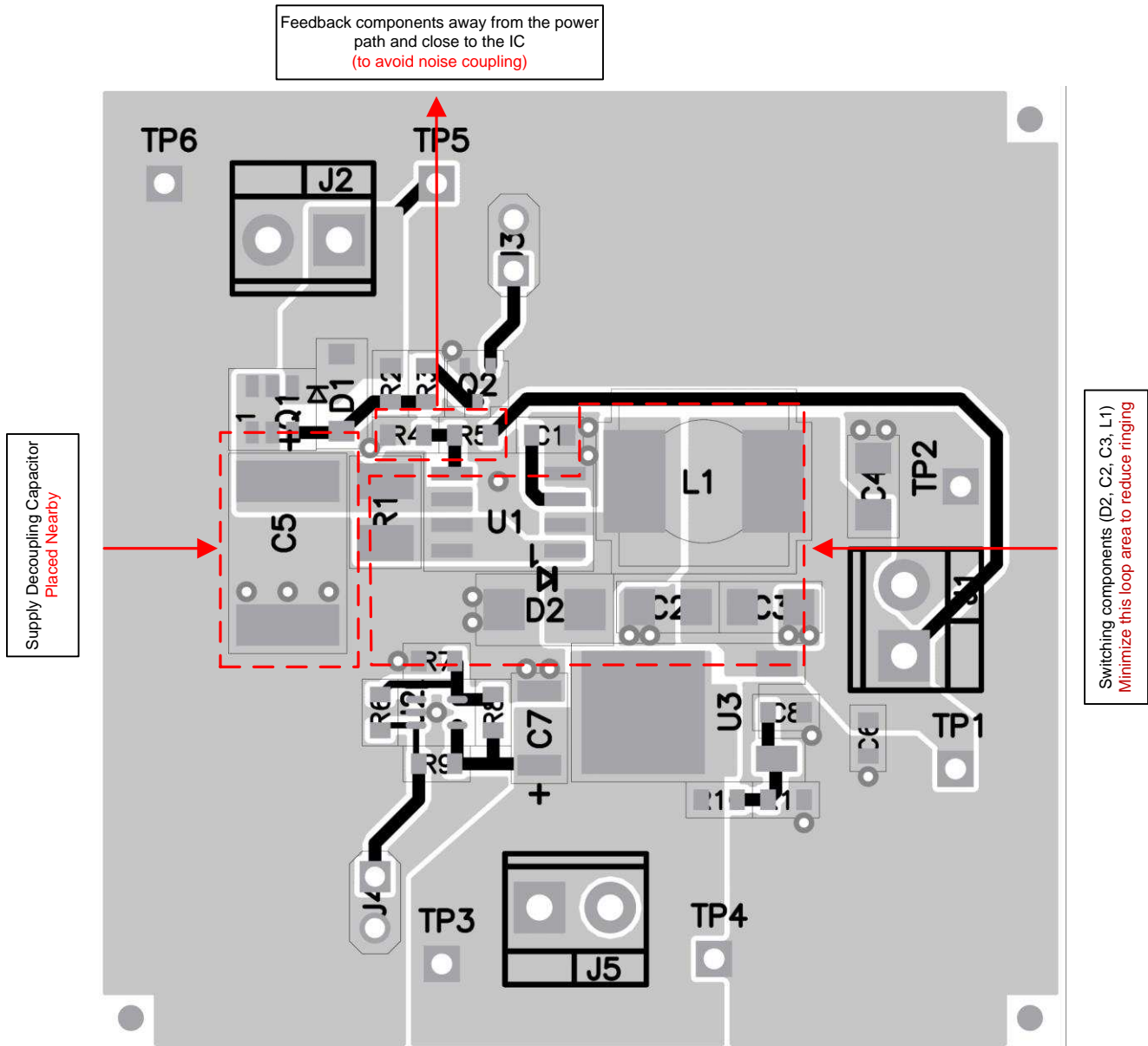

Figure 21. MC33063A-Q1 Layout Top Layer Example

Layout Example (continued)

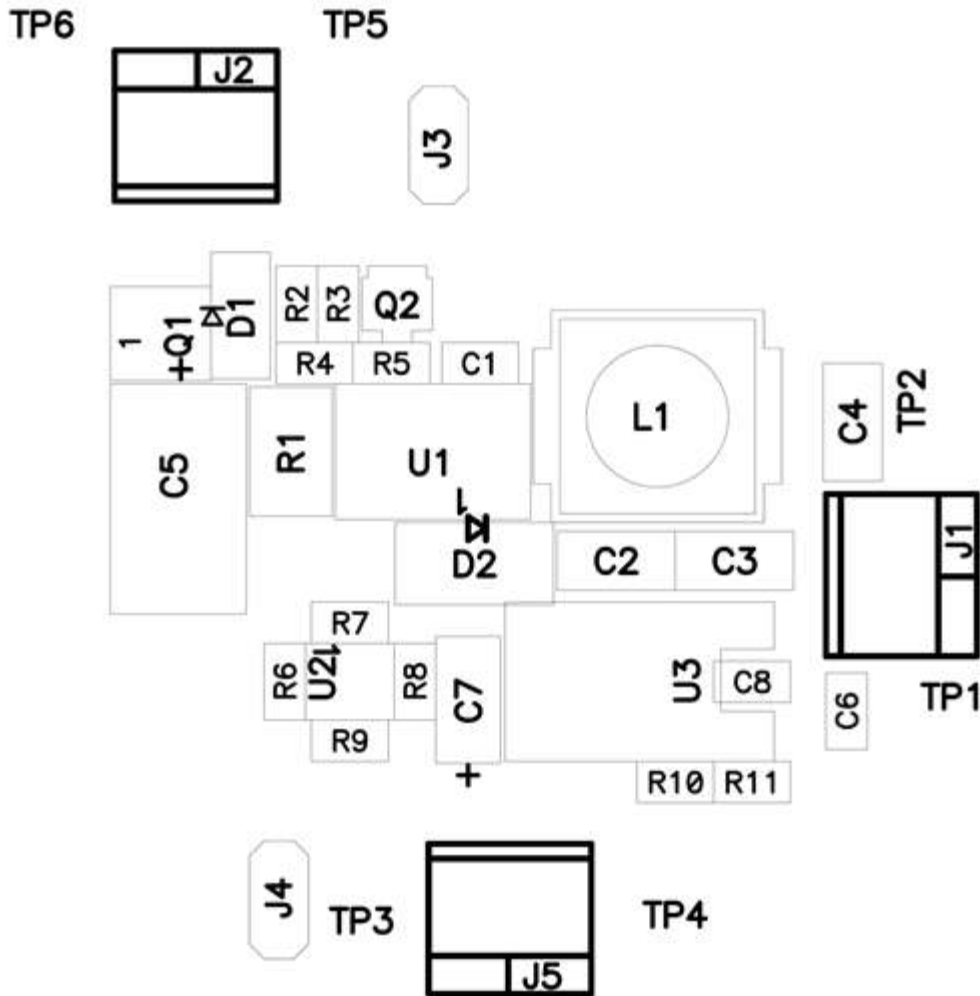

Figure 22. MC33063A-Q1 Layout Middle Layer Example

Layout Example (continued)

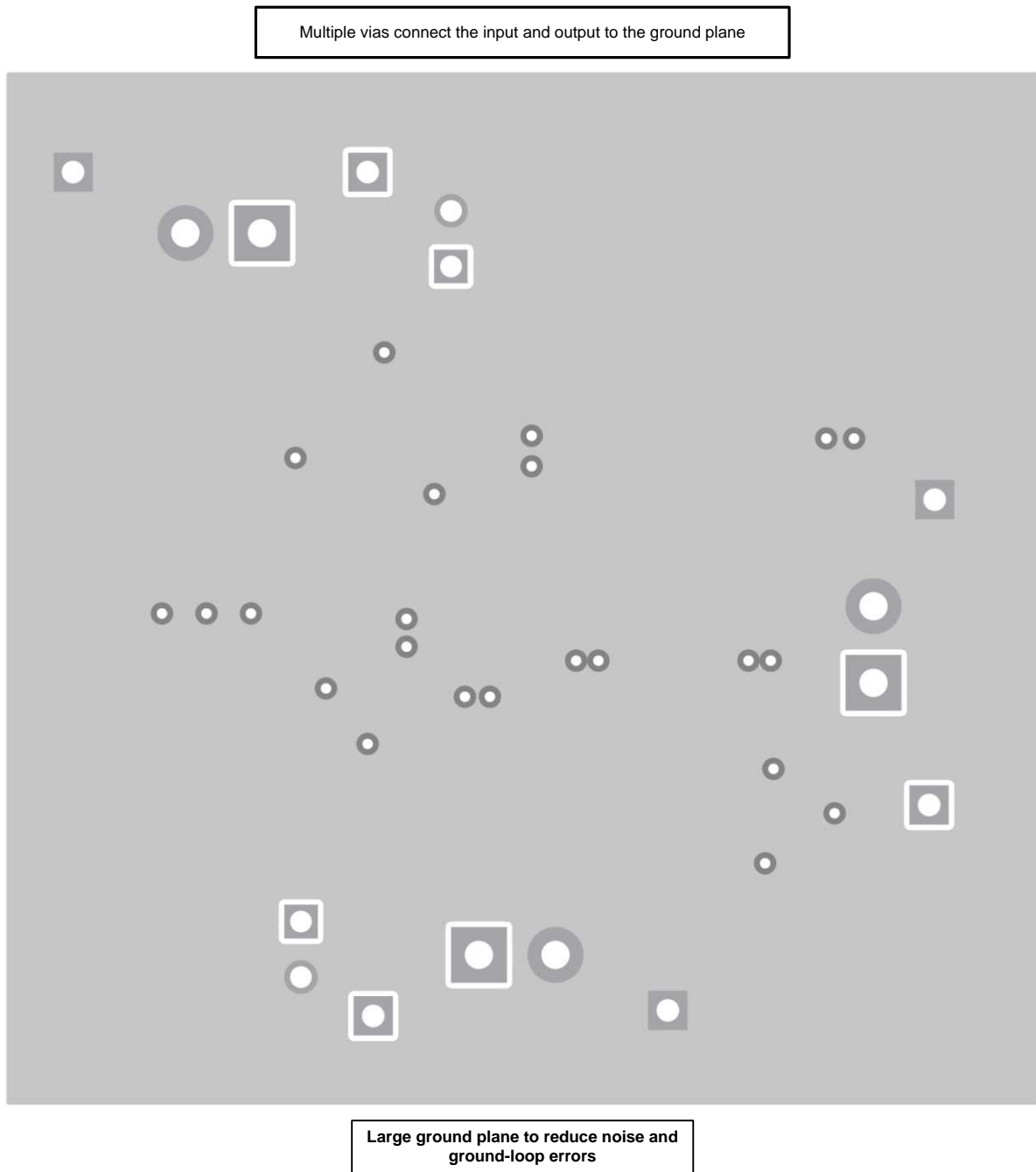

Figure 23. MC33063A-Q1 Layout Bottom Layer Example

11 Device and Documentation Support

11.1 Trademarks

All trademarks are the property of their respective owners.

11.2 Electrostatic Discharge Caution



These devices have limited built-in ESD protection. The leads should be shorted together or the device placed in conductive foam during storage or handling to prevent electrostatic damage to the MOS gates.

11.3 Glossary

[SLYZ022](#) — *TI Glossary*.

This glossary lists and explains terms, acronyms, and definitions.

12 Mechanical, Packaging, and Orderable Information

The following pages include mechanical, packaging, and orderable information. This information is the most current data available for the designated devices. This data is subject to change without notice and revision of this document. For browser-based versions of this data sheet, refer to the left-hand navigation.

PACKAGING INFORMATION

Orderable Device	Status (1)	Package Type	Package Drawing	Pins	Package Qty	Eco Plan (2)	Lead finish/ Ball material (6)	MSL Peak Temp (3)	Op Temp (°C)	Device Marking (4/5)	Samples
MC33063AQDRQ1	ACTIVE	SOIC	D	8	2500	RoHS & Green	NIPDAU	Level-1-260C-UNLIM	-40 to 125	33063AQ	Samples

(1) The marketing status values are defined as follows:

ACTIVE: Product device recommended for new designs.

LIFEBUY: TI has announced that the device will be discontinued, and a lifetime-buy period is in effect.

NRND: Not recommended for new designs. Device is in production to support existing customers, but TI does not recommend using this part in a new design.

PREVIEW: Device has been announced but is not in production. Samples may or may not be available.

OBSOLETE: TI has discontinued the production of the device.

(2) **RoHS:** TI defines "RoHS" to mean semiconductor products that are compliant with the current EU RoHS requirements for all 10 RoHS substances, including the requirement that RoHS substance do not exceed 0.1% by weight in homogeneous materials. Where designed to be soldered at high temperatures, "RoHS" products are suitable for use in specified lead-free processes. TI may reference these types of products as "Pb-Free".

RoHS Exempt: TI defines "RoHS Exempt" to mean products that contain lead but are compliant with EU RoHS pursuant to a specific EU RoHS exemption.

Green: TI defines "Green" to mean the content of Chlorine (Cl) and Bromine (Br) based flame retardants meet JS709B low halogen requirements of <=1000ppm threshold. Antimony trioxide based flame retardants must also meet the <=1000ppm threshold requirement.

(3) MSL, Peak Temp. - The Moisture Sensitivity Level rating according to the JEDEC industry standard classifications, and peak solder temperature.

(4) There may be additional marking, which relates to the logo, the lot trace code information, or the environmental category on the device.

(5) Multiple Device Markings will be inside parentheses. Only one Device Marking contained in parentheses and separated by a "-" will appear on a device. If a line is indented then it is a continuation of the previous line and the two combined represent the entire Device Marking for that device.

(6) Lead finish/Ball material - Orderable Devices may have multiple material finish options. Finish options are separated by a vertical ruled line. Lead finish/Ball material values may wrap to two lines if the finish value exceeds the maximum column width.

Important Information and Disclaimer: The information provided on this page represents TI's knowledge and belief as of the date that it is provided. TI bases its knowledge and belief on information provided by third parties, and makes no representation or warranty as to the accuracy of such information. Efforts are underway to better integrate information from third parties. TI has taken and continues to take reasonable steps to provide representative and accurate information but may not have conducted destructive testing or chemical analysis on incoming materials and chemicals. TI and TI suppliers consider certain information to be proprietary, and thus CAS numbers and other limited information may not be available for release.

In no event shall TI's liability arising out of such information exceed the total purchase price of the TI part(s) at issue in this document sold by TI to Customer on an annual basis.

OTHER QUALIFIED VERSIONS OF MC33063A-Q1 :

- Catalog: [MC33063A](#)

NOTE: Qualified Version Definitions:

- Catalog - TI's standard catalog product



D0008A

PACKAGE OUTLINE

SOIC - 1.75 mm max height

SMALL OUTLINE INTEGRATED CIRCUIT



NOTES:

1. Linear dimensions are in inches [millimeters]. Dimensions in parenthesis are for reference only. Controlling dimensions are in inches. Dimensioning and tolerancing per ASME Y14.5M.
2. This drawing is subject to change without notice.
3. This dimension does not include mold flash, protrusions, or gate burrs. Mold flash, protrusions, or gate burrs shall not exceed .006 [0.15] per side.
4. This dimension does not include interlead flash.
5. Reference JEDEC registration MS-012, variation AA.

EXAMPLE BOARD LAYOUT

D0008A

SOIC - 1.75 mm max height

SMALL OUTLINE INTEGRATED CIRCUIT

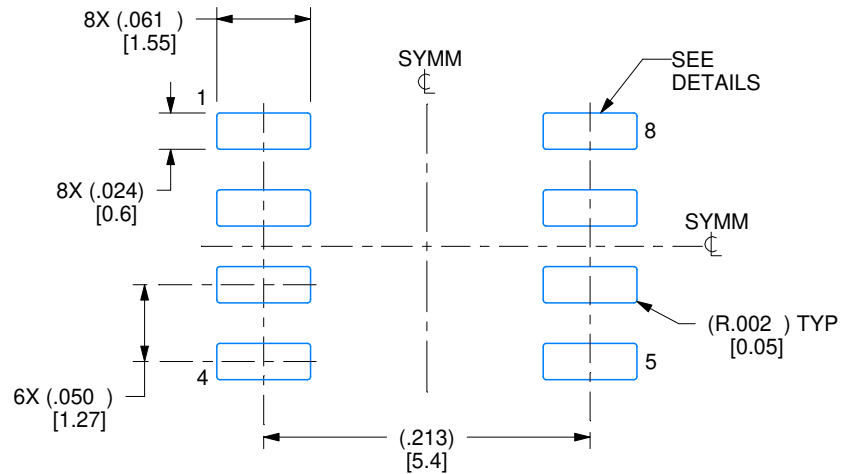

LAND PATTERN EXAMPLE
EXPOSED METAL SHOWN
SCALE:8X

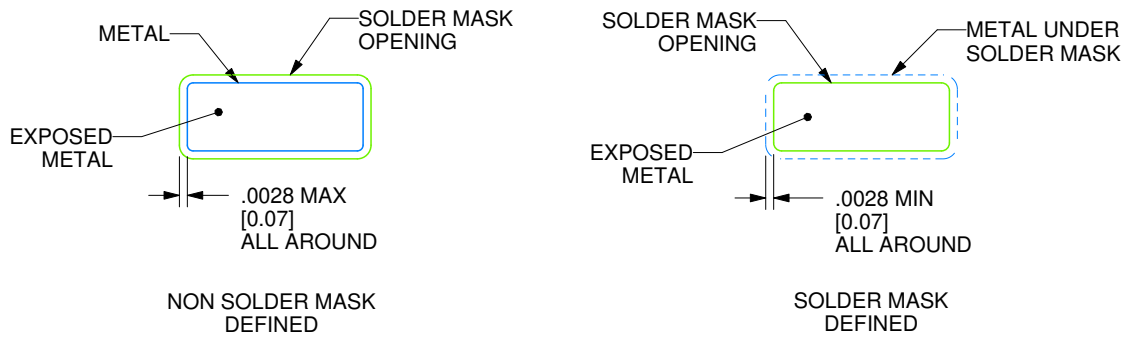

SOLDER MASK DETAILS

4214825/C 02/2019

NOTES: (continued)

6. Publication IPC-7351 may have alternate designs.

7. Solder mask tolerances between and around signal pads can vary based on board fabrication site.

EXAMPLE STENCIL DESIGN

D0008A

SOIC - 1.75 mm max height

SMALL OUTLINE INTEGRATED CIRCUIT



SOLDER PASTE EXAMPLE
BASED ON .005 INCH [0.125 MM] THICK STENCIL
SCALE:8X

4214825/C 02/2019

NOTES: (continued)

8. Laser cutting apertures with trapezoidal walls and rounded corners may offer better paste release. IPC-7525 may have alternate design recommendations.
9. Board assembly site may have different recommendations for stencil design.

IMPORTANT NOTICE AND DISCLAIMER

TI PROVIDES TECHNICAL AND RELIABILITY DATA (INCLUDING DATASHEETS), DESIGN RESOURCES (INCLUDING REFERENCE DESIGNS), APPLICATION OR OTHER DESIGN ADVICE, WEB TOOLS, SAFETY INFORMATION, AND OTHER RESOURCES "AS IS" AND WITH ALL FAULTS, AND DISCLAIMS ALL WARRANTIES, EXPRESS AND IMPLIED, INCLUDING WITHOUT LIMITATION ANY IMPLIED WARRANTIES OF MERCHANTABILITY, FITNESS FOR A PARTICULAR PURPOSE OR NON-INFRINGEMENT OF THIRD PARTY INTELLECTUAL PROPERTY RIGHTS.

These resources are intended for skilled developers designing with TI products. You are solely responsible for (1) selecting the appropriate TI products for your application, (2) designing, validating and testing your application, and (3) ensuring your application meets applicable standards, and any other safety, security, or other requirements. These resources are subject to change without notice. TI grants you permission to use these resources only for development of an application that uses the TI products described in the resource. Other reproduction and display of these resources is prohibited. No license is granted to any other TI intellectual property right or to any third party intellectual property right. TI disclaims responsibility for, and you will fully indemnify TI and its representatives against, any claims, damages, costs, losses, and liabilities arising out of your use of these resources.

TI's products are provided subject to TI's Terms of Sale (www.ti.com/legal/termsofsale.html) or other applicable terms available either on ti.com or provided in conjunction with such TI products. TI's provision of these resources does not expand or otherwise alter TI's applicable warranties or warranty disclaimers for TI products.

Mailing Address: Texas Instruments, Post Office Box 655303, Dallas, Texas 75265
Copyright © 2020, Texas Instruments Incorporated