

DEVICE SPECIFICATION FOR PYRO-ELECTRIC IR-DETECTOR

Customer :
Type : PYQ 1648
Part no. : 7052
No. of samples:

Four element detector, serial opposed format, four elements based on pyroceramic. The signal is converted to a digital value using Sigma-Delta and DSP techniques.

This specification is provided by

Excelitas Technologies GmbH & Co. KG, Wiesbaden.

It covers the complete technical data of a pyro-electric IR detector. In case of samples attached to this paper, these have been taken randomly from normal production output. All detectors have met the requirements of Excelitas test-specifications and passed outgoing inspection.

We kindly ask for approval with the return of a signed copy.

Checked:

Date: 21.07.2016

Customer approval:

Date:

Electrical Configuration:

The pyro-electric sensing elements are connected to a built-in IC, whose detailed description follows:

The Low Power DigiPyro[®] contains the IR radiation sensitive Pyroelements and an ASIC for the digital signal processing within the TO housing. The ASIC includes on-chip an oscillator, a voltage reference, an analog-to-digital converter with multiplexed inputs for the Pyroelements and for the internal temperature sensor. Included are also Low- and High-Pass Filters and a Motion Detection Unit. A serial interface “SERIN” is provided to input configuration settings to internal registers (volatile). A second serial interface “DIRECT LINK” to read back the register settings and to output the processed digital signal from the ADC as a bitstream is also included. A block diagram of the device is shown below.

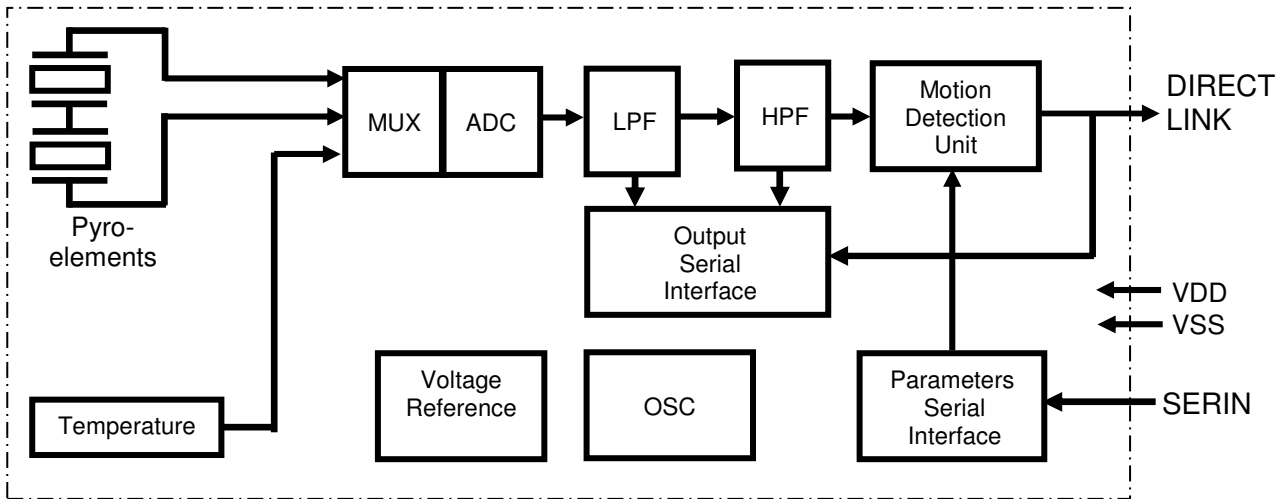

Fig. 1: Block Diagram

Alarm Event Unit Configuration Register

Bit-No	Register / Range	Name	Remarks
[24:17]	[7:0] / 0 ... 255	Sensitivity	This value defines the threshold for detection
[16:13]	[3:0] / 0 ... 15	Blind Time	No motion detection for the time programmed (0.5s .. 8s) after DIRECT LINK changed from "H" to "L". Blind time = 0.5s + [RegisterValue] * 0.5s
[12:11]	[1:0] / 0 ... 3	Pulse Counter	Amount of pulses with sign change during the specified time window which triggers an alarm event (DIRECT LINK changes from "L" to "H"). Number of pulses = 1 + [RegisterValue]
[10:9]	[1:0] / 0 ... 3	Window Time	Specifies the time window in which the amount of pulses will trigger an alarm event. Window time = 2s + [RegisterValue] * 2s
[8:7]	[0] / 0 ... 3	Operation Modes	0 = Forced Read Out Mode Interrupts (DIRECT LINK changes from "L" to "H") are not generated. 1 = Interrupt Read Out Mode Interrupts are generated approx. every 14ms (512 clock cycles). 2 = Wake Up Operation Mode An interrupt is generated when motion criteria are met. 3 = reserved
[6:5]	[1:0] / 0 ... 3	Filter Source	Following source voltages are selectable: 0 = PIR (BPF) 1 = PIR (LPF) 2 = reserved 3 = Temperature Sensor For Wake Up Operation Mode, "0x0 - BPF" or '0x1 - LPF' has to be selected. The motion detection criteria are applied on the band pass filtered PIR signal even though the filter source might be set to LPF.
[4:0]	[4:0] / 0 ... 31	reserved	Must be written to 16 decimal.

NOTE: Register contents are undefined after Power-Up.

The configuration data is transferred into the device via the serial input SERIN. The external microcontroller has to generate a “L” to “H” transition on the SERIN input and subsequently apply the data bit value (“L” or “H”).

The “L” and “H” time (t_{SL} and t_{SH}) for the transition can be very short (1 instruction cycle of the microcontroller). The data bit value must be applied for at least 2 system clocks ($t_{SHD} \geq 72\mu s$).

Whenever the device has received more than 25 data bits and the transfer of data bits is interrupted for a period greater than 16 system clocks ($t_{SLT} > 580\mu s$), the last data received is latched into the configuration register. The transmission of a 25 bit data should not be interrupted for more than 15 system clocks, as the device may latch the data already at this stage.

New data is soonest accepted when SERIN has been "L" for at least 16 system clocks and the supply voltage is above 2.5V after Power-Up.

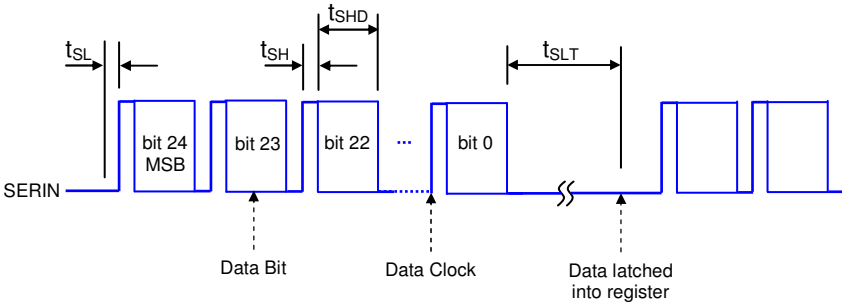

Fig. 2: Serial Data clocked into Device

Serial Data Output at DIRECTLINK

The serial output serves as an Interrupt output, indicating motion and as a serial output for reading status and configuration data from the circuit.

The PIR status, the ADC voltage as well as all internal data can be read through the DIRECTLINK interface. The sequence of the data starts with 15 bits representing PIR status and ADC voltage followed by 25 bits representing the configuration registers in the same order like in the programming mode at SERIN. The read procedure can be terminated at any point, it is not required to read all data.

Bit-No	Register / Range	Name	Remarks
[39]	[0] / 0 ... 1	Reserved	Not applicable
[38:25]	[13:0] / -8192 ... +8191 0 ... 16383	ADC Voltage	Either PIR - LPF / BPF or VTEMP Data in 14bit two's complement format when BPF active Data in unsigned 14bit format in all other cases
[24:0]	-	Configuration Registers	Register and Bit order as per table above

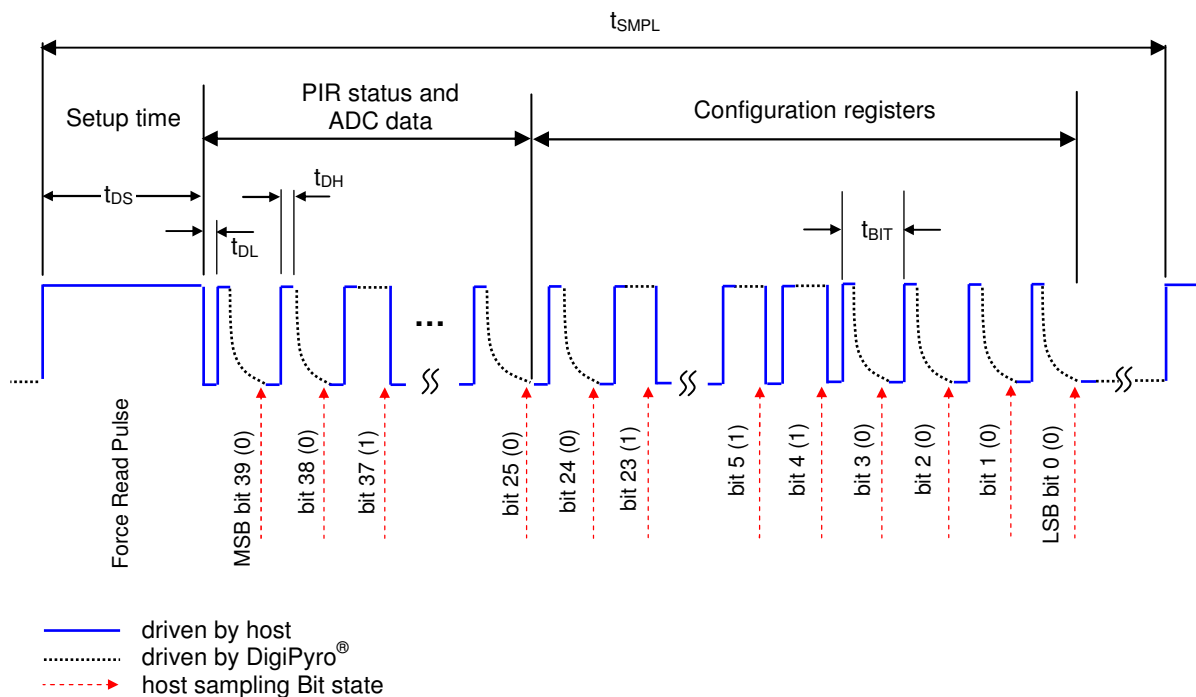

Fig. 3: Data Transmission Diagram

Read Out Procedure:

Forcing DIRECT LINK to HIGH for at least 3 f_{CLK} cycles (t_{DS}) will start the transmission from the DigiPyro[®]. After this setup time (t_{DS}) has passed the DigiPyro[®] expects a LOW to HIGH transition (t_{DL}, t_{DH}) on the DIRECT LINK pin and will subsequently output the data bit state. When a bit has been read, the DigiPyro[®] waits for the next LOW to HIGH transition and the sequence will be repeated until all bit are shifted out. After the last t_{bit} of bit[0] the host controller must force DIRECT LINK pin to LOW and subsequently release DIRECT LINK (High Z).

The time that the signal needs to settle to a LOW level depends on the capacitive load (e.g. PCB design) at the DIRECT LINK pin. Hence, it is recommended to start implementing the interface with t_{BIT} close to but shorter than 22 μ s to ensure proper LOW level settling. In next steps reduce t_{BIT} empirically to optimize for reliable data transmission at maximum transmission speed.

It has to be considered that t_{BIT} must not exceed $1/f_{CLK}$ (22 μ s) to avoid data corruption. (Under no circumstances DIRECT LINK may be at LOW level for longer than 22 μ s). Also, the total time to readout one data packet may not exceed 32 clock cycles (~800 μ s).

It is allowed to cancel the readout of a data packet after a certain number of bits have been read. To terminate the readout, DIRECT LINK must be forced to LOW level for at least 4 clock cycles (~145 μ s).

For example: reading only from bit[39] to bit[25] skips reading the configuration registers settings. After bit[25] has been read, DIRECT LINK must be held at LOW level and subsequently released (High Z).

Interrupt Output:

If the interrupt source is set to Filter, DIRECT LINK will be pulled HIGH every 512 clock cycles. The next data packet has to be read before this HIGH signal occurs ($t_{SMPL} < 512$ clock cycles).

If the interrupt source is set to the Motion Detection Unit, DIRECT LINK will be pulled HIGH when the motion criteria are met. DIRECT LINK will not automatically fall back to LOW. To clear the interrupt, DIRECT LINK needs to be pulled to LOW by the microcontroller for at least one system clock. When the alarm event is cleared by resetting the interrupt, any further motion detection is stopped for the programmed blind time.

Reading data in the interrupt mode may not start sooner than 75 μ s after the interrupt occurred and DIRECT LINK was HIGH. In that case it is not required to generate a setup pulse (Data Setup Time). The first LOW to HIGH transition initiates the DigiPyro[®] to output the MSB.

No interrupt will be generated while the microcontroller accesses the interface.

To avoid saturation of the detector the DigiPyro[®] contains an out of range detection logic. The input of the ADC is shorted for a duration of 512 system clocks when the digital values are above 15872 counts or below 511 counts.

Electrical Data:

Unless specified differently all data refers to 25 °C.

Tab. 1: Electrical data of ADC

Parameter	Symbol	Min.	Typ.	Max.	Unit	Remarks
Operating Voltage	V_{DD}	2.5	3.3	3.6	V	
Supply Current	I_{DD}		3	5	μA	$V_{DD} = 3V$, no load
SERIN						
Input Low Voltage	V_{SIL}			$0.2V_{DD}$	V	
Input High Voltage	V_{SIH}	$0.8V_{DD}$			V	
Input Current	I_{SI}	-1		+1	μA	$V_{SS} < V_{IN} < V_{DD}$
Data Clock Low Time	t_{SL}	200		2000	ns	
Data Clock High Time	t_{SH}	200		2000	ns	
Data In Hold Time	t_{SHD}	72			μs	
Data Load Time	t_{SLT}	580			μs	
DIRECT LINK						
Input Low Voltage	V_{DIL}			$0.2V_{DD}$	V	
Input High Voltage	V_{DIH}	$0.8V_{DD}$			V	
Input Current	I_{DI}	-1		+1	μA	
Data Setup Time	t_{DS}	110		150	μs	
Data Clock Low Time ¹	t_{DL}	200		2000	ns	
Data Clock High Time ¹	t_{DH}	200		2000	ns	
Sample Time	t_{SMPL}	2.0		12.5^3	ms	
Bit Time ¹	t_{BIT}			22	μs	
ADC Resolution ²						
			14		Bits	Max Count = $2^{14} - 1$
PIR ADC Sensitivity			6.5		$\mu V/Count$	
PIR ADC Offset		7000	8000	9000	Counts	in stable condition
Sensitivity of T_{AMB} ²						
			80		Counts/K	
Counts at 300K (27 degrees C)		6620	8200	9980	Counts	
LPF cutoff frequency						
	f_1		7		Hz	
HPF cutoff frequency						
	f_2		0.44		Hz	
Internal Clock Frequency						
	f_{CLK}	28	32	40	kHz	

¹ DL must not be longer than 22 μs at Low level ($t_{BIT} - t_{DH} < 22\mu s$) to avoid data corruption.

² ADC output ranges from 511 to (2^{14}) - 511 counts.

³ Maximum Limit only applicable in "Interrupt Read Out Mode".

Responsivity: **min.: 5.4 kV/W** **typ.: 6.5 kV/W**

Responsivity is measured within spectral range 7 - 14 μm as per fig. 3 at 1Hz.

Match: **max.: 10 %**

Electrical balance (match) is measured with same test set up as responsivity, both elements exposed to radiation. A percent value is calculated as

$$\frac{100 \times S_m}{s}$$

S_m : signal (match)

s : signal of left or right element.

Noise: **max.: 160 μV_{pp}** **typ.: 40 μV_{pp}**

After a 10 minute settling time, noise is monitored for the duration of 1500 sec. at a temperature of 25°C, shut from infrared energy, digital filter between 0.4 to 10Hz.

Typical Responsivity vs. Frequency

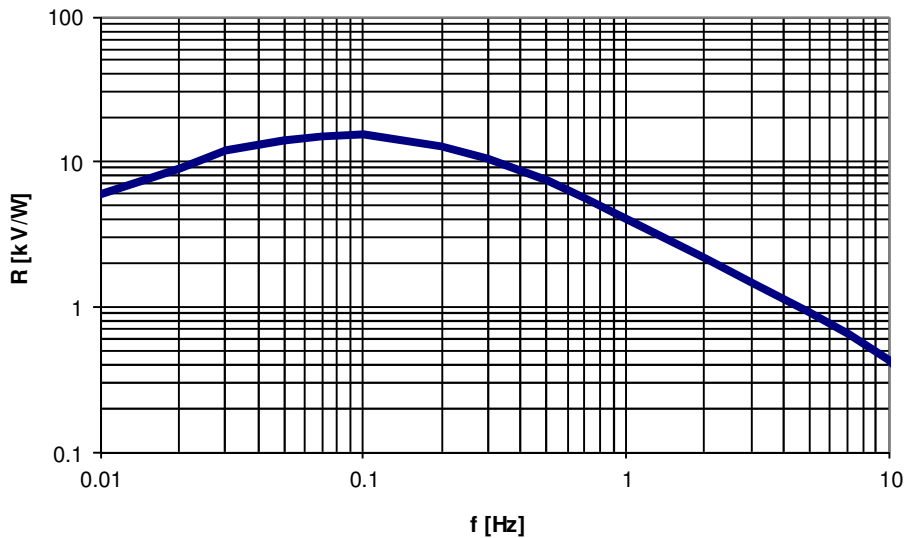

Fig. 4: Frequency response

Sample data

The samples attached to this specification have been tested. Test equipment as per fig.5 and fig.6.

Tab.2: Sample data

Sample no.	RA [kV/W]	RB [kV/W]	RC [kV/W]	RD [kV/W]	Match [kV/W]
1					
2					
3					
4					
5					
6					
7					
8					
9					
10					

Test Set up

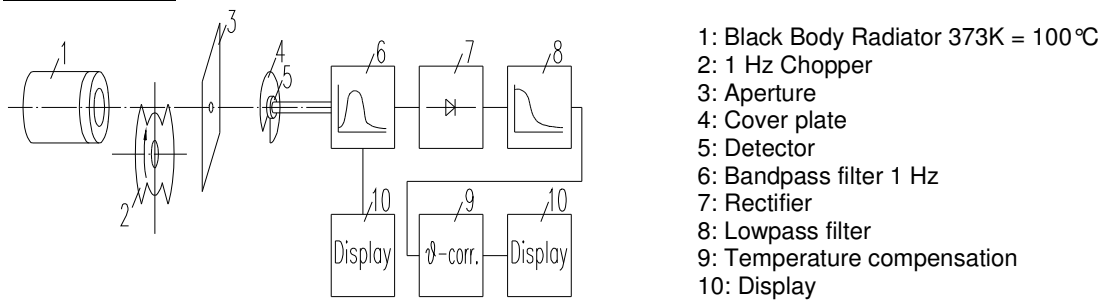

Fig. 5: Test Set – up

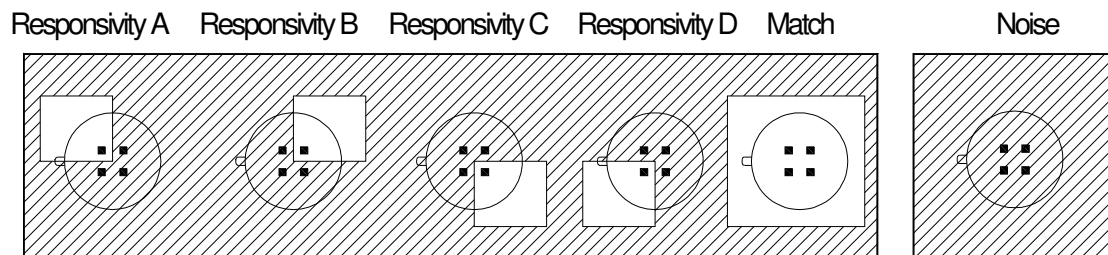

Fig. 6: Responsivity measurement

Spectral range:

The spectral range of the detector is determined by the built-in filter (window).

Substrate: Silicon, multilayer coated

Cut – on: 5.5 ± 0.3 μm

Transmission: T > 77% average between 7 μm and 14 μm

Blocking: T < 0.1% for λ < 5 μm

Physical Configuration:

Housing: TO- 5 metal housing with infrared transparent window

Element size: 1 x 1, see also drawing: 2/72339

Connections: Refer to drawing: 2/72339

Field of View

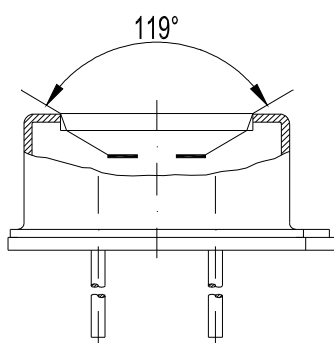

Fig. 7: Field of View

Operating temperature: -40 °C to +85 °C

The electrical parameters may vary from specified values accordance with their temperature dependence.

Storage temperature: -40 °C to +85 °C

Avoid storage under high humid environment.

Microphonic noise: max: 30 μV_{rms} /g

Excelitas IR-detectors covered herein have passed qualification test for microphonic noise in x-y-z axis, exciting frequencies from 5Hz to 2kHz.

Humidity:

The IR-detector shall not increase noise or decrease responsivity when exposed to 95% R.H. at 30 °C. Operation below dew point might affect performance.

Hermetic seal:

This IR-detector is sealed to pass a He-leakage test with maximum leak rate of 10^{-8} mbar.l.s⁻¹.

Quality:

Excelitas Technologies is a **ISO 9001** certified manufacturer with established SPC and TQM. Detector out-going inspections include the parameters Responsivity, Match, Offset, Noise, Gross leak (Mil Std 883 method 1014C1). Individual data are not stored, statistical details can be disclosed on request.

Handling:

Handle the detectors as ESD sensitive devices and protect them from electrostatic discharges. Working areas should be conductive and grounded. When handling detectors, operators shall be grounded. Avoid mechanical stress on the housing and especially on the leads. Be careful when cutting or bending leads to avoid damage. Do not bend leads less than 5 mm from their base. Do not drop detectors on the floor.

Avoid touching the detector window. To clean windows, only use ethyl alcohol with a cotton swab when necessary. Do not expose detector to aggressive detergents such as Freon, trichloroethylene, etc.

Soldering conditions:

For the soldering of the detectors within PCBs, the typically applied and recommended process is wave soldering. The soldering temperature should not exceed 285° C with a maximum exposure time of 5 seconds. During the automatic wave solder process we strongly advise to restrict preheating when the detector is directly exposed to the radiation of such heaters. In this case, the detector should be protected from the heat.

Manual soldering is also possible when maintaining similar temperature profiles. Reflow soldering is not possible due to the high temperature profiles of the process.

Product Safety & RoHS:

Modern high-tech materials are applied in the production of our pyro-electric detectors. Some of these materials are sensitive to high temperature exposure or to specific forms of stress. Our parts are compliant with environmental regulations as can be reviewed on the Excelitas website. We recommend to always check your local regulations. Disposal shall only be carried out in accordance with the latest legislation and directives. In Europe, WEEE directives must be followed.

The leads of these detectors have been pre-tinned with lead free tin process and may be applied through lead-free solder processes. As such the detectors will enable the design of RoHS compliant products.

Marking:

The marking of the detector includes the principal type plus a 4 digit number that represents the Excelitas storage and specification number (3XXX) and a date code, consisting of years and week detail. The marking is on the top or side of the detector.

Performance Advice

Before taking a reading, during testing, and / or operation the unit has to become thermally stable due to its nature as a thermal detector and the high sensitivity of the device.

All data are specified at room temperature. When operating at other temperatures within the specified operating range, parameters may vary. The detectors might operate outside the quoted range but may have degraded performance.

The reproduction, transmission or use of this document or its contents is not permitted without express written authority. Offenders will be liable for damages. All rights, including rights created by patent grant or registration of a utility model or design are reserved.

Weitergabe sowie Vervielfältigung dieser Unterlage, Verwertung und Mitteilung ihres Inhalts ist nicht gestattet, soweit nicht ausdrücklich zugestanden. Zuwiderhandlungen verpflichten zu Schadenersatz. Alle Rechte vorbehalten, insbesondere für den Fall der Patenterteilung oder GM-Eintragung.

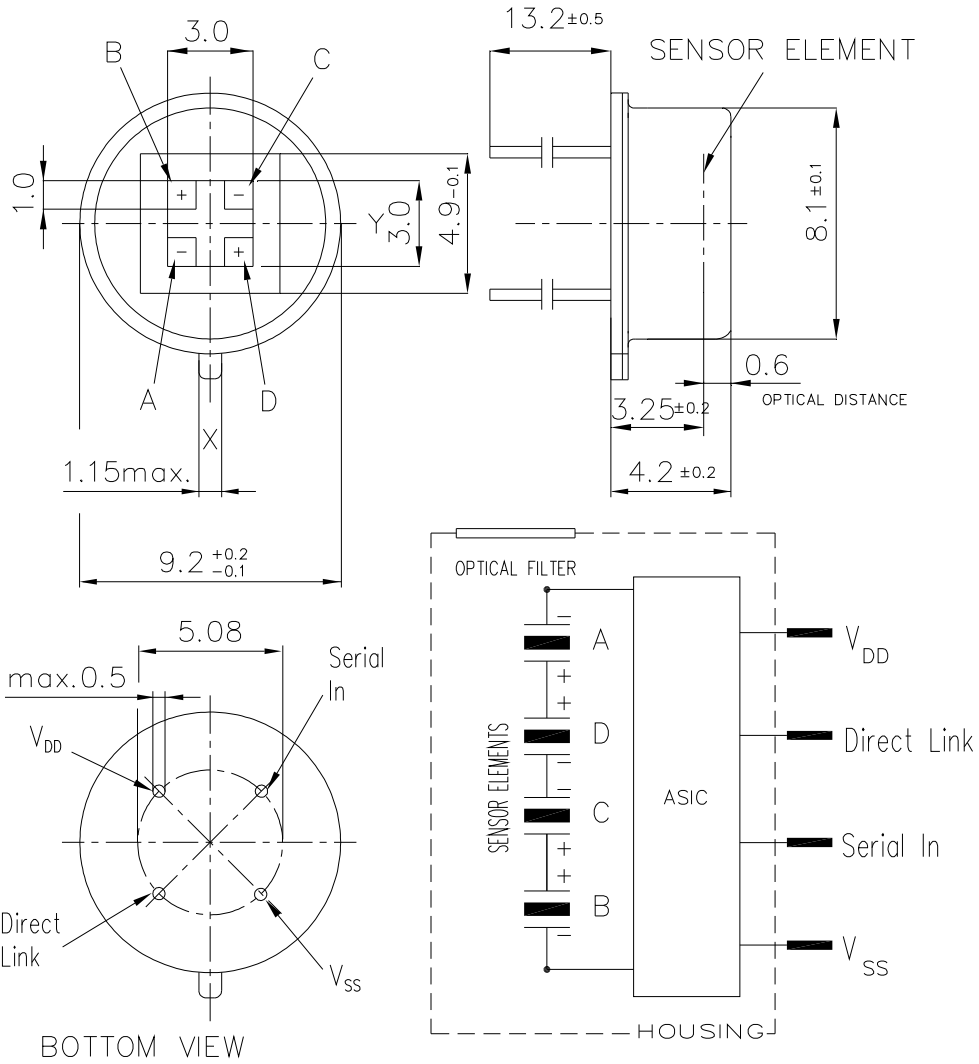

Allgemeintoleranzen GENERAL TOLERANCES				Werkstückkanten/EDGES OF WORKING-PARTS ACC. DIN 6174		Form- u. Lagetoleranzen GEOMETRICAL TOLERANCES	
				Datum DATE	Name NAME	Werkstoff MATERIAL	
Gez. DRAWN BY				09.06.2015	Tkocz		
Gepr. CHECKED BY				21.07.2016			
Maßstab SCALE				Benennung/TITLE			
5:1				ELEMENTORIENTATION AND CONNECTIONS PYQ 1648/1548			
1 2/4342 21.07.2016 Tkocz				Zeichnung Nr./DRAWING NO.			
0 2/4303 09.06.2015 Tkocz				2/72339			
Index NO.				Ersatz für/REPLACEMENT FOR			
Änderung REVISION				Ersetzt durch/REPLACED BY			
Datum DATE							
Name NAME							



A4.dwg