

THIS DRAWING IS UNPUBLISHED. RELEASED FOR PUBLICATION  
 © COPYRIGHT BY TYCO ELECTRONICS CORPORATION. ALL INTERNATIONAL RIGHTS RESERVED.

| LOC | DIST | REVISIONS                 |           |      |      |
|-----|------|---------------------------|-----------|------|------|
| P   | LTR  | DESCRIPTION               | DATE      | DWN  | APVD |
| GP  | 00   |                           |           |      |      |
|     | A    | REVISED PER ECO-08-027698 | 13-NOV-08 | ZMRC | WJR  |

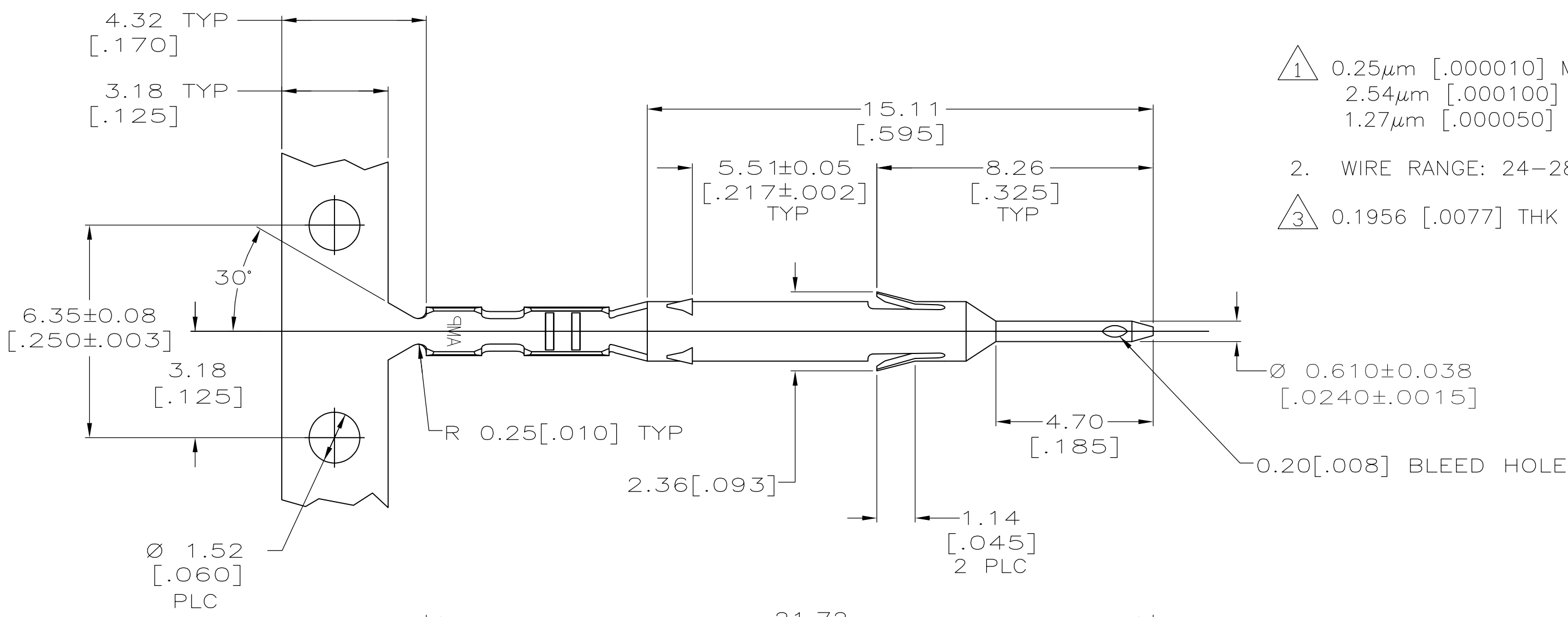

- 1 0.25µm [.000010] MIN GOLD IN LOCALIZED GOLD PLATE AREA, 2.54µm [.000100] MIN TIN IN LOCALIZED TIN PLATE, BOTH OVER 1.27µm [.000050] MIN NICKEL.
- 2. WIRE RANGE: 24-28; INSULATION RANGE: Ø0.51-0.76 [.020-.030].
- 3 0.1956 [.0077] THK BRASS PER ASTM B36.

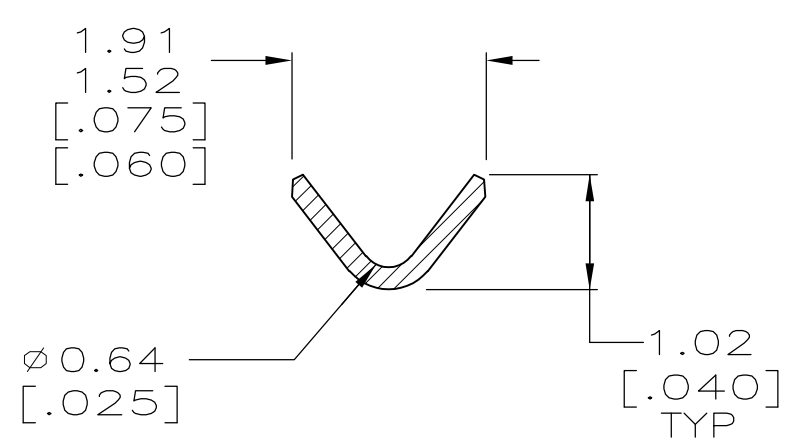
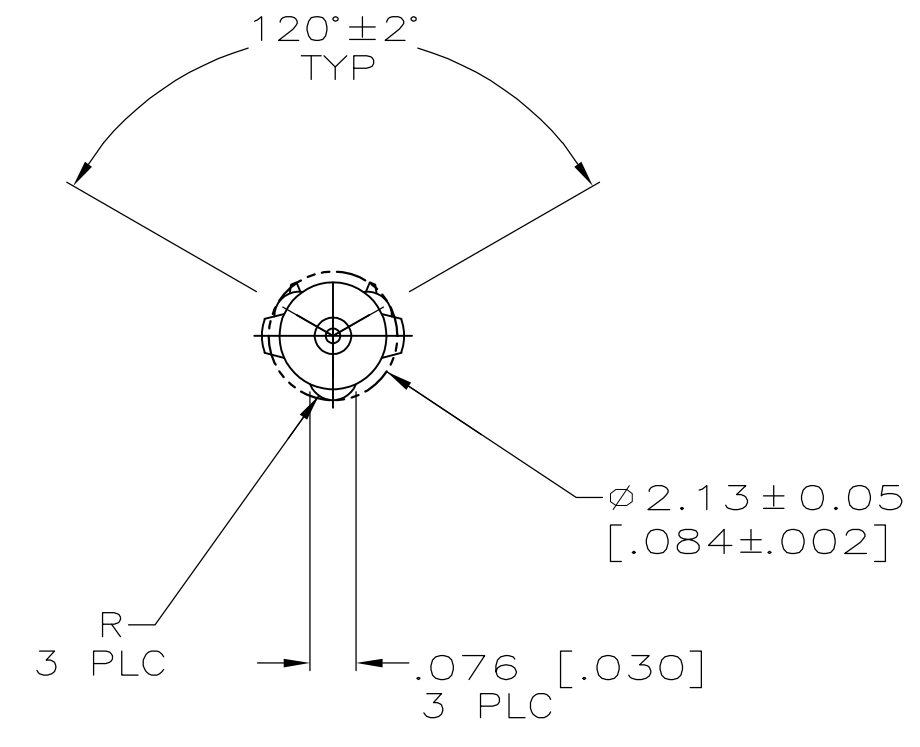
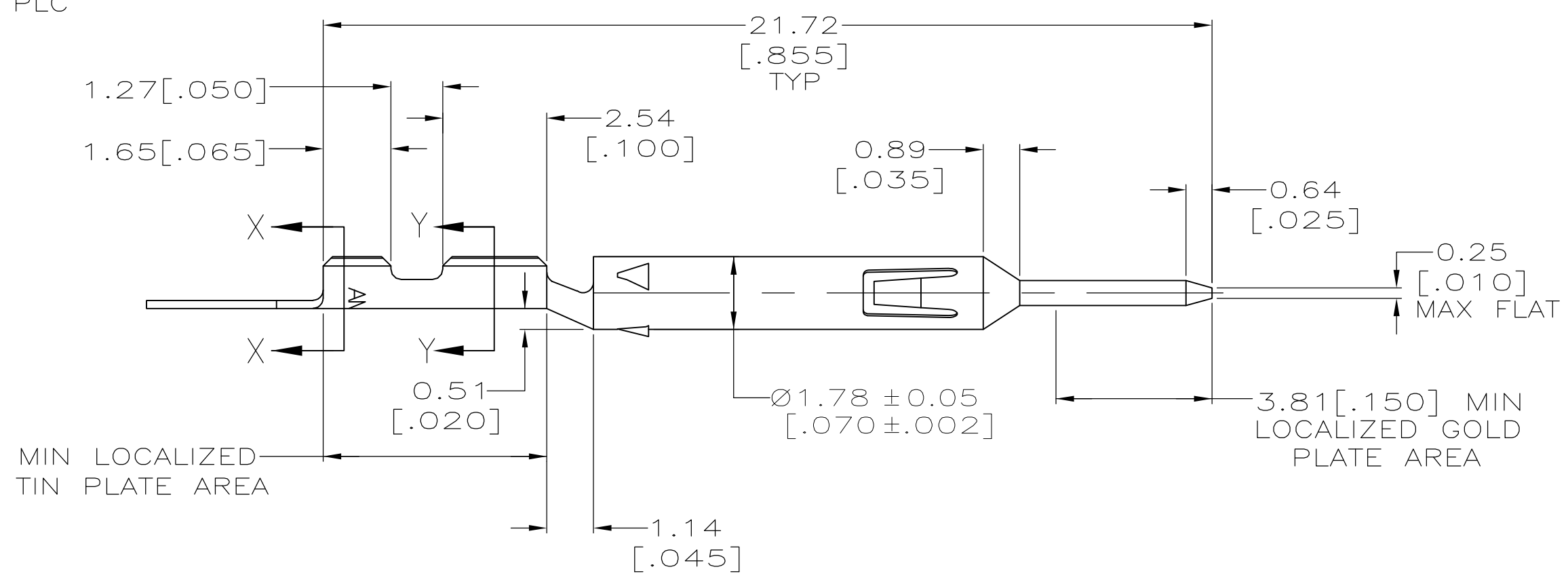

SECTION X-X  
 SCALE 15:1

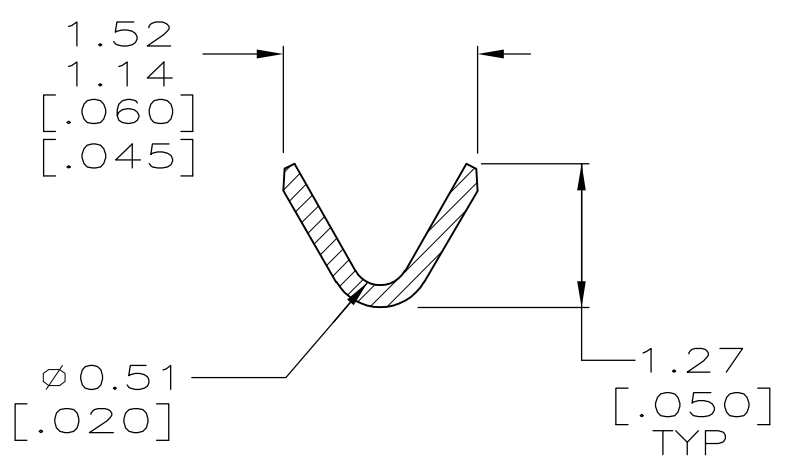

SECTION Y-Y  
 SCALE 15:1

|  |                  |                                 |   |                 |
|--|------------------|---------------------------------|---|-----------------|
| THIS DRAWING IS A CONTROLLED DOCUMENT. |                  | DWN G. ATTADIA - DOCK5 11-11-04 | 1 5787113-3   |                 |
| DIMENSIONS: mm [INCHES]                |                  | CHK J. GERACE 11-11-04          | FINISH  |                 |
| TOLERANCES UNLESS OTHERWISE SPECIFIED: |                  | APVD M. WALMSLEY 11-11-04       | PART NUMBER   |                 |
| 0 PLC ± -                              | 1 PLC ± -        | PRODUCT SPEC                    | Tyco Electronics Corporation<br>Harrisburg, PA 17105-3608 |                 |
| 2 PLC ± 0.13 [.005]                    | 3 PLC ± -        | APPLICATION SPEC                | NAME PIN CONTACT, SPECIAL, AMPLIMITE                      |                 |
| 4 PLC ± -                              | ANGLES ± 2°      | WEIGHT -                        | SIZE A2   | CAGE CODE 00779 |
| MATERIAL 3                             | FINISH SEE TABLE | CUSTOMER DRAWING                | DRAWING NO C=5787113                                      | RESTRICTED TO - |
|  |                  |                                 | SCALE 8:1   | SHEET 1 of 1    |
|  |                  |                                 | REV A   |                 |