

PART NUMBER	ITEM ① BODY	ITEM ② CONTACT	ITEM ③ INTERFACE	ITEM ④ INSULATOR	ITEM ⑤ INSULATOR	ITEM ⑥ CRIMP SLEEVE	ITEM ⑦ END CAP
133-9404-101	COPPER ALLOY GOLD PL .00005 MIN OVER COPPER PL .00005 MIN	COPPER ALLOY GOLD PL .00005 MIN OVER COPPER PL .00005 MIN	BERYLLIUM COPPER GOLD PL .00005 MIN OVER COPPER PL .00005 MIN	TEFLON	TEFLON	COPPER ALLOY GOLD PL .00005 MIN OVER COPPER PL .00005 MIN	COPPER ALLOY GOLD PL .00005 MIN OVER COPPER PL .00005 MIN
133-9404-104	COPPER ALLOY SILVER PL .00005 MIN OVER COPPER PL .00005 MIN	COPPER ALLOY SILVER PL .00005 MIN OVER COPPER PL .00005 MIN	BERYLLIUM COPPER SILVER PL .00005 MIN OVER COPPER PL .00005 MIN	TEFLON	TEFLON	COPPER ALLOY SILVER PL .00005 MIN OVER COPPER PL .00005 MIN	COPPER ALLOY SILVER PL .00005 MIN OVER COPPER PL .00005 MIN

DRAWING NO. C - 133-9404-101/110	
0	REVISIONS
ENGINEERING RELEASE	
1	7-21-03 R H T R J B ECN 48905
COPPER ALLOY WAS COPPER COPPER ALLOY WAS BRASS VERSION UPDATE	
2	1-12-07 P A J T S A K 2-8-07 ECN 50903
VERSION UPDATE	
***** * REVISION NUMBER FOLLOWED BY AN ALPHA * * CHARACTER INDICATES DRAWING CLARIFI- * * CATION OR PART NUMBER ADDITION ONLY. * *****	
2a	1-22-09 P A J M R J C N 1-27-09 ECN 51748

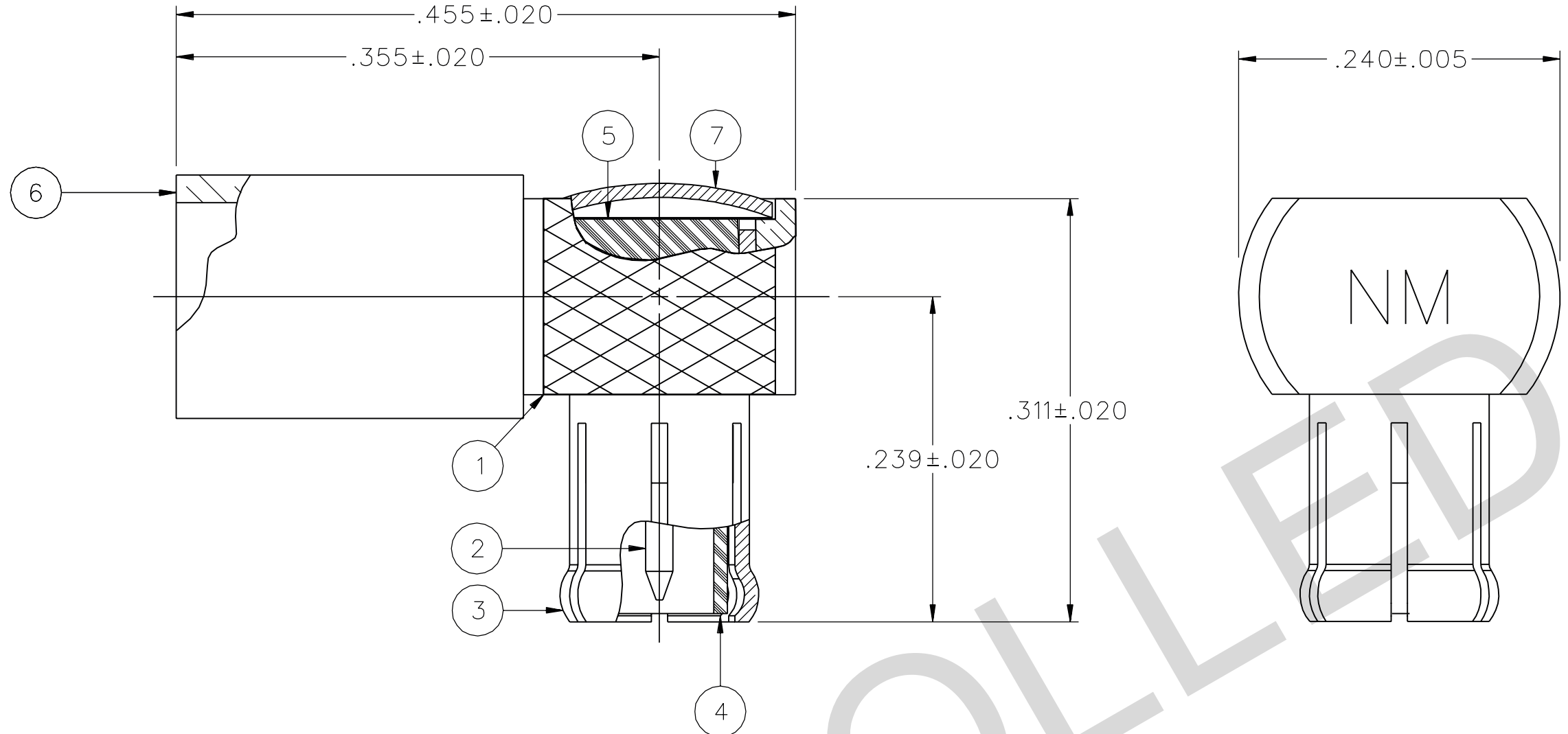

NOTES:

1. SPECIFICATIONS:

IMPEDANCE: 50 OHMS
 FREQUENCY RANGE: 0-6 GHz
 VSWR: 1.07+.04F MAX (F IN GHz)
 WORKING VOLTAGE: 335 VRMS MAX AT SEA LEVEL
 DIELECTRIC WITHSTANDING VOLTAGE: 1000 VRMS MIN AT SEA LEVEL
 INSULATION RESISTANCE: 10000 MEGOHM MIN
 CONTACT RESISTANCE:
 CENTER CONTACT - INITIAL 5 MILLIOHM MAX, AFTER ENVIRONMENTAL 15 MILLIOHM MAX
 OUTER CONDUCTOR - INITIAL 1 MILLIOHM MAX, AFTER ENVIRONMENTAL 1.5 MILLIOHM MAX
 BODY TO CABLE - INITIAL 1 MILLIOHM MAX, AFTER ENVIRONMENTAL NOT APPLICABLE
 CORONA LEVEL: 250 VOLTS MINIMUM AT 70,000 FEET
 INSERTION LOSS: .2 DB MAX AT 1GHz
 RF LEAKAGE: -55 DB AT 2.5 GHz
 RF HIGH POTENTIAL WITHSTANDING VOLTAGE: 700 VRMS AT 4 AND 7 MHz

MECHANICAL:

ENGAGE/DISENGAGE FORCE: 5.6 LBS MAX ENGAGEMENT
 1.0/8.0 LBS MIN/MAX DISENGAGEMENT
 CONTACT RETENTION FORCE: 2.3 LBS MIN AXIAL FORCE
 CONTACT RETENTION TORQUE: NOT APPLICABLE
 COUPLING MECHANISM RETENTION: NOT APPLICABLE
 CABLE ACCEPTABILITY: RG 188 DOUBLE SHIELDED, RG 316 DOUBLE SHIELDED
 CABLE HEX CRIMP SIZE: .151
 CABLE RETENTION: 25 LBS MIN AXIAL FORCE
 DURABILITY: 500 CYCLES MIN

ENVIRONMENTAL:

(MEETS OR EXCEEDS THE APPLICABLE PARAGRAPH OF MIL-PRF-39012)
 THERMAL SHOCK: MIL-STD-202, METHOD 107, CONDITION F
 OPERATING TEMPERATURE: -65 DEG C TO 165 DEG C
 CORROSION: MIL-STD-202, METHOD 101, CONDITION B
 SHOCK: MIL-STD-202, METHOD 213, CONDITION B
 VIBRATION: MIL-STD-202, METHOD 204, CONDITION B
 MOISTURE RESISTANCE: MIL-STD-202, METHOD 106

2. CONNECTOR MARKED "NM" FOR NON-MAGNETIC.

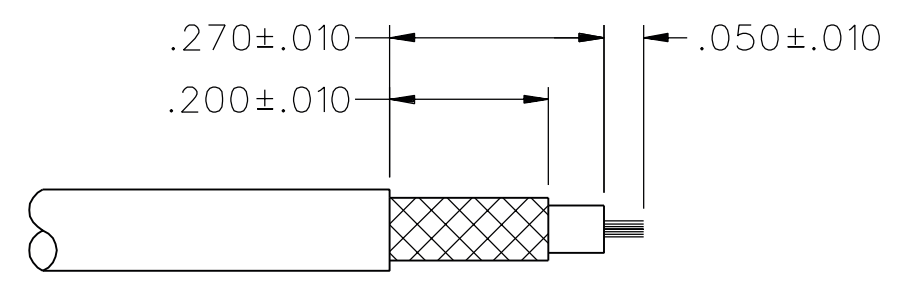

CABLE STRIP DIMENSIONS

4:1

CUSTOMER DRAWING

THIS DRAWING TO BE INTERPRETED PER ASME Y 14.5M - 1994

"μ STATION"

COMPANY CONFIDENTIAL

TOLERANCE UNLESS OTHERWISE SPECIFIED	DRAWN BY RSH	DATE 3-6-03	
DECIMALS mm	CHECKED BY TAK	DATE 7-25-03	
.XX _____	APPROVED BY RJB	DATE 7-25-03	TITLE PLUG ASSEMBLY RIGHT ANGLE, NON-MAGNETIC MCX, RG 316 DS
.XXX _____	RELEASE DATE 7-25-03	SCALE 10:1	SHEET 2 OF 2
MATL _____	U/M INCH		DRAWING NO. C - 133-9404-101/110
FINISH _____			