

NOTES:

SPECIFICATIONS;
 Impedance: 50 OHMS
 Frequency Range: 0-10 GHz
 VSWR: 0-7 GHz, 1.5 MAX.
 Working Voltage: 1000 V rms @ Sea Level
 Insulation Resistance: 5k M Ohms min.

ALL DIMENSIONS ARE FOR REFERENCE ONLY

NO.	DESCRIPTION	QTY	MATERIAL	FINISH
1	BODY	1	BRASS	NICKEL
2	PIN 1	1	BRASS	GOLD
3	PIN 2	1	BRASS	GOLD
4	INSULATION	2	TEFLON	NONE
5	SLEEVE	1	BRASS	NICKEL
6	CHASSIS	1	BRASS	NICKEL
7	SHELL	1	BRASS	NICKEL
8	RETAINING RING	1	BRASS	NICKEL
9	GASKET	1	SI-RUBBER	ORANGE

REVISIONS					
ZONE	REV.	DESCRIPTION	DATE	DRAWN BY	ECR NUMBER
ALL	A	INITIAL DRAWING RELEASE	8/22/2012	PFR	N/A

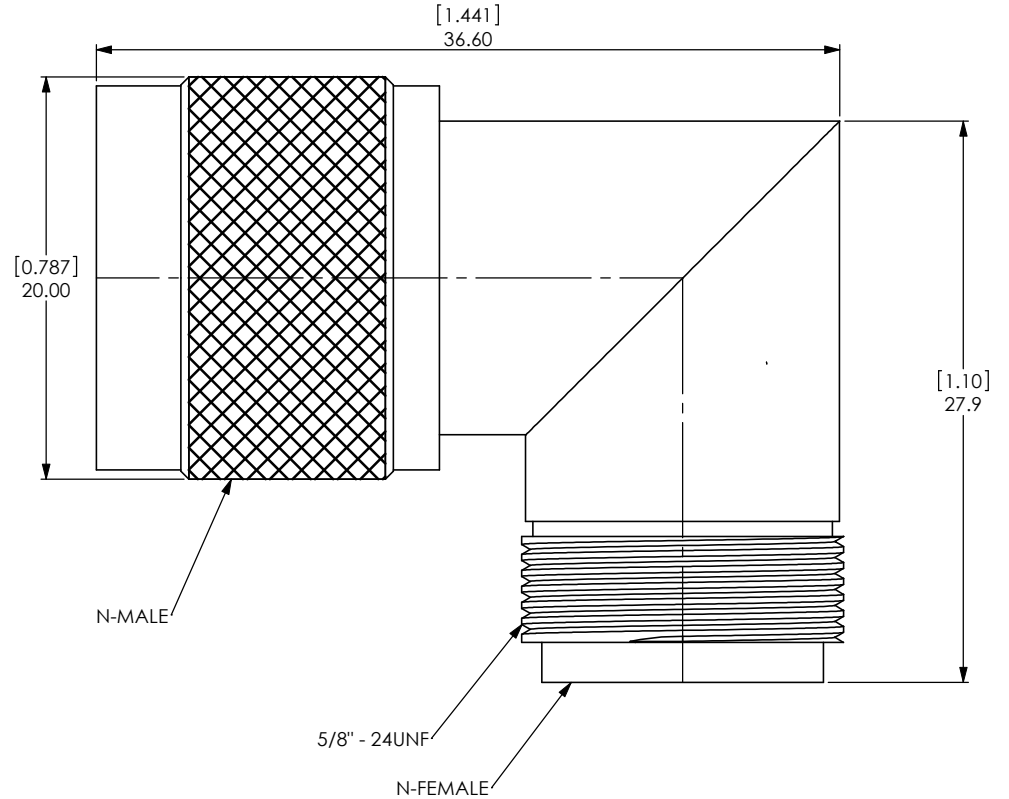

Notes:

THE COMPONENT(S), INCLUDING ANY PLATING, FINISHES, COATINGS, CHEMICALS AND SURFACES TREATMENTS, SUPPLIED IN THIS DOCUMENT/DRAWING MUST CONFORM AND COMPLY WITH THE LATEST ISSUE OF LAIRD TECHNOLOGIES SPECIFICATION LT-GES-001, WHICH FULLY INCLUDES BUT IS NOT LIMITED TO ALL CONTENTS OF EU DIRECTIVES 2002/96/EC (RoHS DIRECTIVE), AS WELL AS INCLUDES REQUIREMENTS OF THE JOINT INDUSTRY GUIDE STANDARD JIG-101, APRIL 2005. THE COMPONENT(S) IN THIS DOCUMENT/DRAWING MAY BE SUBJECT TO A FULL COMPOUND ANALYSIS FOR PROOF OF COMPLIANCE. THE LATEST ISSUE OF LAIRD TECHNOLOGIES SPECIFICATION LT-GES-001, (GENERAL SPECIFICATION FOR THE ENVIRONMENT) IS READILY AVAILABLE UPON REQUEST FROM THE SUPPLIER.

UNLESS OTHERWISE NOTED, THIS DOCUMENT CONTAINS LAIRD TECHNOLOGIES CONFIDENTIAL INFORMATION. REPRODUCTION, USE, DISCLOSURE OR TRANSMITTAL OF ALL OR ANY PART OF THIS DOCUMENT IS PROHIBITED EXCEPT TO THE EXTENT APPROVED IN WRITING BY AN AUTHORIZED REPRESENTATIVE OF LAIRD TECHNOLOGIES. LAIRD TECHNOLOGIES RESERVES ALL RIGHTS UNDER PATENTS, TRADEMARKS, COPYRIGHTS AND TRADE SECRETS. COPYRIGHT, LAIRD TECHNOLOGIES 2008, ALL RIGHTS RESERVED.

MATERIAL: See Table

FINISH: See Table

APPROVALS **DATE**

ME: _____

RF: _____

EM: _____

Prod: _____

THIRD ANGLE PROJECTION

INTERPRET DIMENSIONING AND TOLERANCING IN ACCORDANCE WITH ASME Y14.5M-1994

DO NOT SCALE DRAWING
 TOLERANCES UNLESS OTHERWISE SPECIFIED

DIMENSIONS ARE IN MILLIMETERS

ANGLE: ±30'
 0 PLACE DECIMAL: ±0.5
 1 PLACE DECIMAL: ±0.25
 2 PLACE DECIMAL: ±0.13

Laird TECHNOLOGIES 1751 WILKENING COURT
 SCHAUMBURG, IL 60173
 USA

TITLE: N-Female to N-Male Right Angle

SIZE DWG NO. A3 CNFMRA **REV** A

WEIGHT: **PREVIOUS#** **SCALE:** **SHEET 1 OF 1**