

High-Voltage, Step-Down DC-DC Controllers in μ MAX

MAX1744/MAX1745

General Description

The MAX1744/MAX1745 are step-down DC-DC controllers capable of handling up to 36V inputs. These parts use a proprietary current-limited control scheme for excellent light- and full-load efficiency, while their 330kHz (max) switching frequency permits small external components for space-critical applications. Operation to 100% duty cycle permits the lowest possible dropout voltage.

The MAX1744 contains an internal feedback network that provides a pin-selectable output voltage of either 3.3V or 5V. The MAX1745 uses an external feedback network to generate an adjustable output voltage between 1.25V and 18V.

The MAX1744/MAX1745 are available in a space-saving 10-pin μ MAX[®] package.

Applications

- Automotive Electronics
- Telecom Systems
- Wall-Cube-Powered Devices
- Industrial Control Systems
- Firewire[®]/IEEE[®] 1394

μ MAX is a registered trademark of Maxim Integrated Products, Inc.

Firewire is a registered trademark of Apple, Inc.

IEEE is a registered service mark of the Institute of Electrical and Electronics Engineers, Inc.

Features

- High-Voltage Operation (Up to 36V IN)
- Efficiency > 90%
- Output Power Capability Exceeds 50W
- 10-Pin μ Max Package
- Low-Dropout Voltage
- 100% (max) Duty Cycle
- 90 μ A Quiescent Current
- 4 μ A Shutdown Current
- Up to 330kHz Switching Frequency
- Output Voltage
 - 5V or 3.3V (MAX1744)
 - Adjustable 1.25V to 18V (MAX1745)
- Current-Limited Control Scheme

Ordering Information

PART	TEMP RANGE	PIN-PACKAGE
MAX1744EUB+	-40°C to +85°C	10 μ MAX
MAX1744AUB+	-40°C to +125°C	10 μ MAX
MAX1744EUB/V+	-40°C to +85°C	10 μ MAX
MAX1745EUB+	-40°C to +85°C	10 μ MAX
MAX1745AUB+	-40°C to +125°C	10 μ MAX
MAX1745EUB/V+	-40°C to +85°C	10 μ MAX

+Denotes a lead(Pb)-free/RoHS-compliant package.

/V Denotes an automotive qualified part.

Typical Operating Circuit

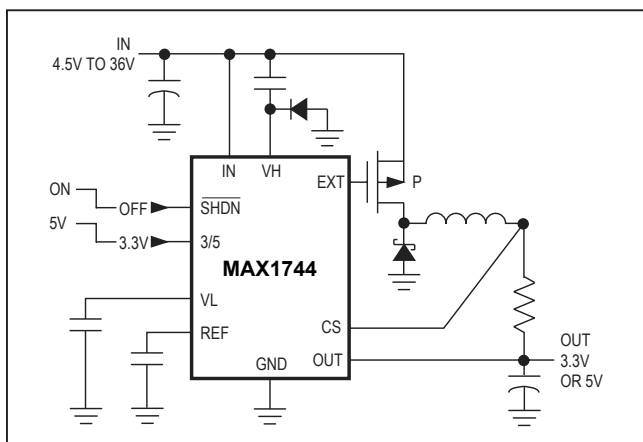

Pin Configuration

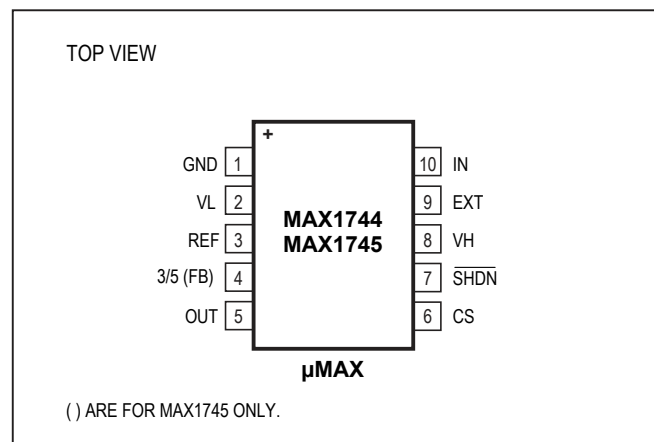

19-1776; Rev 5; 11/22

Absolute Maximum Ratings

IN, EXT, $\overline{\text{SHDN}}$ to GND.....	-0.3V to +38V
VH to GND	-0.3V to +34V
VH, EXT to IN.....	-7V to +0.3V
CS, OUT to GND.....	-0.3V to +20V
FB, 3/5, REF to GND	-0.3V to (VL + 0.3V)
VL to GND	-0.3V to 6V
Continuous Power Dissipation ($T_A = +70^\circ\text{C}$)	
10-Pin μ MAX (derate 5.6mW/ $^\circ\text{C}$ above 70 $^\circ\text{C}$)	444mW

Operating Temperature Range	
MAX174_EUB.....	-40 $^\circ\text{C}$ to +85 $^\circ\text{C}$
MAX174_AUB.....	-40 $^\circ\text{C}$ to +125 $^\circ\text{C}$
Junction Temperature.....	+150 $^\circ\text{C}$
Storage Temperature Range	-65 $^\circ\text{C}$ to +150 $^\circ\text{C}$
Lead Temperature (soldering, 10s)	+300 $^\circ\text{C}$

Stresses beyond those listed under "Absolute Maximum Ratings" may cause permanent damage to the device. These are stress ratings only, and functional operation of the device at these or any other conditions beyond those indicated in the operational sections of the specifications is not implied. Exposure to absolute maximum rating conditions for extended periods may affect device reliability.

Package Information

10 μ MAX

Package Code	U10CN+1
Outline Number	21-0061
Land Pattern Number	90-0330
Thermal Resistance, Four-Layer Board:	
Junction to Ambient (θ_{JA})	116 $^\circ\text{C}/\text{W}$
Junction to Case (θ_{JC})	43.6 $^\circ\text{C}/\text{W}$

For the latest package outline information and land patterns (footprints), go to www.maximintegrated.com/packages. Note that a "+", "#", or "-" in the package code indicates RoHS status only. Package drawings may show a different suffix character, but the drawing pertains to the package regardless of RoHS status.

Package thermal resistances were obtained using the method described in JEDEC specification JESD51-7, using a four-layer board. For detailed information on package thermal considerations, refer to www.maximintegrated.com/thermal-tutorial.

Electrical Characteristics

($V_{IN} = V_{\overline{SHDN}} = 5.5V$ to $36V$, $3/5 = GND$, $I_{LOAD} = 0$, $T_A = 0^{\circ}C$ to $+85^{\circ}C$, unless otherwise noted. Typical values at $V_{IN} = V_{\overline{SHDN}} = 36V$, $T_A = +25^{\circ}C$.)

PARAMETER	CONDITIONS	MIN	TYP	MAX	UNITS
Input Voltage Range		4.5		36	V
Supply Current into IN	$V_{\overline{SHDN}} = V_{IN} = 5.5V$ to $36V$		90	140	μA
Shutdown Supply Current	$\overline{SHDN} = GND$		4	12	μA
Output Voltage (MAX1744)	$3/5 = VL$	4.85	5.00	5.15	V
	$3/5 = GND$	3.20	3.30	3.40	
OUT Input Current (MAX1744)	$3/5 = VL$, $V_{OUT} = 5V$		28	44	μA
FB Threshold Voltage (MAX1745)	Falling edge, hysteresis = 8mV	1.22	1.25	1.28	V
FB Input Current (MAX1745)		-50		50	nA
VH Output Voltage with Respect to IN	$V_{IN} = 5.5V$ to $36V$, $I_{VH} = 100\mu A$ to $20mA$	-6.0	-5.3	-4.3	V
VL Output Voltage	$V_{IN} = 5.5V$ to $36V$, $I_{VL} = 100\mu A$ to $2mA$	4.5	5.0	5.5	V
VL Undervoltage Lockout		2.0	3.0	4.1	V
CS Threshold Voltage	$V_{CS} = V_{OUT} = 2.5V$ to $18V$	85	100	115	mV
	$V_{CS} = V_{OUT} = V_{GND}$	80	110	150	
CS Input Current	$V_{CS} = V_{OUT} = 2.5V$ to $18V$	0	15	25	μA
	$V_{CS} = V_{OUT} = V_{GND}$	-25		0	
\overline{SHDN} , 3/5 Logic-High Threshold	$V_{IN} = 4.5V$ to $36V$	2.4			V
\overline{SHDN} , 3/5 Logic-Low Threshold	$V_{IN} = 4.5V$ to $36V$			0.4	V
3/5 Input Current	$\overline{SHDN} = GND$			± 1	μA
\overline{SHDN} Input Current	$3/5 = GND$			± 1	μA
	$V_{\overline{SHDN}} = 36V$			12	
EXT Resistance			8	20	Ω
Minimum EXT Off-Time		1.5	2.0	2.5	μs
Minimum EXT On-Time		0.7	1.0	1.5	μs
Output Line Regulation	Figure 1, $5.5V < V_{IN} < 36V$, $I_{LOAD} = 1A$		5		mV/V
Output Load Regulation	Figure 1, $V_{IN} = 12V$, $30mA < I_{LOAD} < 2A$		15		mV/A
Reference Voltage	$I_{REF} = 0$	1.22	1.25	1.28	V
REF Load Regulation	$0 \leq I_{REF} \leq 100\mu A$		4	10	mV
REF Line Regulation	$V_{IN} = 4.5V$ to $36V$, $I_{REF} = 0$		30	60	$\mu V/V$

Electrical Characteristics

(V_{IN} = V_{SHDN} = 5.5V to 36V, 3/5 = GND, I_{LOAD} = 0, T_A = -40°C to +85°C, unless otherwise noted.) (Note 1)

PARAMETER	CONDITIONS	MIN	TYP	MAX	UNITS
Input Voltage Range		4.5		36	V
Supply Current into IN	V _{SHDN} = V _{IN} = 5.5V to 36V			140	μ A
Shutdown Supply Current	$\overline{\text{SHDN}}$ = GND			12	μ A
Output Voltage (MAX1744)	3/5 = VL	4.85		5.15	V
	3/5 = GND	3.20		3.40	
OUT Input Current (MAX1744)	3/5 = VL, V _{OUT} = 5V			44	μ A
FB Threshold Voltage (MAX1745)	Falling edge, hysteresis = 8mV	1.22		1.28	V
FB Input Current (MAX1745)		-50		50	nA
VH Output Voltage with Respect to IN	V _{IN} = 5.5V to 36V, I _{VH} = 100 μ A to 20mA	-6.0V		-4.3V	V
VL Output Voltage	V _{IN} = 5.5V to 36V, I _{VL} = 100 μ A to 2mA	4.5		5.5	V
VL Undervoltage Lockout		2.0		4.1	V
CS Threshold Voltage	V _{CS} = V _{OUT} = 2.5V to 18V	85		115	mV
	V _{CS} = V _{OUT} = V _{GND}	80		150	
CS Input Current	V _{CS} = V _{OUT} = 2.5V to 18V	0		25	μ A
	V _{CS} = V _{OUT} = V _{GND}	-25		0	
$\overline{\text{SHDN}}$, 3/5 Logic-High Threshold	V _{IN} = 4.5V to 36V	2.4			V
$\overline{\text{SHDN}}$, 3/5 Logic-Low Threshold	V _{IN} = 4.5V to 36V			0.4	V
3/5 Input Current	$\overline{\text{SHDN}}$ = GND			± 1	μ A
$\overline{\text{SHDN}}$ Input Current	3/5 = GND			± 1	μ A
	V _{SHDN} = 36V			12	
EXT Resistance				20	Ω
Minimum EXT Off-Time		1.5		2.5	μ s
Minimum EXT On-Time		0.7		1.5	μ s
Reference Voltage	I _{REF} = 0	1.22		1.28	V
REF Load Regulation	0 \leq I _{REF} \leq 100 μ A			10	mV
REF Line Regulation	V _{IN} = 4.5V to 36V, I _{REF} = 0			60	μ V/V

Electrical Characteristics

(V_{IN} = V_{SHDN} = 5.5V to 36V, 3/5 = GND, I_{LOAD} = 0, T_A = -40°C to +125°C, unless otherwise noted.) (Note 1)

PARAMETER	CONDITIONS	MIN	TYP	MAX	UNITS
Input Voltage Range		4.5		36	V
Supply Current into IN	V _{SHDN} = V _{IN} = 5.5V to 36V			140	μ A
Shutdown Supply Current	$\overline{\text{SHDN}}$ = GND			15	μ A
Output Voltage (MAX1744)	3/5 = VL	4.85		5.15	V
	3/5 = GND	3.20		3.40	
OUT Input Current (MAX1744)	3/5 = VL, V _{OUT} = 5V			44	μ A
FB Threshold Voltage (MAX1745)	Falling edge, hysteresis = 8mV	1.22		1.28	V
FB Input Current (MAX1745)		-50		50	nA
VH Output Voltage with Respect to IN	V _{IN} = 5.5V to 36V, I _{VH} = 100 μ A to 20mA	-6.0V		-4.3V	V
VL Output Voltage	V _{IN} = 5.5V to 36V, I _{VL} = 100 μ A to 2mA	4.5		5.5	V
VL Undervoltage Lockout		1.6		4.1	V
CS Threshold Voltage	V _{CS} = V _{OUT} = 2.5V to 18V	85		115	mV
	V _{CS} = V _{OUT} = V _{GND}	80		150	
CS Input Current	V _{CS} = V _{OUT} = 2.5V to 18V	0		25	μ A
	V _{CS} = V _{OUT} = V _{GND}	-25		0	
$\overline{\text{SHDN}}$, 3/5 Logic-High Threshold	V _{IN} = 4.5V to 36V	2.4			V
$\overline{\text{SHDN}}$, 3/5 Logic-Low Threshold	V _{IN} = 4.5V to 36V			0.4	V
3/5 Input Current	$\overline{\text{SHDN}}$ = GND			± 1	μ A
$\overline{\text{SHDN}}$ Input Current	3/5 = GND			± 1	μ A
	V _{SHDN} = 36V			12	
EXT Resistance				20	Ω
Minimum EXT Off-Time		1.5		2.5	μ s
Minimum EXT On-Time		0.7		1.5	μ s
Reference Voltage	I _{REF} = 0	1.22		1.28	V
REF Load Regulation	0 \leq I _{REF} \leq 100 μ A			10	mV
REF Line Regulation	V _{IN} = 4.5V to 36V, I _{REF} = 0			80	μ V/V

Note 1: Specifications to -40°C are guaranteed by design, not production tested.

Typical Operating Characteristics

(Circuit of Figure 1, $T_A = +25^\circ\text{C}$, unless otherwise specified.)

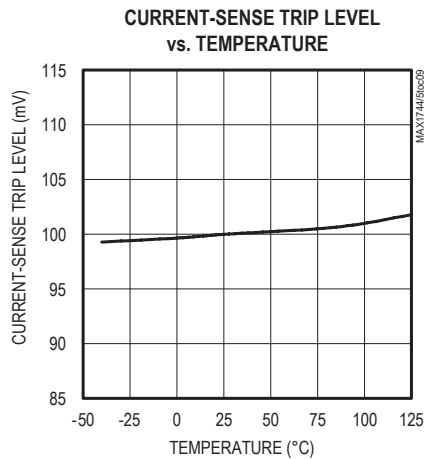
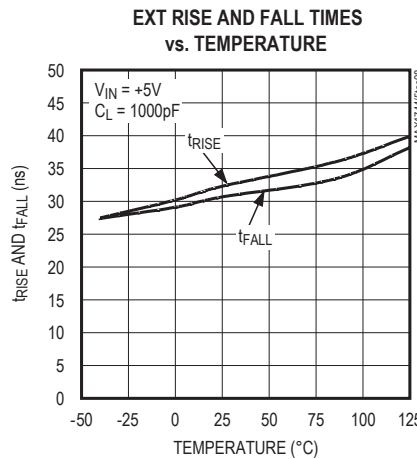
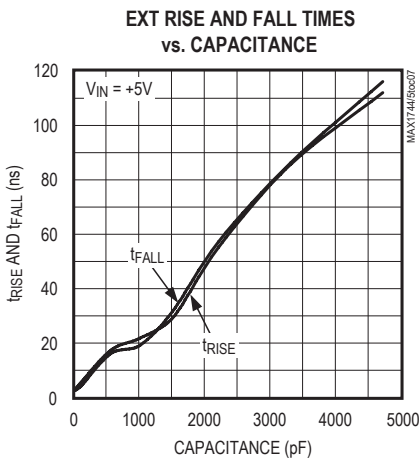
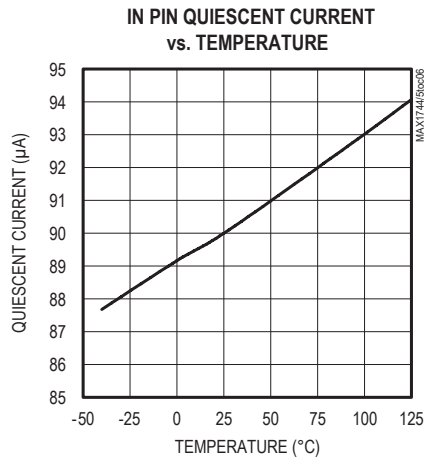
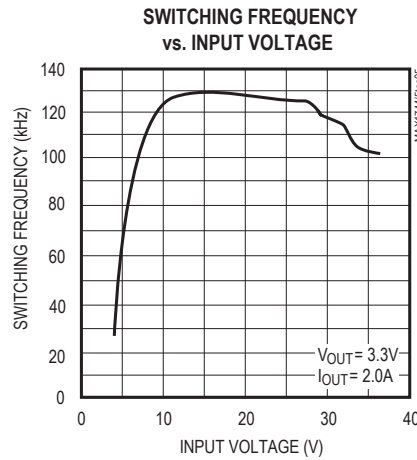
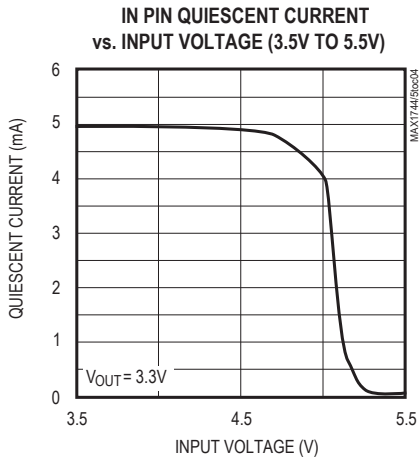
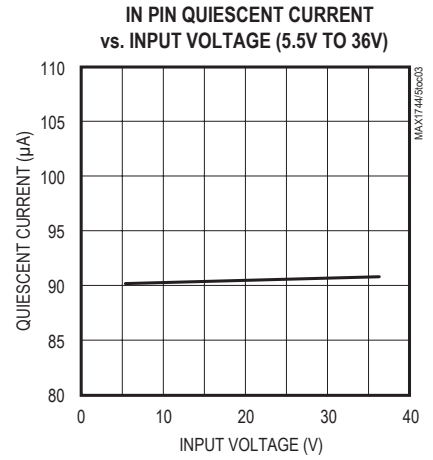
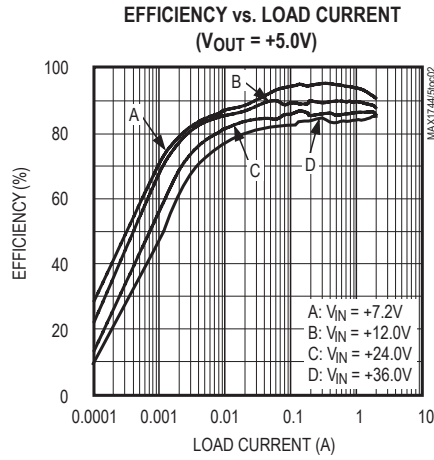
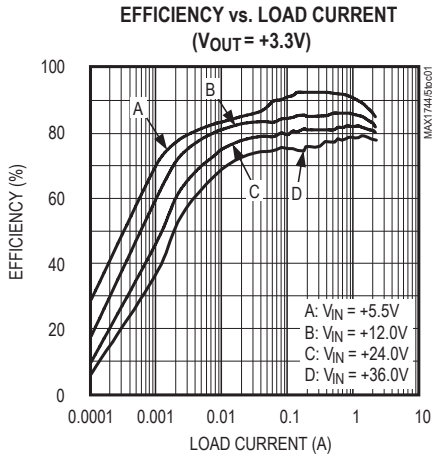

Typical Operating Characteristics (continued)

(Circuit of Figure 1, $T_A = +25^\circ\text{C}$, unless otherwise specified.)

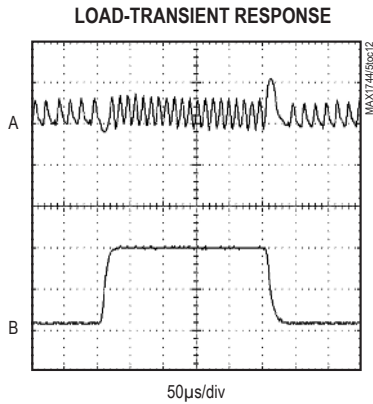
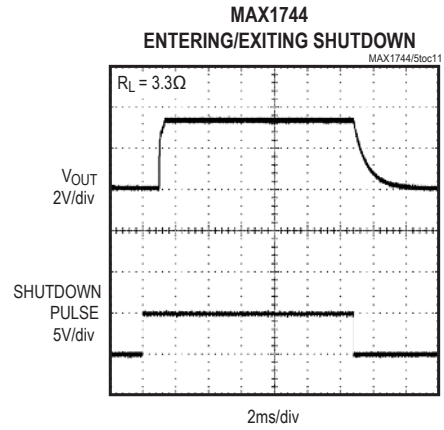
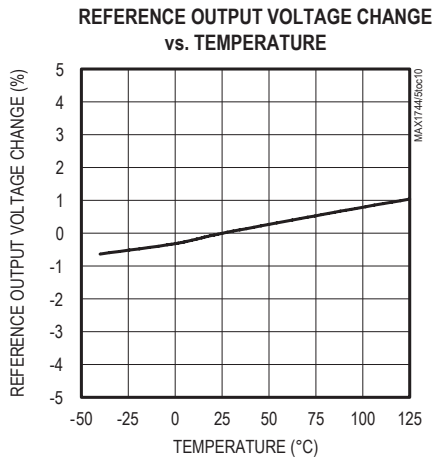

$V_{IN} = 7.2\text{V}$, $V_{OUT} = 3.3\text{V}$, LOAD CURRENT = 0.1A TO 2A
A: V_{OUT} , 50mV/div, 3.3V AC-COUPLED
B: LOAD CURRENT, 1A/div

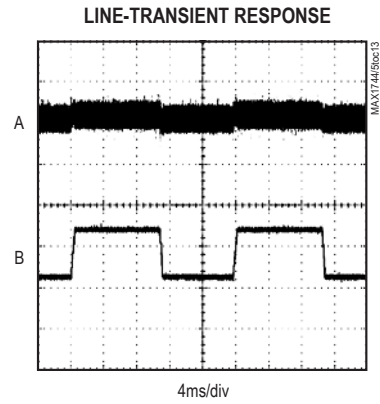

$V_{OUT} = 5\text{V}$, LOAD CURRENT = 1A
A: V_{OUT} , 100mV/div, AC-COUPLED
B: V_{IN} , 6V TO 12V, 5V/div

Pin Description

PIN	NAME		FUNCTION
	MAX1744	MAX1745	
1	GND	GND	Ground
2	VL	VL	5V Linear Regulator Output. VL provides power to the internal circuitry and can supply up to 1mA to an external load. Bypass VL to GND with 4.7 μ F or greater capacitor.
3	REF	REF	1.25V Reference Output. REF can supply up to 100 μ A to an external load. Bypass REF to GND with a 0.1 μ F or greater ceramic capacitor.
4	3/5	—	3.3V or 5V Selection. Connect 3/5 to GND to set the output voltage to 3.3V. Connect 3/5 to VL to set the output voltage to 5V.
4	—	FB	Feedback Input for Adjustable Output Operation. Connect to an external voltage-divider between the output and FB to set the output voltage. The regulation voltage threshold is 1.25V.
5	OUT	OUT	Sense Input for Fixed 5V or 3.3V Output Operation (MAX1744) and Negative Current-Sense Input (MAX1744/5). OUT is connected to an internal voltage-divider (MAX1744). OUT does not supply current.
6	CS	CS	Current-Sense Input. Connect the current-sense resistor between CS and OUT. External MOSFET is turned off when the voltage across the resistor is equal to or greater than the current limit trip level (100mV).
7	$\overline{\text{SHDN}}$	$\overline{\text{SHDN}}$	Active-Low Shutdown Input. Connect $\overline{\text{SHDN}}$ to IN for normal operation. Drive $\overline{\text{SHDN}}$ to low to shut the part off. In shutdown mode, the reference, output, external MOSFET, and internal regulators are turned off.
8	VH	VH	High-Side Linear Regulator Output. VH provides a regulated output voltage that is 5V below IN. The external P-channel MOSFET gate is driven between IN and VH. Bypass VH to IN with a 4.7 μ F or greater capacitor (see the <i>Capacitor Selection</i> section).
9	EXT	EXT	Gate Drive for External P-Channel MOSFET. EXT swings between IN and VH.
10	IN	IN	Positive Supply Input. Bypass IN to GND with a 0.47 μ F or greater ceramic capacitor.

Detailed Description

The MAX1744/MAX1745 are high-voltage step-down DC-DC converter controllers. These devices offer high efficiency over a wide range of input/output voltages and currents, making them optimal for use in applications such as telecom, automotive, and industrial control. Using an external P-channel MOSFET and current-sense resistor allows design flexibility and improved efficiency. The MAX1744/MAX1745 automatically switch from PWM operation at medium and heavy loads to pulse-skipping operation at light loads to improve light-load efficiency. The low 90 μ A quiescent current further optimizes these parts for applications where low input current is critical. Operation to 100% duty cycle allows the lowest possible dropout voltage, which allows a wider input voltage variation. The small size, high switching frequency, and low parts count minimize the required circuit board area and component cost. Figure 1 shows the MAX1744 typical application circuit.

Operating Modes

When delivering low output currents, the MAX1744/MAX1745 operate in discontinuous-conduction mode. Current through the inductor starts at zero, rises as high as the current limit, then ramps down to zero during each cycle (Figure 3). The switch waveform exhibits ringing, which occurs at the resonant frequency of the inductor and stray capacitance, due to residual energy trapped in the core when the commutation diode (D1 in Figure 1) turns off.

When delivering medium-to-high output currents, the MAX1744/MAX1745 operate in PWM continuous-conduction mode (Figure 4). In this mode, current always flows through the inductor and never ramps to zero. The control circuit adjusts the switch duty cycle to maintain regulation without exceeding the peak switching current set by the current-sense resistor.

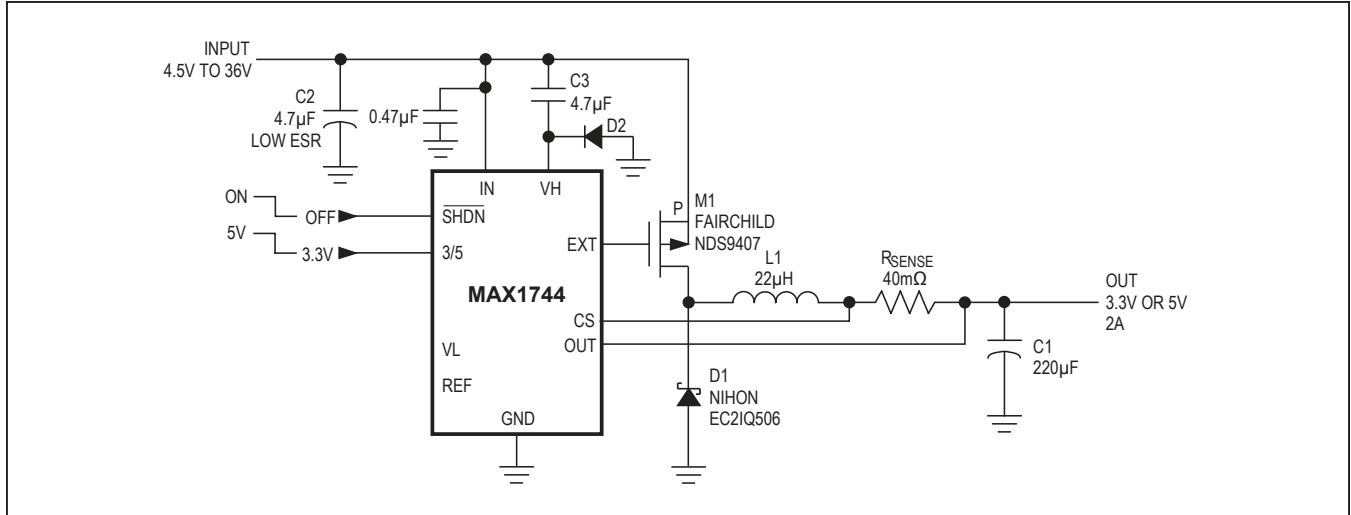

Figure 1. Typical Application Circuit

100% Duty Cycle and Dropout

The MAX1744/MAX1745 operate with a duty cycle up to 100%. This feature extends the input voltage range by turning the MOSFET on continuously when the supply voltage approaches the output voltage. This services the load when conventional switching regulators with less than 100% duty cycle would fail. Dropout voltage is defined as the difference between the input and output voltages when the input is low enough for the output to drop out of regulation. Dropout depends on the MOSFET drain-to-source on-resistance, current-sense resistor, and inductor series resistance, and is proportional to the load current:

$$\text{Dropout voltage} = I_{\text{OUT}} \times [R_{\text{DS(ON)}} + R_{\text{SENSE}} + R_{\text{INDUCTOR}}]$$

Regulation Control Scheme

The MAX1744/MAX1755 have a unique operating scheme that allows PWM operation at medium and high current, with automatic switching to pulse-skipping mode at lower currents to improve light-load efficiency. Figure 2 shows the simplified block diagram.

Under medium- and heavy-load operation, the inductor current is continuous and the part operates in PWM mode. In this mode, the switching frequency is set by either the 1µs minimum on-time or the 2µs minimum off-time, depending on the duty cycle. The duty cycle is approximately the output voltage divided by the input voltage. If the duty cycle is less than 33%, the minimum on-time controls the frequency; and the frequency is approximately $f \approx 1\text{MHz} \times D$, where D is the duty cycle. If the duty

cycle is greater than 33%, the off-time sets the frequency; and the frequency is approximately $f \approx 500\text{kHz} \times (1 - D)$.

In both cases, the voltage is regulated by the error comparator. For low duty cycles (<33%), the MOSFET is turned on for the minimum on-time, causing fixed-on-time operation. During the MOSFET on-time, the output voltage rises. Once the MOSFET is turned off, the voltage drops to the regulation threshold (set by the internal voltage-divider for the MAX1745 and by the external voltage-divider for the MAX1744), at which time another cycle is initiated. For high duty cycles (>33%), the MOSFET remains off for the minimum off-time, causing fixed-off-time operation. In this case, the MOSFET remains on until the output voltage rises to the regulation threshold. Then the MOSFET turns off for the minimum off-time, initiating another cycle.

By switching between fixed-on-time and fixed-off-time operation, the MAX1744/MAX1745 can operate at high input-output ratios, yet still operate up to 100% duty cycle for low dropout. Note that when transitioning from fixed-on-time to fixed-off-time operation, the output voltage drops slightly due to the output ripple voltage. In fixed-on-time operation, the minimum output voltage is regulated, but in fixed-off-time operation, the maximum output voltage is regulated. Thus, as the input voltage drops below approximately three times the output voltage, a decrease in line regulation can be expected. The drop in voltage is approximately $V_{\text{DROP}} \approx V_{\text{RIPPLE}} / 2$.

At light output loads, the inductor current is discontinuous, causing the MAX1744/MAX1745 to operate at lower frequencies, reducing the MOSFET gate drive and switching

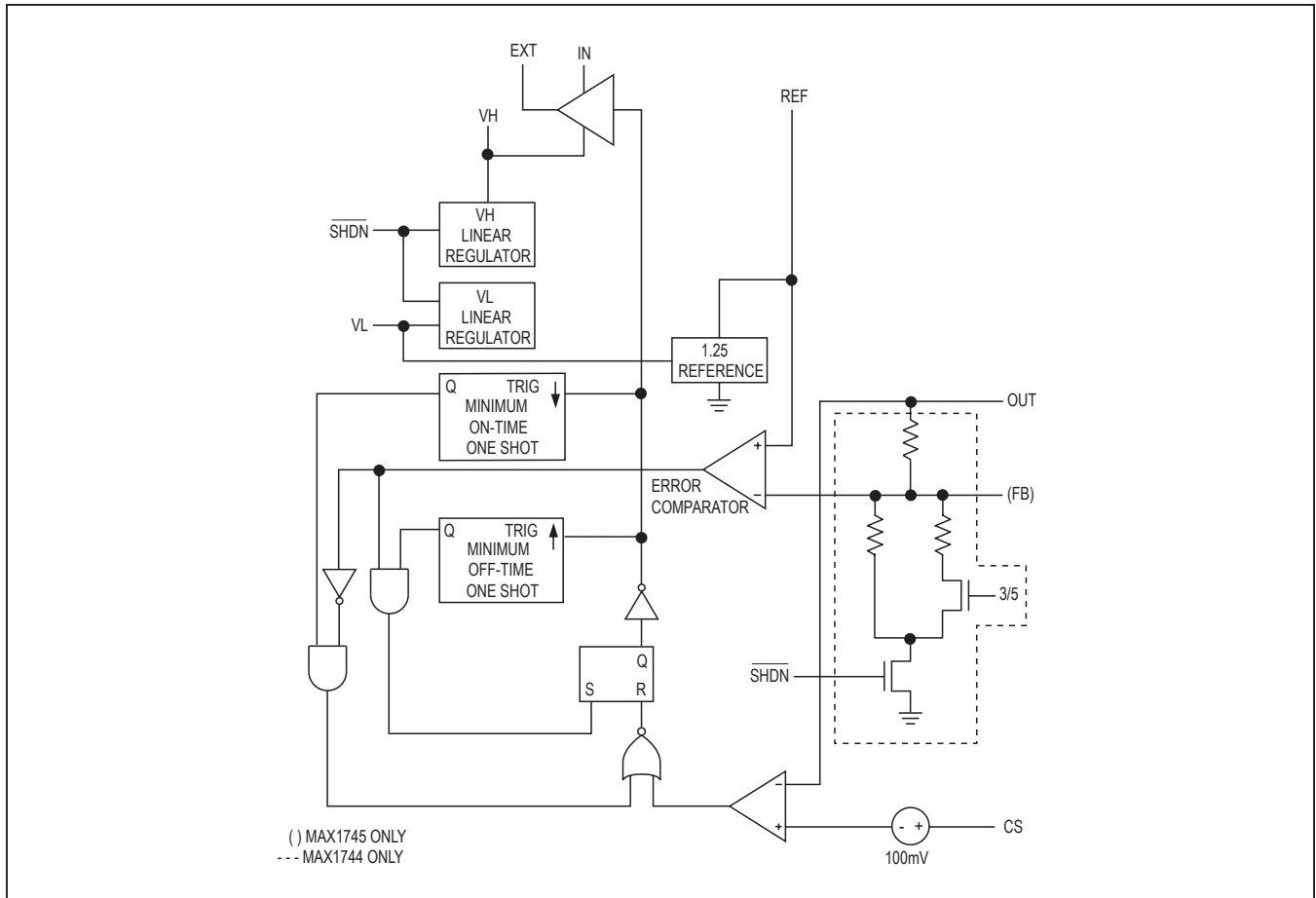

Figure 2. Simplified Functional Diagram

losses. In discontinuous mode, under most circumstances, the on-time will be the fixed minimum on-time of $1\mu\text{s}$. If the inductor value is small, or the current-sense resistor large, the current limit will be tripped before the minimum on-time, terminating the on-time and thus setting the fixed on-time.

If the inductance is too large, or the output capacitance high and equivalent series resistance (ESR) low, then the MOSFET remains on longer than the minimum on-time, until the output capacitor charges beyond the error comparator's $(V_{\text{OUT}} / 1.25\text{V}) \times 8\text{mV}$ hysteresis, causing the part to operate in hysteretic mode. Operating in hysteretic mode results in lower frequency operation. The transition to hysteretic mode occurs at the critical output capacitor ESR:

$$\text{ESR}_{\text{CRITICAL}} = (V_{\text{OUT}} / 1.25\text{V}) \times 8\text{mV} / I_{\text{RIPPLE}}$$

where I_{RIPPLE} is the inductor ripple current, and can be determined by:

$$I_{\text{RIPPLE}} = (V_{\text{IN}} - V_{\text{OUT}}) \times t_{\text{ON(MIN)}} / L$$

where $t_{\text{ON(MIN)}}$ is the minimum on-time ($1\mu\text{s}$) for minimum on-time-control, or:

$$I_{\text{RIPPLE}} = (V_{\text{OUT}}) \times t_{\text{OFF(MIN)}} / L$$

where $t_{\text{OFF(MIN)}}$ is the minimum off-time ($2\mu\text{s}$) for minimum off-time-control.

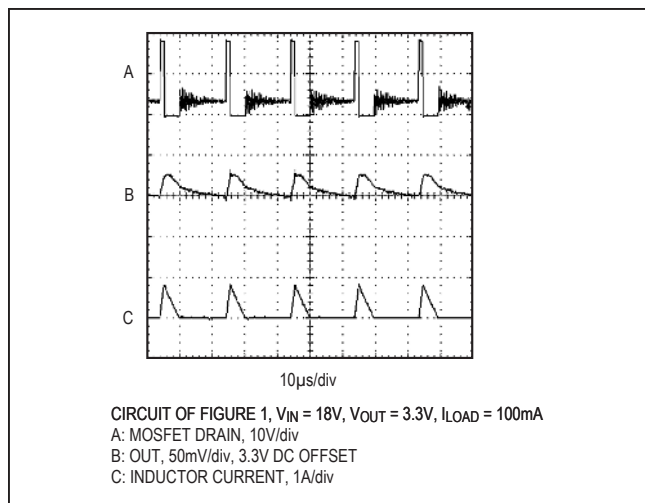

Figure 3. Discontinuous-Conduction Mode, Light-Load-Current Waveform

VL Linear Regulator

The MAX1744/MAX1745 contain a 5V low-side linear regulator (VL) that powers the internal circuit and can supply up to 1mA to an external load. This allows the MAX1744/MAX1745 to operate up to 36V input, while maintaining low quiescent current and high switching frequency. When the input voltage goes below 5.5V, this regulator goes into dropout and the IN pin quiescent current will rise. See the *Typical Operating Characteristics*. Bypass VL with a 4.7 μ F or greater capacitor.

VH Linear Regulator

The MAX1744/MAX1745 contain a high-side linear regulator (VH) that regulates its output to 5V below IN (the positive supply input voltage). This regulator limits the external P-channel MOSFET gate swing (EXT), allowing high input voltage operation without exceeding the MOSFET gate-source breakdown. Bypass VH with a 4.7 μ F or greater capacitor between IN and VH. Fast line transients may drive the voltage on VH negative. The clamp diode (D2) prevents damage to the IC during such a condition. A Schottky diode with a minimum 40V reverse rating such as the Nihon EP05Q04 is sufficient for most applications.

Quiescent Current

The devices' typical quiescent current is 90 μ A. However, actual applications draw additional current to supply MOSFET switching currents, OUT pin current, external feedback resistors (if used), and both the diode and capacitor leakage currents. For example, in the circuit of Figure 1, with IN at 30V and V_{OUT} at 5V, typical no-load supply current for the entire circuit is 100 μ A.

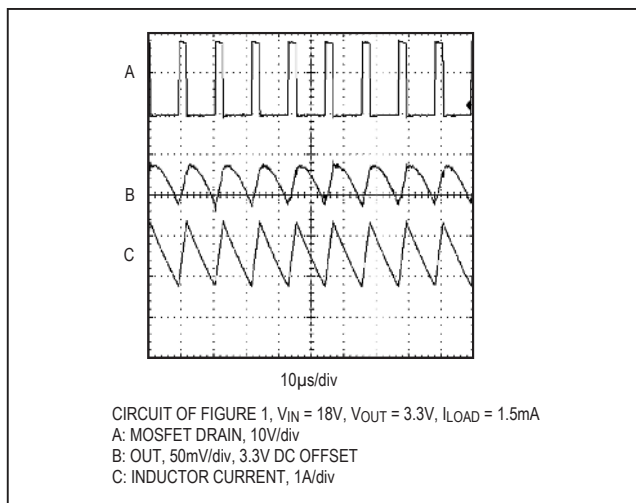

Figure 4. Continuous-Conduction Mode, Heavy-Load-Current Waveform

Shutdown Mode

When \overline{SHDN} is low, the device enters shutdown mode. In this mode, the internal circuitry is turned off. EXT is pulled to IN, turning off the external MOSFET. The shutdown supply current drops to less than 10 μ A. \overline{SHDN} is a logic-level input. Connect \overline{SHDN} to IN for normal operation.

Reference

The 1.25V reference is suitable for driving small external loads. It has a guaranteed 10mV maximum load regulation while sourcing load currents up to 100 μ A. The reference is turned off during shutdown. Bypass the reference with 0.1 μ F for normal operation. Place the bypass capacitor within 0.2in (5mm) of REF, with a direct trace to GND.

Design Information

Setting the Output Voltage

The MAX1744's output voltage can be selected to 3.3V or 5V under logic control by using the 3/5 pin. Connect the 3/5 pin to GND to ensure a 3.3V output, or connect the 3/5 pin to V_L to ensure a 5V output.

The MAX1745's output voltage is set using two resistors, R2 and R3 (Figure 5), which form a voltage-divider between the output and FB. R2 is given by:

$$R2 = R3 \times \left(\frac{V_{OUT}}{V_{REF}} - 1 \right)$$

where $V_{REF} = 1.25V$. Since the input bias current at FB has a maximum value of 50nA, large values (10k Ω to 200k Ω) can be used for R3 with no significant accuracy

loss. For 1% error, the current through R2 should be at least 100 times FB's input bias current.

Current-Sense-Resistor Selection

The current-sense comparator limits the peak switching current to V_{CS}/R_{SENSE} , where R_{SENSE} is the value of the current-sense resistor and V_{CS} is the current-sense threshold. V_{CS} is typically 100mV. Minimizing the peak switching current will increase efficiency and reduce the size and cost of external components. However, since available output current is a function of the peak switching current, the peak current limit must not be set too low.

Set the peak current limit to 1.3 times the maximum load current by setting the current-sense resistor to:

$$R_{CS} = \frac{V_{CS(MIN)}}{1.3 \times I_{OUT(MAX)}}$$

Inductor Selection

The essential parameters for inductor selection are inductance and current rating. The MAX1744/MAX1745 operate with a wide range of inductance values. In many applications, values between 4.7μH and 100μH take best advantage of the controller's high switching frequency.

Calculate the minimum inductance value as follows:

$$L_{(MIN)} = \frac{(V_{IN} - V_{OUT}) \times 1\mu s}{\frac{V_{CS(MIN)}}{R_{CS}}}$$

where 1μs is the minimum on-time. Inductor values between 2 and 10 times $L_{(MIN)}$ are recommended. With high inductor values, the MAX1744/MAX1745 begin continuous-conduction operation at a lower fraction of the full load (see the *Detailed Description* section).

The inductor's saturation and heating current ratings must be greater than the peak switching current to prevent overheating and core saturation. Saturation occurs when the inductor's magnetic flux density reaches the maximum level the core can support, and inductance starts to fall. The heating current rating is the maximum DC current the inductor can sustain without overheating.

For optimum efficiency, the inductor windings' resistance should be less than the current-sense resistance. If necessary, use a toroid, pot-core, or shielded-core inductor to minimize radiated noise. Table 1 lists inductor types and suppliers for various applications.

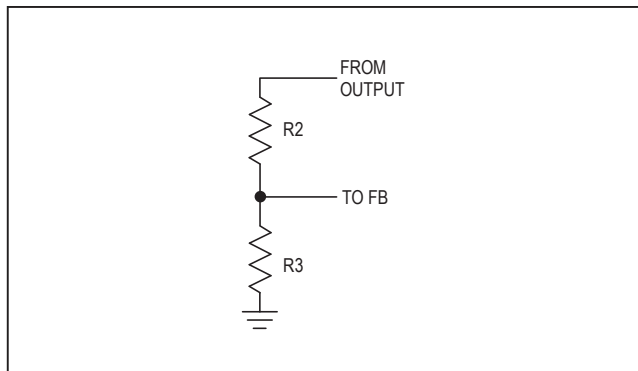

Figure 5. Adjustable-Output Operation Using the MAX1745

External Switching Transistor

The MAX1744/MAX1745 drive a P-channel enhancement-mode MOSFET. The EXT output swings from VH to IN. Be sure that the MOSFET's on-resistance is specified for 5V gate drive or less. Table 1 recommends MOSFET suppliers.

Four important parameters for selecting a P-channel MOSFET are drain-to-source breakdown voltage, current rating, total gate charge (Qg), and $R_{DS(ON)}$. The drain-to-source breakdown voltage rating should be at least a few volts higher than V_{IN} . Choose a MOSFET with a maximum continuous drain-current rating higher than the peak current limit:

$$I_{D(MAX)} \geq I_{LIM(MAX)} = \frac{V_{CS(MAX)}}{R_{SENSE}}$$

The Qg specification should be 80nC or less to ensure fast drain voltage rise and fall times, and reduce power losses during transition through the linear region. Qg specifies all of the capacitances associated with charging the MOSFET gate. EXT pin rise and fall times vary with different capacitive loads, as shown in the *Typical Operating Characteristics*. $R_{DS(ON)}$ should be as low as practical to reduce power losses while the MOSFET is on. It should be equal to or less than the current-sense resistor.

Table 1. Component Suppliers

COMPANY	COUNTRY	PHONE	FAX
AVX	USA	803-946-0690 or 800-282-4975	803-626-3123
Coilcraft	USA	847-639-6400	847-639-1469
Coiltronics	USA	516-241-7876	516-241-9339
Dale/Vishay	USA	402-564-3131	402-563-6418
Kemet	USA	408-986-0424	408-986-1442
International Rectifier	USA	310-322-3331	310-322-3332
IRC	USA	512-992-7900	512-992-3377
Motorola	USA	602-303-5454	602-994-6430
Nichicon	USA Japan	847-843-7500 81-7-5231-8461	847-843-2798 81-7-5256-4158
Nihon	USA Japan	805-867-2555 81-3-3494-7411	805-867-2698 81-3-3494-7414
Sanyo	USA Japan	619-661-6835 81-7-2070-6306	619-661-1055 81-7-2070-1174
Siliconix	USA	408-988-8000 or 800-554-5565	408-970-3950
Sprague	USA	603-224-1961	603-224-1430
Sumida	USA Japan	847-956-0666 81-3-3607-5111	847-956-0702 81-3-3607-5144
United Chemi-Con	USA	714-255-9500	714-255-9400

Diode Selection

The MAX1744/MAX1745's high switching frequency demands a high-speed rectifier. Schottky diodes, such as the 1N5817–1N5822 family or surface-mount equivalents, are recommended. Ultra-high-speed rectifiers with reverse recovery times around 50ns or faster should be used for high output voltages, where the increased forward drop causes less efficiency degradation. Make sure that the diode's peak current rating exceeds the peak current limit set by R_{SENSE} , and that its breakdown voltage exceeds V_{IN} . Schottky diodes are preferred for heavy loads due to their low forward voltage, especially in low-voltage applications. For high-temperature applications, some Schottky diodes may be inadequate due to their high leakage currents. In such cases, ultra-high-speed rectifiers are recommended, although a Schottky diode with a higher reverse voltage rating can often provide acceptable performance.

Capacitor Selection

Choose filter capacitors to service input and output peak currents with acceptable voltage ripple. ESR in the output capacitor is a major contributor to output ripple, so low-ESR capacitors are recommended. Low-ESR tantalum, polymer, or ceramic capacitors are best. Low-ESR aluminum electrolytic capacitors are tolerable, but standard aluminum electrolytic capacitors are not recommended.

Voltage ripple is the sum of contributions from ESR and the capacitor value:

$$V_{RIPPLE} \approx V_{RIPPLE,ESR} + V_{RIPPLE,C}$$

For tantalum capacitors, the ripple is determined by the ESR, but for ceramic capacitors, the ripple is mostly due to the capacitance. Voltage ripple as a consequence of ESR is approximated by:

$$V_{RIPPLE,ESR} \approx (R_{ESR})\Delta I_{p-p}$$

The ripple due to the capacitance is approximately:

$$V_{RIPPLE,C} \approx \frac{LI^2_{PEAK}}{2CV_O}$$

Estimate input and output capacitor values for given voltage ripple as follows:

$$C_{IN} = \frac{\frac{1}{2}LI^2_{\Delta L}}{V_{RIPPLE,CIN}V_{IN}}$$

$$C_{OUT} = \frac{\frac{1}{2}LI^2_{\Delta L}}{V_{RIPPLE,COU}V_{OUT}} \left(\frac{V_{IN}}{V_{IN} - V_{OUT}} \right)$$

where $I_{\Delta L}$ is the change in inductor current.

These equations are suitable for initial capacitor selection; final values should be set by testing a prototype or evaluation kit. When using tantalum capacitors, use good soldering practices to prevent excessive heat from damaging the devices and increasing their ESR. Also, ensure that the tantalum capacitors' surge-current ratings exceed the startup inrush and peak switching currents.

Pursuing output ripple lower than the error comparator's hysteresis (0.6% of the output voltage) is not practical, since the MAX1744/MAX1745 will switch at slower frequencies, increasing inductor ripple current threshold. Choose an output capacitor with a working voltage rating higher than the output voltage.

The input filter capacitor reduces peak currents drawn from the power source and reduces noise and voltage

ripple at IN, caused by the circuit's switching action. Use a low-ESR capacitor. Two smaller-value low-ESR capacitors can be connected in parallel if necessary. Choose input capacitors with working voltage ratings higher than the maximum input voltage.

Place a surface-mount ceramic capacitor very close to IN and GND. This capacitor bypasses the MAX1744/MAX1745, minimizing the effects of spikes and ringing on the power source (IN).

Bypass REF with 0.1 μ F. This capacitor should be placed within 0.2 inches (5mm) of the IC, next to REF, with a direct trace to GND.

Layout Considerations

High-frequency switching regulators are sensitive to PC board layout. Poor layout introduces switching noise into the current and voltage feedback signals and may

degrade performance. The current-sense resistor must be placed within 0.2 inches (5mm) of the controller IC, directly between OUT and CS. Place voltage feedback resistors (MAX1745) next to the FB pin (no more than 0.2in) rather than near the output. Place the 0.47 μ F input bypass capacitor within 0.2in (5mm) of IN.

Refer to the MAX1744 Evaluation Kit manual for a two-layer PC board example.

Chip Information

PROCESS: BiCMOS

Revision History

REVISION NUMBER	REVISION DATE	DESCRIPTION	PAGES CHANGED
0	7/00	Initial release	—
2	8/06	—	—
3	4/09	Added lead-free and automotive qualified packages to <i>Ordering Information</i> .	1–4, 10, 13
4	8/09	Added MAX1744 automotive package to <i>Ordering Information</i> .	1
5	11/22	Moved Package Information after Absolute Maximum Ratings	2, 14



Information furnished by Analog Devices is believed to be accurate and reliable. However, no responsibility is assumed by Analog Devices for its use, nor for any infringements of patents or other rights of third parties that may result from its use. Specifications subject to change without notice. No license is granted by implication or otherwise under any patent or patent rights of Analog Devices. Trademarks and registered trademarks are the property of their respective owners.