

AFCI CONFIDENTIAL

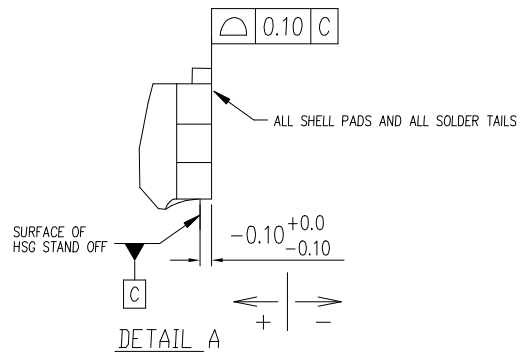
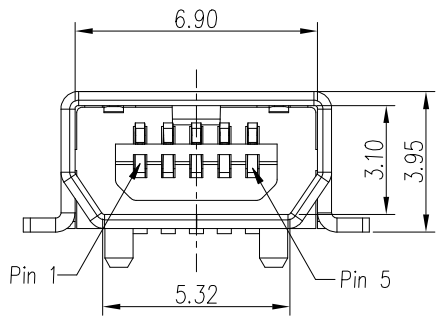
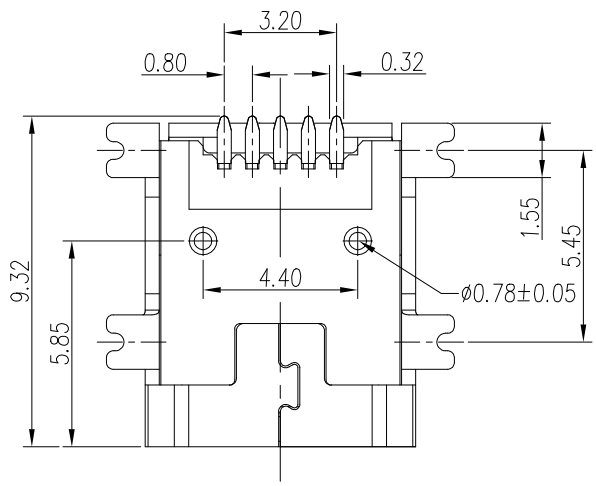
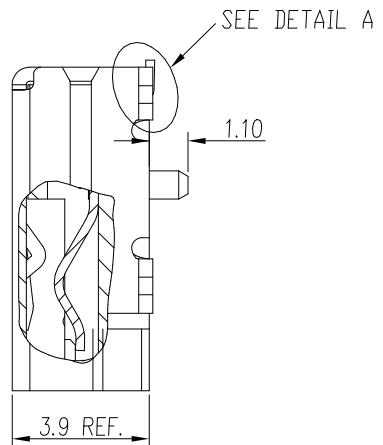
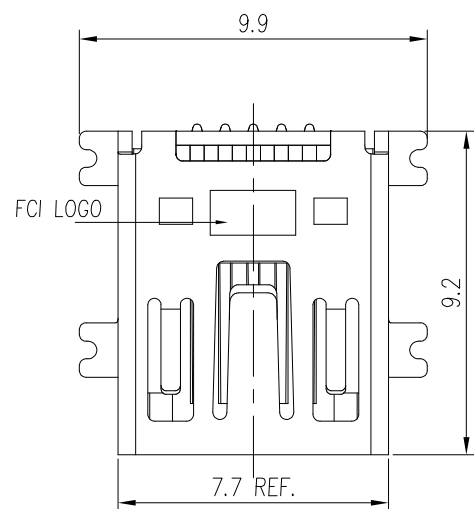

mat'l. code		surface ISO 1302 ✓		tolerance ISO 406 ISO 1101		projection		product family	
ltr		ecn no		dr		date		title	
N		ELX-N-35923-1		YY		01/16/2020		MINI USB AB TYPE RECEPTACLE COONECTOR, R/A SMT TYPE	
								dwg no	
								10033527	
								sheet 1 of 2	
								size	
								A3	
								type	
								Product Customer Drawing	
M		ELX-N-32375		YY		01/08/2019		appd	
								Tim Yao	
								12/30/2019	
sheet		revision		N					
index		sheet		1/2					

This document is the property of and embodies CONFIDENTIAL and PROPRIETARY information of AFCI. No part of the information shown on this document may be used in any way or disclosed to others without the written consent of AFCI.

AFCI CONFIDENTIAL

PROD NO
SEE NOTES

NOTES:

- 1.MATERIAL:
HOUSING: HIGH TEMP THERMOPLASTIC, GLASS FIBER FILLED.
UL 94V-0 RATED, COLOR IN BLACK.
CONTACT: COPPER ALLOY.
SHELL: COPPER ALLOY.
- 2.FINISH:
CONTACT: UNDERPLATED 50u" MIN. NICKEL OVER ALL
100u" MIN. MATTE TIN PLATED IN SOLDERING AREA FOR LEAD FREE VERSION.
SELECTIVE GOLD PLATED IN CONTACT AREA.
SHIELD: N: NICKEL 40u"~120u" PLATED OVERALL.
T: SELECTIVE 60u" MIN. MATTE TIN ON LEGS OVER 40u"~120u" NICKEL.
3. 10033527-X3212XLF: THE HOUSING WILL WITHSTAND EXPOSURE TO 260° PEAK TEMPERATURE FOR 10 SECONDS IN A IR REFLOW APPLICATION. AND THIS PRODCUT MEETS EUROPEAN UNION DIRECTIVES AND OTHER COUNTRY REGULATIONS AS DESCRIBED IN GS-22-008.
4. PRODUCT SPEC: GS-12-174; PACKAGE SPEC: GS-14-873
5. PART NUMBER 10033527N3112LF TO BE EQUAL TO 10033527-T3112LF WITH Ni+Sn PLATING.
PART NUMBER 10033527N3212LF TO BE EQUAL TO 10033527-T3212LF WITH Ni+Sn PLATING.
6. PRODUCT ORDERING DATA :

10033527 - X X X X X LF

SEE NOTE 5 FOR THE SPECIFIC P/N ASSIGNMENT FOR SPECIFIC CUSTOMER

- LF: LEAD FREE PLATING
- M: WITH BROWN MYLAR
- B: WITH BLACK MYLAR
- BLANK: WITHOUT MYLAR
- PACKAGING METHOD:
2: TAPE & REEL PACKAGING.
- POST OPTION:
1 : WITH PLASTIC POST.
- HSG MATERIAL:
1 OR 2: HIGH TEMP THERMOPLASTIC.
- PLATING IN CONTACT AREA:
1 : GOLD FLASH
3 : 30u" Au.
- N: NICKEL FOR SHIELD.
- T: SELECTIVE TIN ON LEGS.

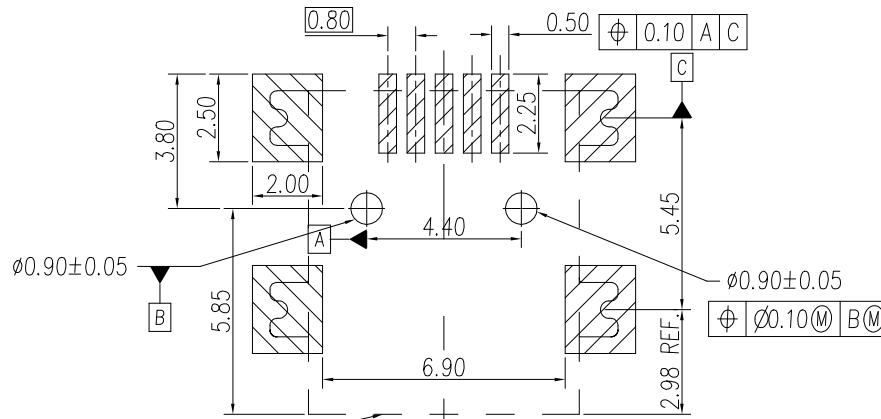

RECOMMENDED PCB LAYOUT
COMPONENT SIDE

BROWN MYLAR SIZE

BLACK MYLAR SIZE

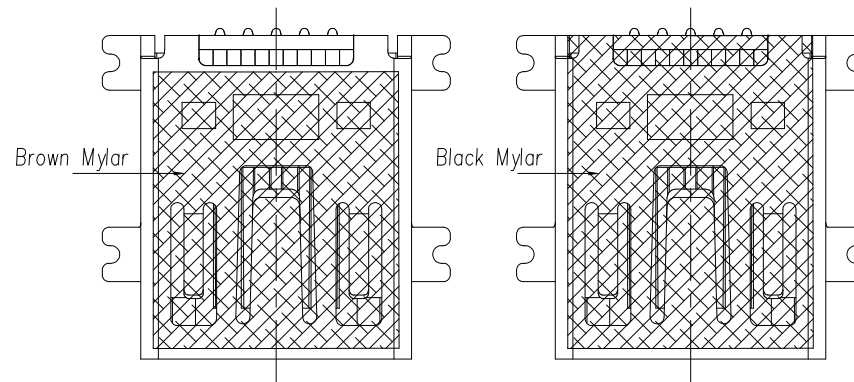

mat'l. code		surface	tolerance	projection	product family
		ISO 1302	ISO 406 ISO 1101		USB 3.0
ltr	ecn no	dr	date	tolerances unless otherwise specified	title
N				angles linear	MINI USB AB TYPE RECEPTACLE COONECTOR, R/A SMT TYPE
				0°±2'	mm
				.0±.30	scale 1:1
				.00±.10	
				.000±.05	
		dr	JASMINE CHAING	9/09/03	dwg no
		eng	Y-Y Bao	01/16/2020	sheet 2 of 2
		chr	Li-Qing Lei	01/16/2020	size
		appd	Tim Yao	01/16/2020	10033527
					A3
					type Product Customer Drawing
sheet index	revision	N			
	sheet	2/2			

This document is the property of and embodies CONFIDENTIAL and PROPRIETARY information of AFCI. No part of the information shown on this document may be used in any way or disclosed to others without the written consent of AFCI.