

# 6-Channel Charge Pump White LED Driver with 16 Dimming Steps and 1-wire Serial Interface



## BD1206GUL

### ●General Description

BD1206GUL is 5ch or 6ch parallel LED driver for the portable instruments.

This IC is equipped with an automatic transition charge pump and 16-step LED drivers. Hence this IC realizes high efficiency and high accuracy drive of LEDs. Additionally, this IC can synchronize LED drive with external PWM signal. This IC is best suited to turn on white LEDs that require high-accuracy LED brightness control.

### ●Features

- 5ch or 6ch parallel LED driver is mounted
- 16-step LED current adjust function
- LED current matching is 5% or less
- Driving control via a single-line digital control interface
- Automatic transition charge pump type DC/DC converter (×1, ×1.5, ×2)
- High efficiency achieved (Maximum over 93%)
- It transits for the most suitable power operating by the LED terminal process of the 6th light when only 5 lights driving
- Various protection functions such as output voltage protection and thermal shutdown circuit are mounted.
- The input external PWM is possible and the back light control interlocked with the motion picture is possible.
- Package: VCSP50L2 (Thick 0.55mm MAX, Pin pitch 0.5mm) CSP15pin package

### ●Typical Application Circuit (6 light with PWM)

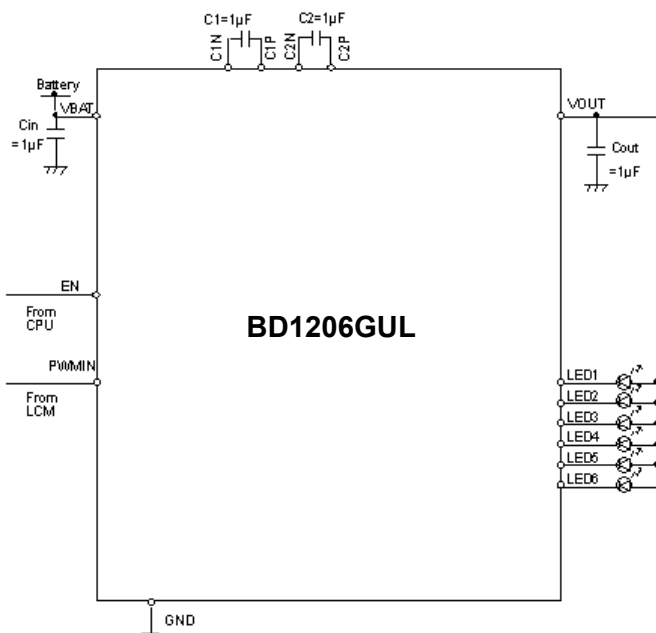

### ●Key Specification

- Operating power supply voltage range: 2.7V to 5.5V
- LED maximum current: 20mA (Typ.)
- Oscillator frequency: 0.85MHz(Typ.)
- Quiescent Current: 0.1µA (Typ.)
- Operating temperature range: -30°C to +85°C

### ●Package

VCSP50L2:

W(Typ.) x D(Typ.) x H(Max.)  
2.00mm x 2.00mm x 0.55mm

### ●Pin Configuration [Bottom View]

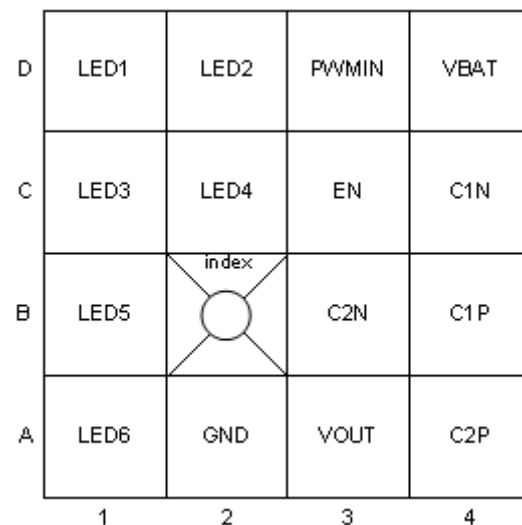

Figure 1. Pin Configuration

**●Absolute Maximum Ratings (Ta=25°C)**

Parameter	Symbol	Ratings	Unit
Power supply voltage	VMAX	7	V
Input voltage ( EN , PWMIN )	Vdin	GND-0.3 to VBAT+0.3	V
Power dissipation	Pd	900	mW
Operating temperature range	Topr	-30 to +85	°C
Storage temperature range	Tstg	-55 to +150	°C

(Note) Power dissipation deleting is 7.2mW/°C, when it's used in over 25°C.(It's deleting is on the board that is ROHM's standard)  
Dissipation by LSI should not exceed tolerance level of Pd.

**●Recommended Operating Rating (Ta = -30 to 85 °C)**

Parameter	Symbol	Limits	Unit
Operating power supply voltage	VBAT	2.7 to 5.5	V

**●Electrical Characteristics (Unless otherwise noted, Ta = +25°C, VBAT=3.6V)**

Parameter	Symbol	Limits			Units	Condition
		Min.	Typ.	Max.		
Current Consumption						
Quiescent Current	Iq	-	0.1	1	μA	EN=0V
Current Consumption1	Idd1	-	62	64	mA	x 1.0 Mode Include LED current (60mA)
Current Consumption2	Idd2	-	123	126	mA	x 2.0 Mode Include LED current (60mA)
Charge Pump						
Oscillator frequency	fosc	0.56	0.85	1.14	MHz	
Current Source						
LED maximum current	ILED-max	18	20	22	mA	VBAT≥3.2V
LED current accuracy	ILED-diff	-	-	10.0	%	LED current setting is 10.0mA, LED terminal voltage is 1.0V
LED current matching	ILED-match	-	0.5	5.0	%	LED current setting is 10.0mA, LED terminal voltage is 1.0V
LED control voltage	VLED	-	0.15	0.25	V	Minimum voltage from LED1 to LED6 pins
Logic control terminal						
Low threshold voltage	VIL	-	-	0.4	V	EN, PWMIN
High threshold voltage	VIH	1.4	-	-	V	EN, PWMIN
High level Input current	IiH	-	0	1	μA	EN = VBAT, PWMIN = VBAT
Low level Input current	IiL	-1	0	-	μA	EN = 0V, PWMIN = 0V
Minimum EN High time	THI	0.05	-	100	μs	Described in Figure 4.
Minimum EN Low time	TLO	0.3	-	100	μs	Described in Figure 4.
EN Off Timeout	TOFF	1	-	-	ms	Described in Figure 4.
Latch time	TLAT	1	-	-	ms	Described in Figure 4.
Access available time	Tacc	1	-	5	ms	Described in Figure 4.

●Pin Descriptions

Pin No.	Terminal No.	Pin Name	In/Out	Type	Function
1	D4	VBAT	-	A	Power supply
2	B4	C1P	In/Out	A	Flying capacitor pin positive (+) side
3	C4	C1N	In/Out	B	Flying capacitor pin negative (-) side
4	A4	C2P	In/Out	A	Flying capacitor pin positive (+) side
5	B3	C2N	In/Out	B	Flying capacitor pin negative (-) side
6	A3	VOUT	Out	A	Charge pump output
7	C3	EN	In	C	ON/OFF and dimming control
8	D1	LED1	Out	B	LED current driver output 1
9	D2	LED2	Out	B	LED current driver output 2
10	C1	LED3	Out	B	LED current driver output 3
11	C2	LED4	Out	B	LED current driver output 4
12	B1	LED5	Out	B	LED current driver output 5
13	A1	LED6	Out	A	LED current driver output 6
14	D3	PWMIN	In	C	PWM Control
15	A2	GND	-	D	GND

●Pin ESD Type

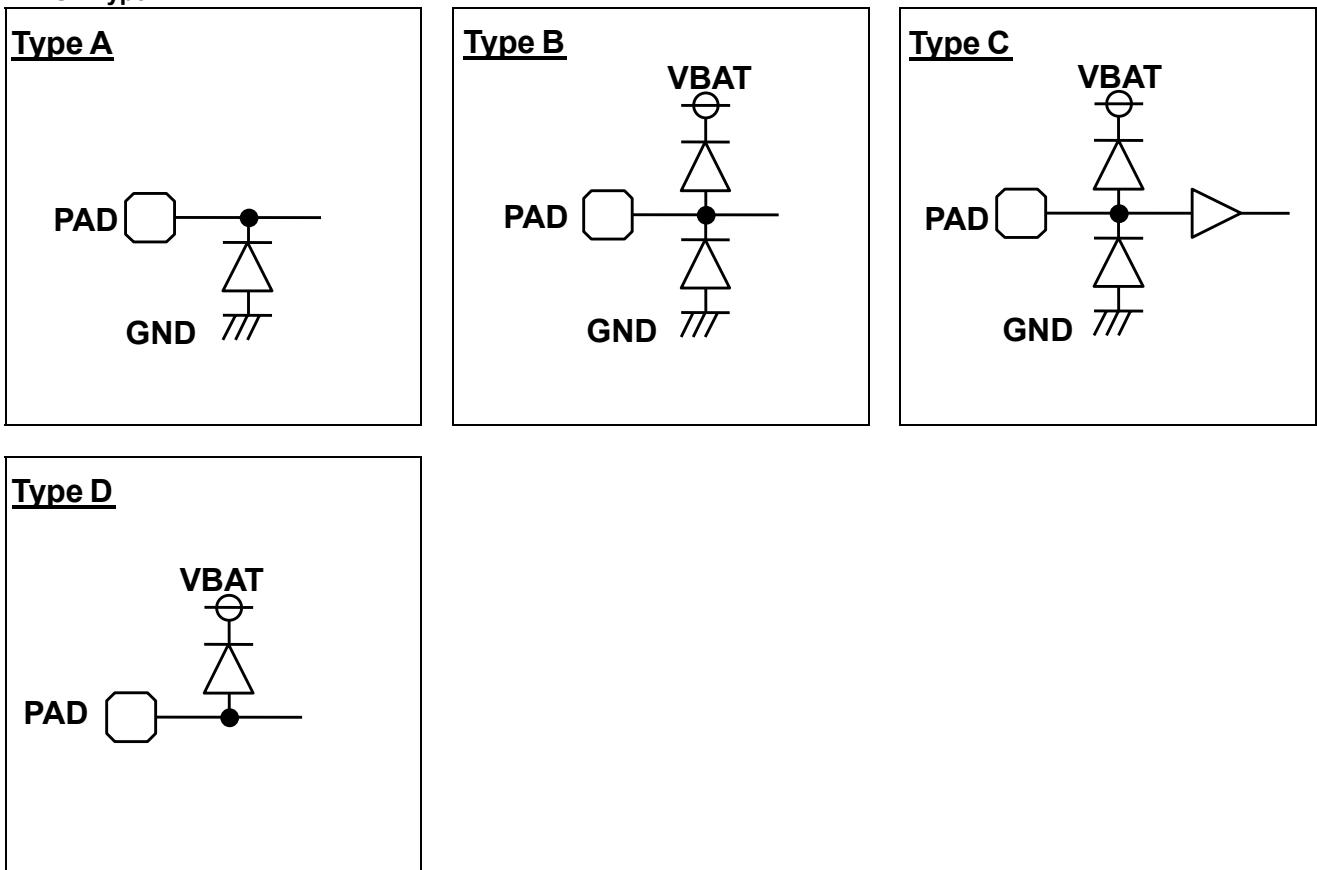

Figure 2. Pin ESD Type

●Block Diagram

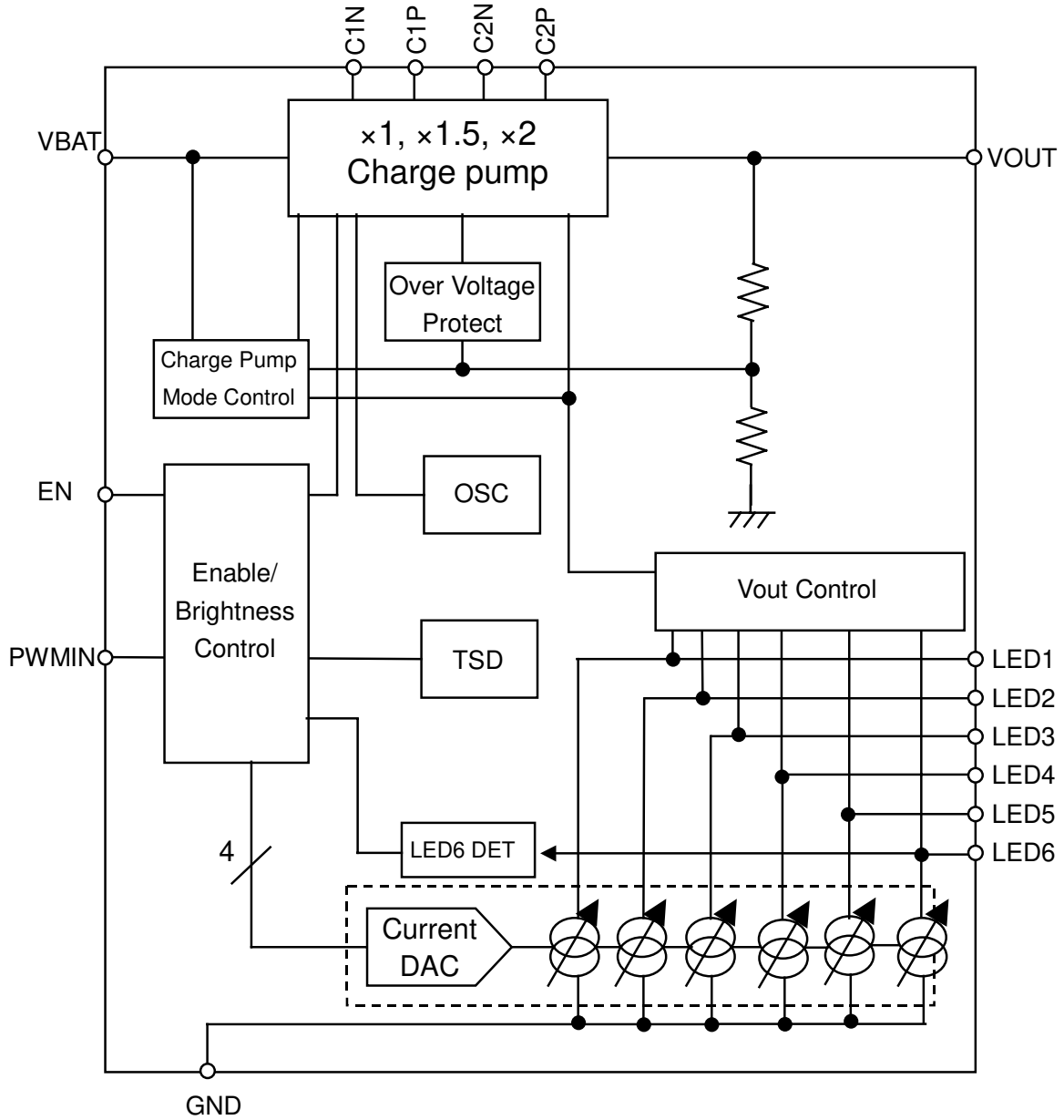

Figure 3. Block Diagram

●Separate Function Description

(1) LED driver

a) Register access control protocol

LED current is controlled by only EN terminal. It is possible to access the register inside of this chip by using the protocol below. Accessing the registers with using this protocol operates LED driver ON/OFF and selecting the mode. Moreover, MAX current can be outputted without Clock input to EN terminal by holding H zone of fixed time after EN terminal starting.

< When setting current level >

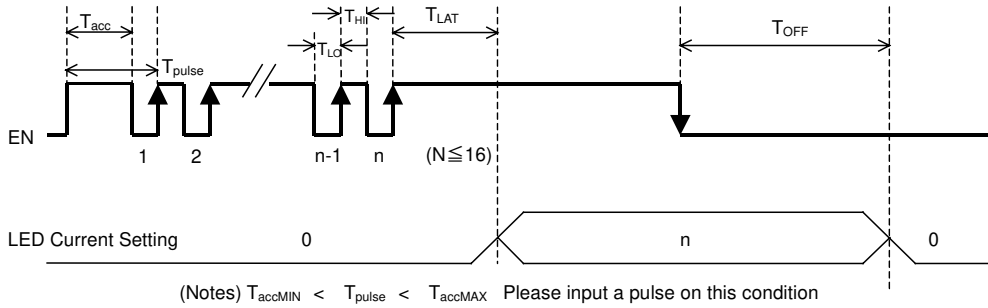

< When starting by MAX setup >

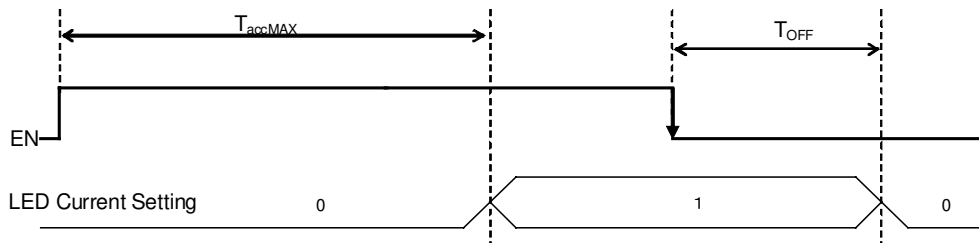

Figure 4. Register access protocol

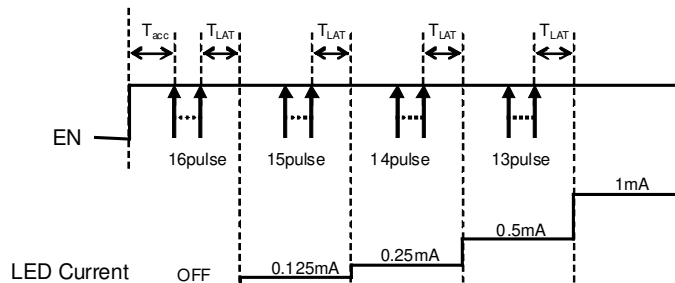

Figure 5. Slope control example

(Note)

- In the case of  $N > 16$ , BD1206GUL selects the mode of  $N = 16$ .
- LED current is changed by the pulse of EN pin.  
Be careful to noise of EN signal.
- Reset BD1206GUL when the set is unusual. (Keep EN=L over Toff time.)

## b) LED current level

The interface records rising edges of the EN pin and decodes them into 16 different indicated in following table.

Data	Output current [mA]	Data	Output current [mA]
1	20.0	9	5.0
2	17.0	10	4.0
3	14.0	11	3.0
4	12.0	12	2.0
5	10.0	13	1.0
6	8.5	14	0.5
7	7.0	15	0.25
8	6.0	16	0.125

## (2) Charge pump

## a) Description of operations

Pin voltage comparison takes place at Vout control section, and then Vout generation takes place so that the LED cathode voltage with the highest Vf is set to 0.15V. A boost rate is changed automatically to a proper one at the Charge Pump Mode Control section so that operation can take place at possible low boost rate. In addition, when the VOUT output is short-circuited to GND, the leak current is suppressed via the over current protection function.

## b) Soft start function

BD1206GUL have a soft start function that prevents the rush current.

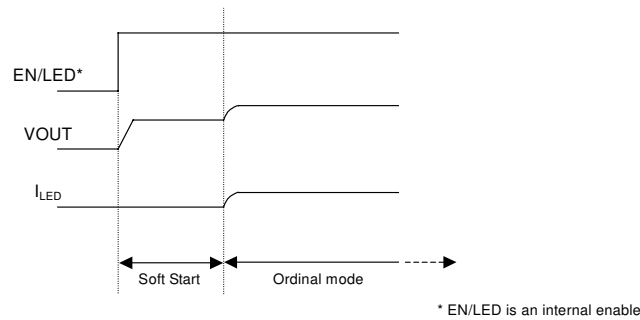

Figure 6. Soft Start

## c) Automatic boost rate change

The boost rate automatically switches to the best mode.

\* (x1 mode → x1.5 mode) or (x1.5 mode → x2 mode)

If a battery voltage drop occurs BD1206GUL cannot maintain the LED constant current, and then mode transition begins.

\* (x1.5 mode → x1 mode) or (x2 mode → x1.5 mode)

If a battery voltage rise occurs, VOUT and VBAT detection are activated, and then mode transition begins.

## (3) UVLO (Under Voltage Lock Out)

If the input voltage falls below 2.2V(Typ.), BD1206GUL is shut down to prevent malfunction due to ultra-low voltage.

## (4) OVP (Over Voltage Protection)

This circuit protects this IC against damage when the C/P output voltage (VOUT) rises extremely for some external factors.

## (5) Thermal shutdown (TSD)

To protect this IC against thermal damage or heat-driven uncontrolled operations, this circuit turns off the output if the chip temperature rises over 175°C. In addition, it turns on the output if the temperature returns to the normal temperature. Because the built-in thermal protection circuit is intended to protect the IC itself, the thermal shutdown detection temperature must be set to below 175°C in thermal design.

- (6) Power sequence  
 EN signal must be released after VBAT voltage enough rise up.  
 Prohibit the VBAT rise up during EN="H".

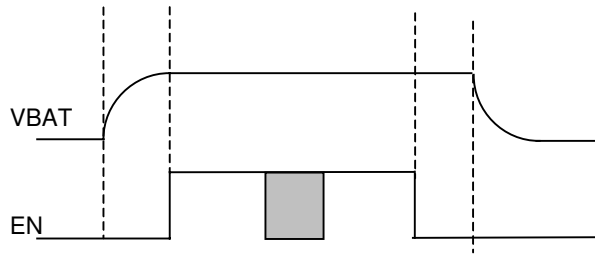

Figure 7. Power sequence

- (7) PWM control  
 PWM control by the external terminal (PWMIN) is possible.  
 It becomes PWM operation, which used LED current by a register setup as the base and is the best for the brightness compensation by external control. If the application with is not use PWM, PWMIN pin must be short to VBAT.

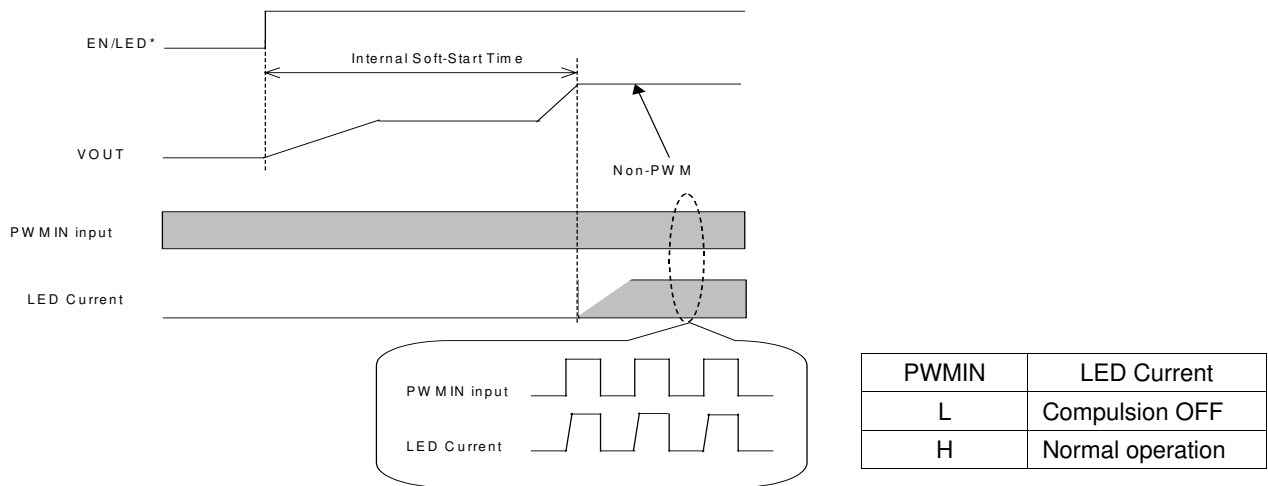

Figure 8. External PWM input solution

It is possible to make it a PWMIN input before EN/LED\* is "H".  
 A PWM drive becomes effective after the time of LED current standup.

When rising during PWM operation, as for the standup time of VOUT, only the rate of PWM Duty becomes late.  
 Appearance may be influenced when extremely late frequency and extremely low Duty are inputted.  
 Please secure over 120 μs "H" sections at the time of PWM pulse Force.

EN/LED\* is an internal enable signal

●Application Circuit Example (6 light with PWM)

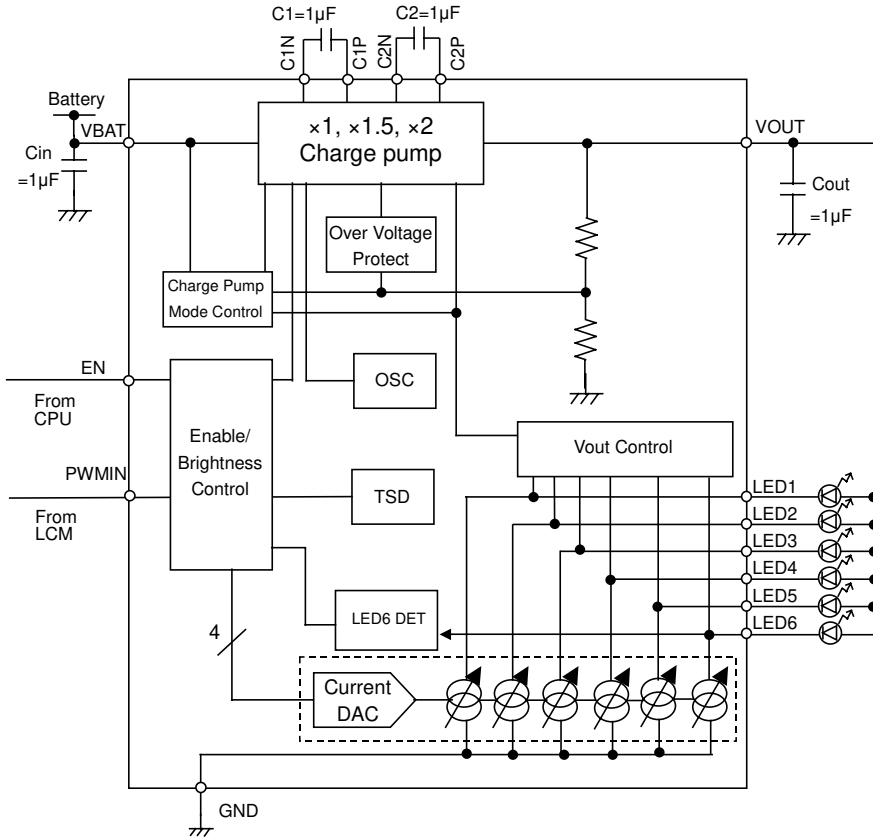

Figure 9. Application Circuit Example 1

●Application Circuit Example (5 light with PWM)

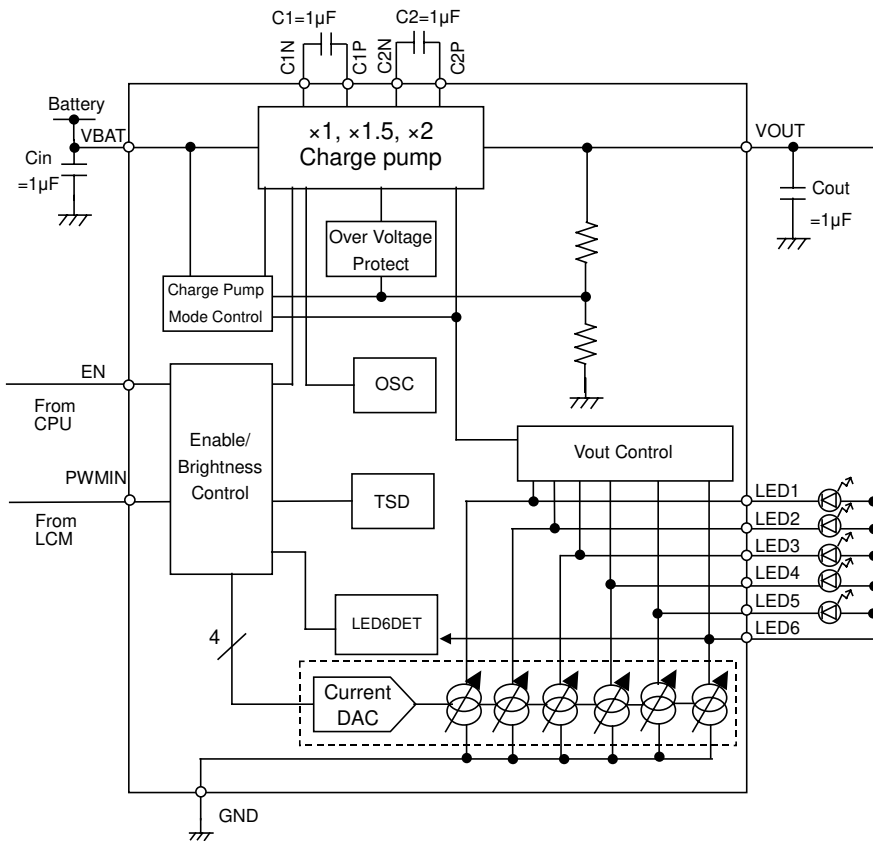

Figure 10. Application Circuit Example 2



●Application Circuit Example (6 light without PWM)

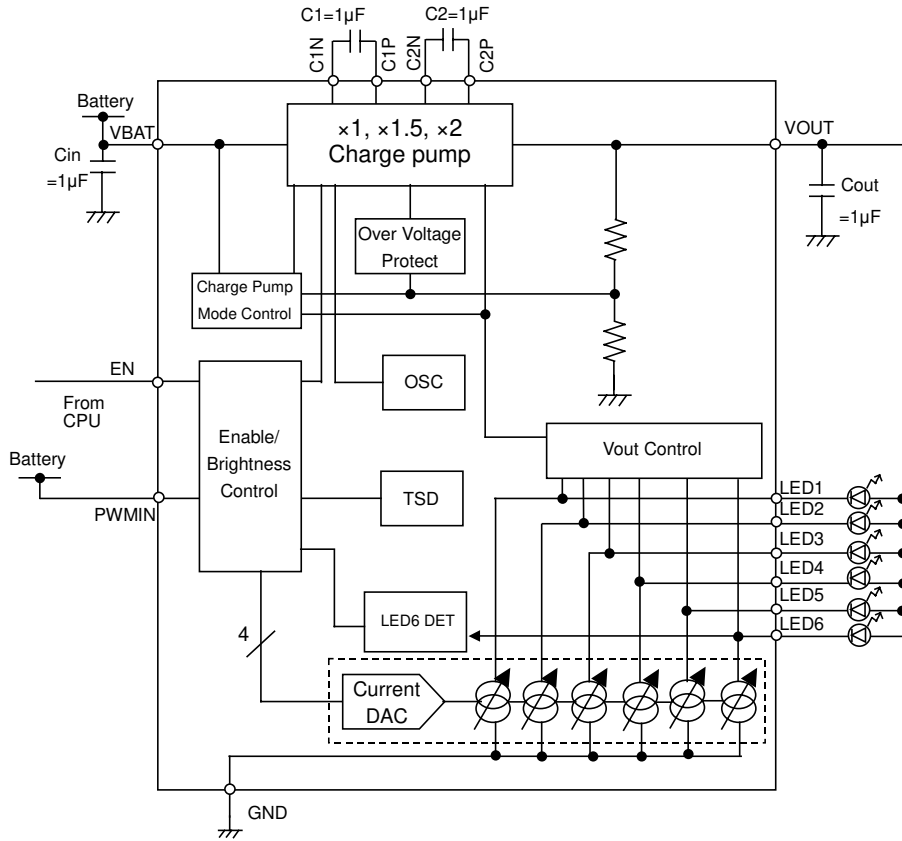

Figure 11. Application Circuit Example 3

**●Operational Notes**

- (1) Absolute Maximum Ratings  
An excess in the absolute maximum ratings, such as supply voltage, temperature range of operating conditions, etc., can break down devices, thus making impossible to identify breaking mode such as a short circuit or an open circuit. If any special mode exceeding the absolute maximum ratings is assumed, consideration should be given to take physical safety measures including the use of fuses, etc.
- (2) Power Supply and Ground Line  
Design PCB pattern to provide low impedance for the wiring between the power supply and the ground lines. Pay attention to the interference by common impedance of layout pattern when there are plural power supplies and ground lines. Especially, when there are ground pattern for small signal and ground pattern for large current included the external circuits, please separate each ground pattern. Furthermore, for all power supply pins to ICs, mount a capacitor between the power supply and the ground pin. At the same time, in order to use a capacitor, thoroughly check to be sure the characteristics of the capacitor to be used present no problem including the occurrence of capacity dropout at a low temperature, thus determining the constant.
- (3) Ground Voltage  
Make setting of the potential of the ground pin so that it will be maintained at the minimum in any operating state. Furthermore, check to be sure no pins are at a potential lower than the ground voltage including an actual electric transient.
- (4) Short Circuit between Pins and Erroneous Mounting  
In order to mount ICs on a set PCB, pay thorough attention to the direction and offset of the ICs. Erroneous mounting can break down the ICs. Furthermore, if a short circuit occurs due to foreign matters entering between pins or between the pin and the power supply or the ground pin, the ICs can break down.
- (5) Operation in strong electromagnetic field  
Be noted that using ICs in the strong electromagnetic field can malfunction them.
- (6) Input Pins  
In terms of the construction of IC, parasitic elements are inevitably formed in relation to potential. The operation of the parasitic element can cause interference with circuit operation, thus resulting in a malfunction and then breakdown of the input pin. Therefore, pay thorough attention not to handle the input pins, such as to apply to the input pins a voltage lower than the ground respectively, so that any parasitic element will operate. Furthermore, do not apply a voltage to the input pins when no power supply voltage is applied to the IC. In addition, even if the power supply voltage is applied, apply to the input pins a voltage lower than the power supply voltage or within the guaranteed value of electrical characteristics.
- (7) External Capacitor  
In order to use a ceramic capacitor as the external capacitor, determine the constant with consideration given to a degradation in the nominal capacitance due to DC bias and changes in the capacitance due to temperature, etc.
- (8) Thermal Shutdown Circuit  
This LSI builds in a thermal shutdown circuit. When junction temperatures become detection temperature or higher, the thermal shutdown circuit operates and turns a switch OFF. The thermal shutdown circuit, which is aimed at isolating the LSI from thermal runaway as much as possible, is not aimed at the protection or guarantee of the LSI. Therefore, do not continuously use the LSI with this circuit operating or use the LSI assuming its operation.
- (9) Thermal Design  
Perform thermal design in which there are adequate margins by taking into account the permissible dissipation (Pd) in actual states of use.
- (10) About the Pin for the Test, the un-use pin  
Prevent a problem from being in the pin for the test and the un-use pin under the state of actual use. Please refer to this Datasheet. And, as for the pin that doesn't specially have an explanation, ask our company person in charge.
- (11) About the Rush Current  
For ICs with more than one power supply, it is possible that rush current may flow instantaneously due to the internal powering sequence and delays. Therefore, give special consideration to power coupling capacitance, power wiring, width of ground wiring, and routing of wiring.

**Status of this document**

The Japanese version of this document is formal specification. A customer may use this translation version only for a reference to help reading the formal version.

If there are any differences in translation version of this document formal version takes priority.

●Ordering Information

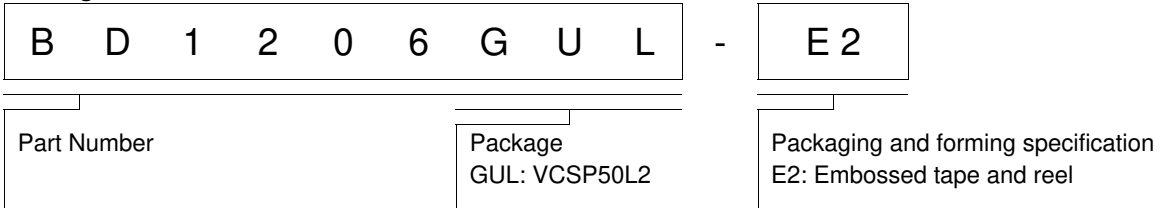

●Marking Diagram

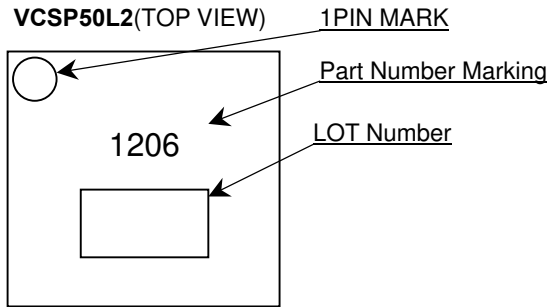

●Physical Dimension Tape and Reel Information

VCSP50L2(BD1206GUL)

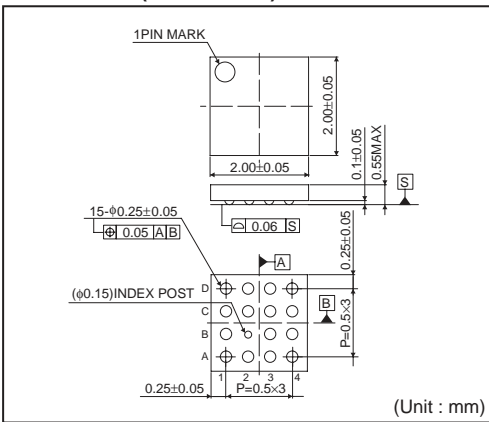

<Tape and Reel information>

Tape	Embossed carrier tape (heat sealing method)
Quantity	3000pcs
Direction of feed	E2 ( The direction is the 1pin of product is at the upper left when you hold reel on the left hand and you pull out the tape on the right hand )

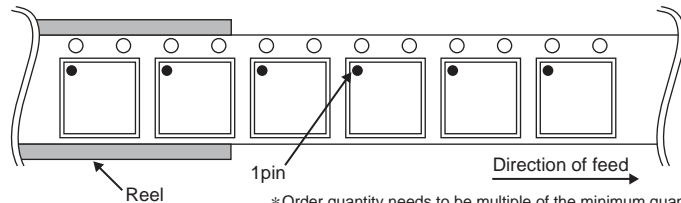

\*Order quantity needs to be multiple of the minimum quantity.

●Revision History

Date	Revision	Changes
02.Oct.2012	001	New Release

# Notice

## Precaution on using ROHM Products

- Our Products are designed and manufactured for application in ordinary electronic equipments (such as AV equipment, OA equipment, telecommunication equipment, home electronic appliances, amusement equipment, etc.). If you intend to use our Products in devices requiring extremely high reliability (such as medical equipment <sup>(Note 1)</sup>, transport equipment, traffic equipment, aircraft/spacecraft, nuclear power controllers, fuel controllers, car equipment including car accessories, safety devices, etc.) and whose malfunction or failure may cause loss of human life, bodily injury or serious damage to property ("Specific Applications"), please consult with the ROHM sales representative in advance. Unless otherwise agreed in writing by ROHM in advance, ROHM shall not be in any way responsible or liable for any damages, expenses or losses incurred by you or third parties arising from the use of any ROHM's Products for Specific Applications.

(Note1) Medical Equipment Classification of the Specific Applications

JAPAN	USA	EU	CHINA
CLASS III	CLASS III	CLASS II b	CLASS III
CLASS IV		CLASS III	

- ROHM designs and manufactures its Products subject to strict quality control system. However, semiconductor products can fail or malfunction at a certain rate. Please be sure to implement, at your own responsibilities, adequate safety measures including but not limited to fail-safe design against the physical injury, damage to any property, which a failure or malfunction of our Products may cause. The following are examples of safety measures:
  - Installation of protection circuits or other protective devices to improve system safety
  - Installation of redundant circuits to reduce the impact of single or multiple circuit failure
- Our Products are designed and manufactured for use under standard conditions and not under any special or extraordinary environments or conditions, as exemplified below. Accordingly, ROHM shall not be in any way responsible or liable for any damages, expenses or losses arising from the use of any ROHM's Products under any special or extraordinary environments or conditions. If you intend to use our Products under any special or extraordinary environments or conditions (as exemplified below), your independent verification and confirmation of product performance, reliability, etc. prior to use, must be necessary:
  - Use of our Products in any types of liquid, including water, oils, chemicals, and organic solvents
  - Use of our Products outdoors or in places where the Products are exposed to direct sunlight or dust
  - Use of our Products in places where the Products are exposed to sea wind or corrosive gases, including Cl<sub>2</sub>, H<sub>2</sub>S, NH<sub>3</sub>, SO<sub>2</sub>, and NO<sub>2</sub>
  - Use of our Products in places where the Products are exposed to static electricity or electromagnetic waves
  - Use of our Products in proximity to heat-producing components, plastic cords, or other flammable items
  - Sealing or coating our Products with resin or other coating materials
  - Use of our Products without cleaning residue of flux (even if you use no-clean type fluxes, cleaning residue of flux is recommended); or Washing our Products by using water or water-soluble cleaning agents for cleaning residue after soldering
  - Use of the Products in places subject to dew condensation
- The Products are not subject to radiation-proof design.
- Please verify and confirm characteristics of the final or mounted products in using the Products.
- In particular, if a transient load (a large amount of load applied in a short period of time, such as pulse. is applied, confirmation of performance characteristics after on-board mounting is strongly recommended. Avoid applying power exceeding normal rated power; exceeding the power rating under steady-state loading condition may negatively affect product performance and reliability.
- De-rate Power Dissipation (Pd) depending on Ambient temperature (Ta). When used in sealed area, confirm the actual ambient temperature.
- Confirm that operation temperature is within the specified range described in the product specification.
- ROHM shall not be in any way responsible or liable for failure induced under deviant condition from what is defined in this document.

## Precaution for Mounting / Circuit board design

- When a highly active halogenous (chlorine, bromine, etc.) flux is used, the residue of flux may negatively affect product performance and reliability.
- In principle, the reflow soldering method must be used; if flow soldering method is preferred, please consult with the ROHM representative in advance.

For details, please refer to ROHM Mounting specification

**Precautions Regarding Application Examples and External Circuits**

1. If change is made to the constant of an external circuit, please allow a sufficient margin considering variations of the characteristics of the Products and external components, including transient characteristics, as well as static characteristics.
2. You agree that application notes, reference designs, and associated data and information contained in this document are presented only as guidance for Products use. Therefore, in case you use such information, you are solely responsible for it and you must exercise your own independent verification and judgment in the use of such information contained in this document. ROHM shall not be in any way responsible or liable for any damages, expenses or losses incurred by you or third parties arising from the use of such information.

**Precaution for Electrostatic**

This Product is electrostatic sensitive product, which may be damaged due to electrostatic discharge. Please take proper caution in your manufacturing process and storage so that voltage exceeding the Products maximum rating will not be applied to Products. Please take special care under dry condition (e.g. Grounding of human body / equipment / solder iron, isolation from charged objects, setting of ionizer, friction prevention and temperature / humidity control).

**Precaution for Storage / Transportation**

1. Product performance and soldered connections may deteriorate if the Products are stored in the places where:
  - [a] the Products are exposed to sea winds or corrosive gases, including Cl<sub>2</sub>, H<sub>2</sub>S, NH<sub>3</sub>, SO<sub>2</sub>, and NO<sub>2</sub>
  - [b] the temperature or humidity exceeds those recommended by ROHM
  - [c] the Products are exposed to direct sunshine or condensation
  - [d] the Products are exposed to high Electrostatic
2. Even under ROHM recommended storage condition, solderability of products out of recommended storage time period may be degraded. It is strongly recommended to confirm solderability before using Products of which storage time is exceeding the recommended storage time period.
3. Store / transport cartons in the correct direction, which is indicated on a carton with a symbol. Otherwise bent leads may occur due to excessive stress applied when dropping of a carton.
4. Use Products within the specified time after opening a humidity barrier bag. Baking is required before using Products of which storage time is exceeding the recommended storage time period.

**Precaution for Product Label**

QR code printed on ROHM Products label is for ROHM's internal use only.

**Precaution for Disposition**

When disposing Products please dispose them properly using an authorized industry waste company.

**Precaution for Foreign Exchange and Foreign Trade act**

Since our Products might fall under controlled goods prescribed by the applicable foreign exchange and foreign trade act, please consult with ROHM representative in case of export.

**Precaution Regarding Intellectual Property Rights**

1. All information and data including but not limited to application example contained in this document is for reference only. ROHM does not warrant that foregoing information or data will not infringe any intellectual property rights or any other rights of any third party regarding such information or data. ROHM shall not be in any way responsible or liable for infringement of any intellectual property rights or other damages arising from use of such information or data.:
2. No license, expressly or implied, is granted hereby under any intellectual property rights or other rights of ROHM or any third parties with respect to the information contained in this document.

**Other Precaution**

1. This document may not be reprinted or reproduced, in whole or in part, without prior written consent of ROHM.
2. The Products may not be disassembled, converted, modified, reproduced or otherwise changed without prior written consent of ROHM.
3. In no event shall you use in any way whatsoever the Products and the related technical information contained in the Products or this document for any military purposes, including but not limited to, the development of mass-destruction weapons.
4. The proper names of companies or products described in this document are trademarks or registered trademarks of ROHM, its affiliated companies or third parties.

**General Precaution**

1. Before you use our Products, you are requested to carefully read this document and fully understand its contents. ROHM shall not be in any way responsible or liable for failure, malfunction or accident arising from the use of any ROHM's Products against warning, caution or note contained in this document.
2. All information contained in this document is current as of the issuing date and subject to change without any prior notice. Before purchasing or using ROHM's Products, please confirm the latest information with a ROHM sales representative.
3. The information contained in this document is provided on an "as is" basis and ROHM does not warrant that all information contained in this document is accurate and/or error-free. ROHM shall not be in any way responsible or liable for any damages, expenses or losses incurred by you or third parties resulting from inaccuracy or errors of or concerning such information.