

REVISIONS					
REV	DESCRIPTION	DATE	BY	CHK	APP'D
R3	REVISED PER ECR-21-118795	28JUL2022	SK	VS	

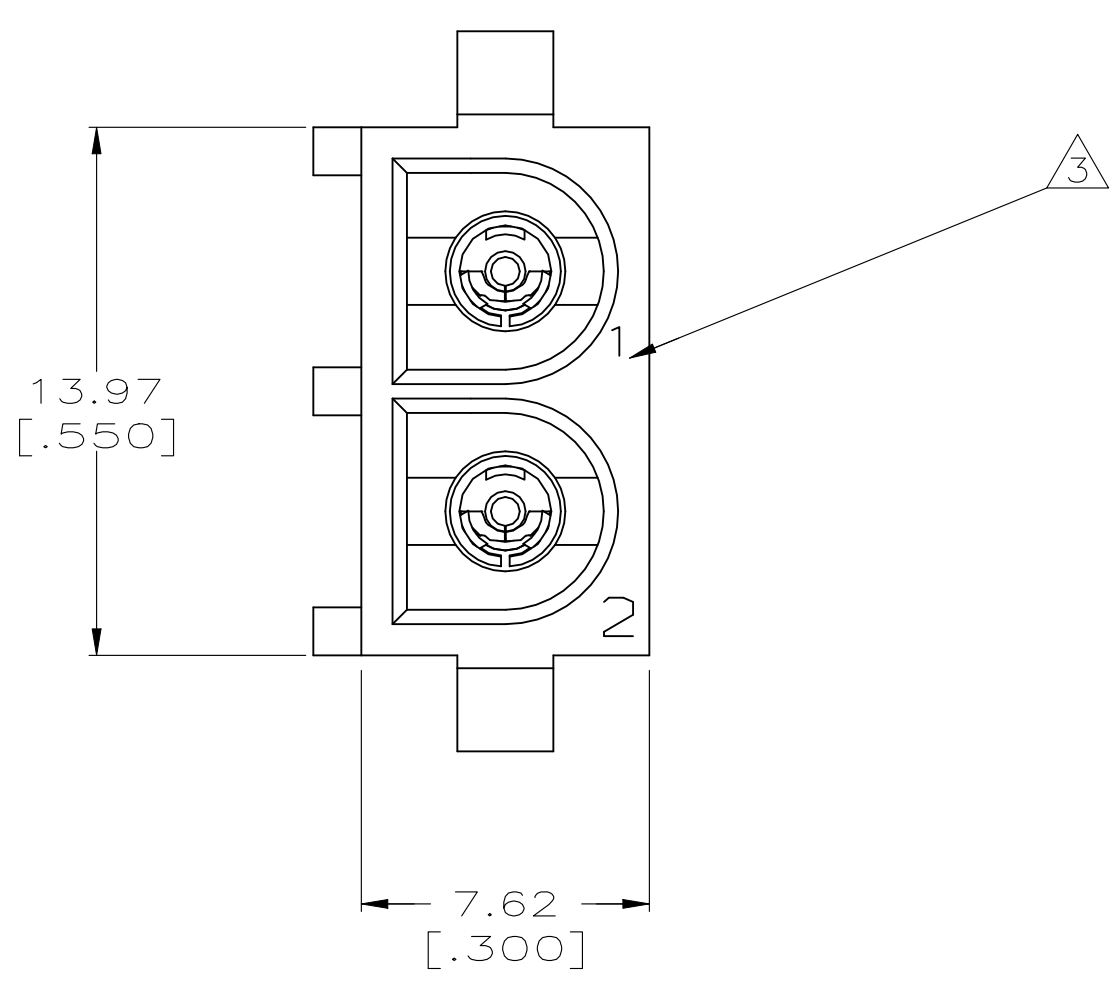

- 1 PARTS COMPLY TO AMP SOLDERABILITY SPECIFICATION 109-11-3.
- 2 CONTACT IS PLATED OVERALL WITH 0.00127 [.000050] NICKEL, THEN 0.00076 [.000030] GOLD OVER CONTACT LENGTH INDICATED AND MATTE TIN LEAD ON SOLDER TAIL END.
- 3 CIRCUIT IDENTIFICATION CHARACTERS ARE ADJACENT TO THE INDICATED CAVITIES, BUT LOCATION AND ORIENTATION MAY DIFFER FROM PRINT.
- 4 DIMENSIONS IN BRACKETS ARE IN INCHES.
- 5 CONTACT IS PLATED OVERALL WITH 0.00127 [.000050] NICKEL, THEN 0.00076 [.000030] GOLD OVER CONTACT LENGTH INDICATED AND MATTE TIN ON SOLDER TAIL END.
- 6 SUPERSEDED BY 350759-5
- 7 DIMENSIONS WITH REPRESENT PRODUCT IN DRY CONDITION. ADDITIONAL 2% GROWTH DUE TO END USE LOCATION MOISTURE ABSORPTION MAY OCCUR AND SHOULD BE ACCOUNTED FOR.

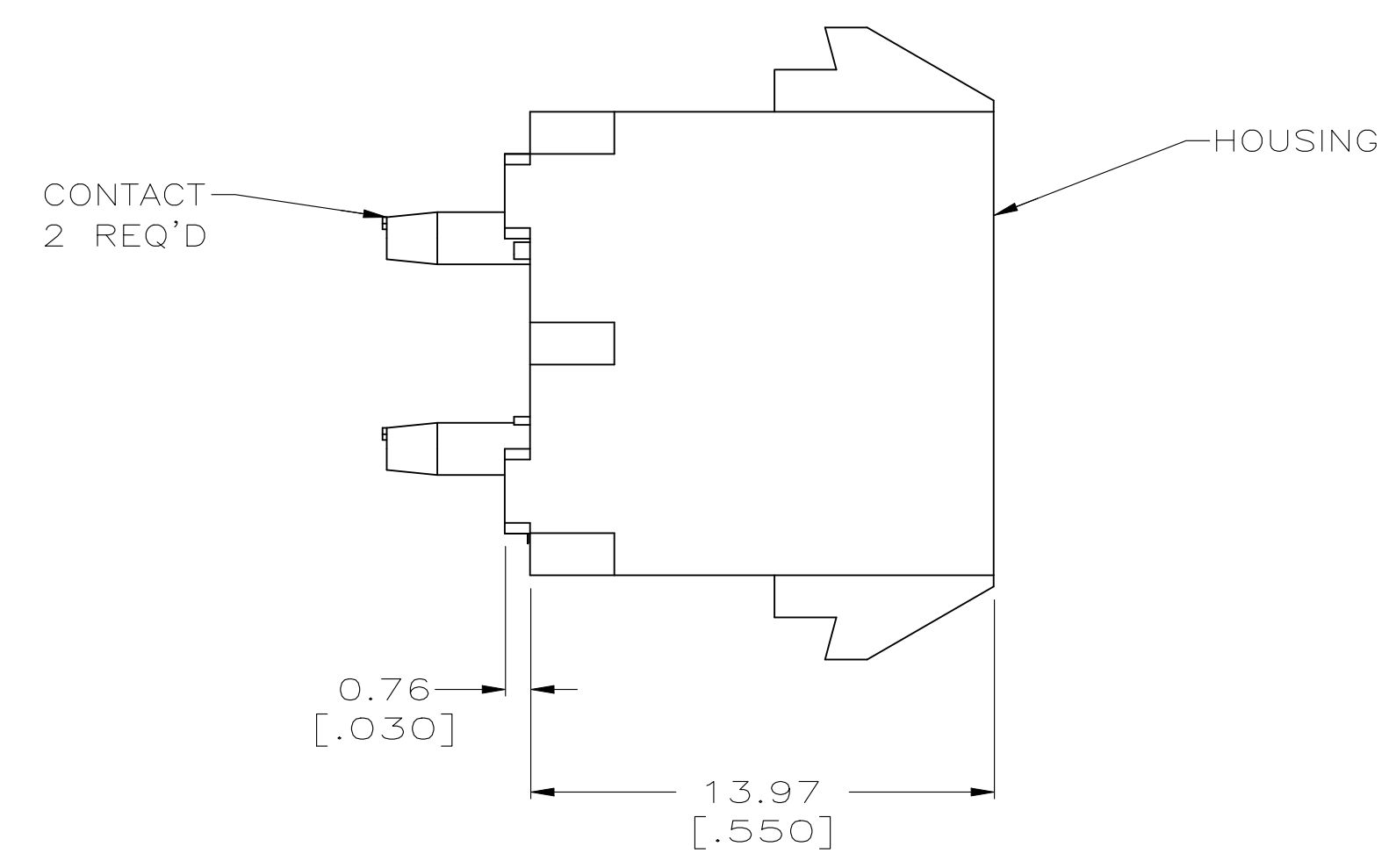
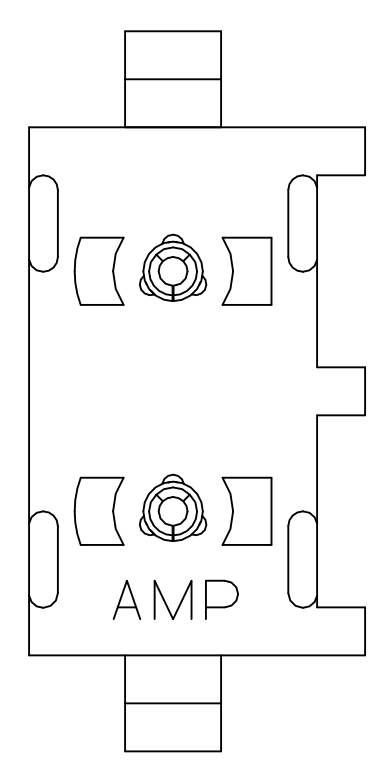
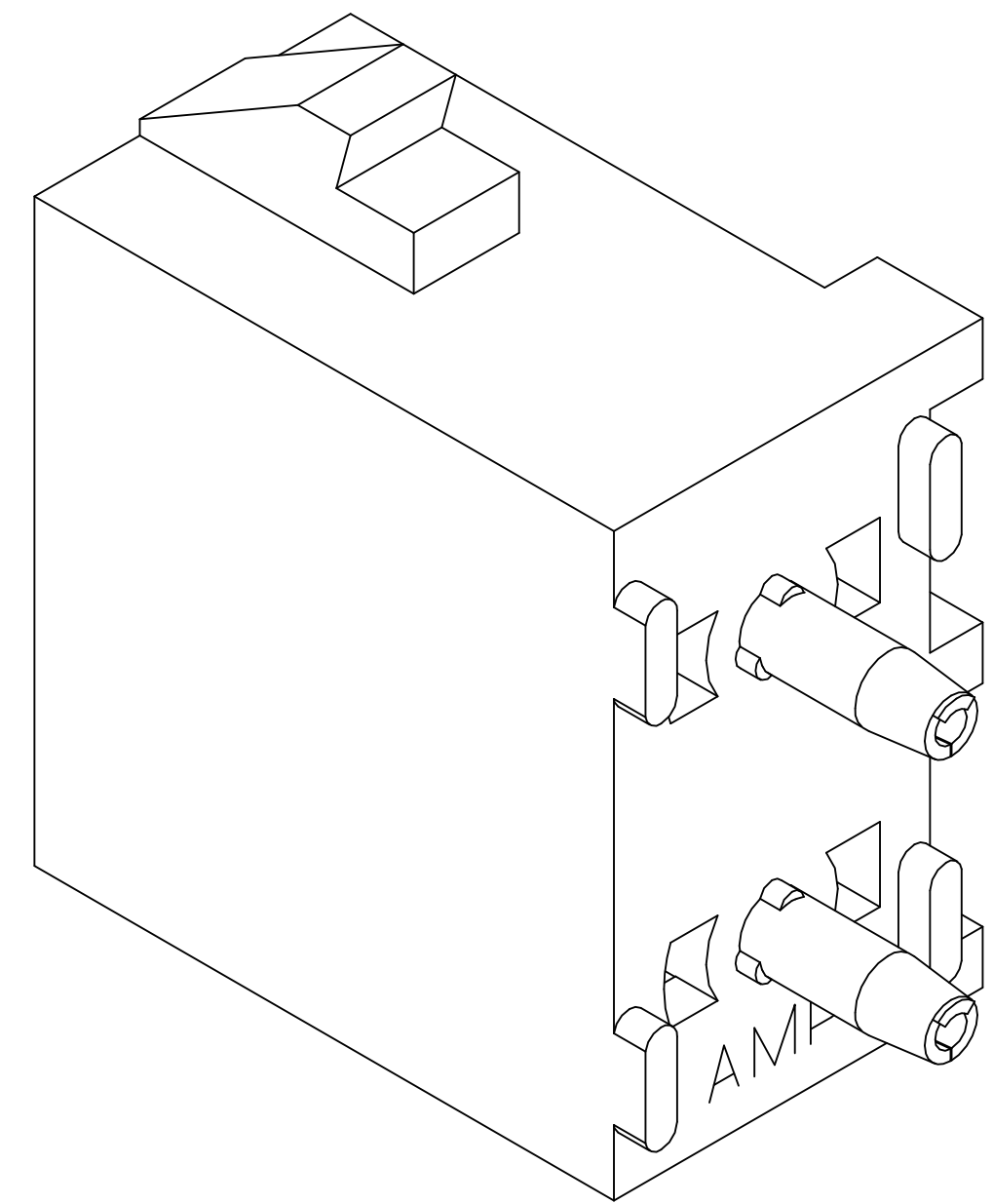

3-DIMENSIONAL MODEL NTS

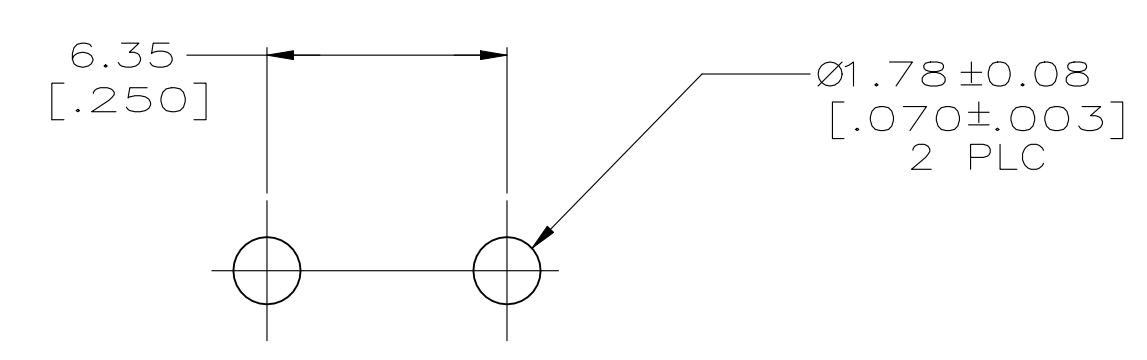
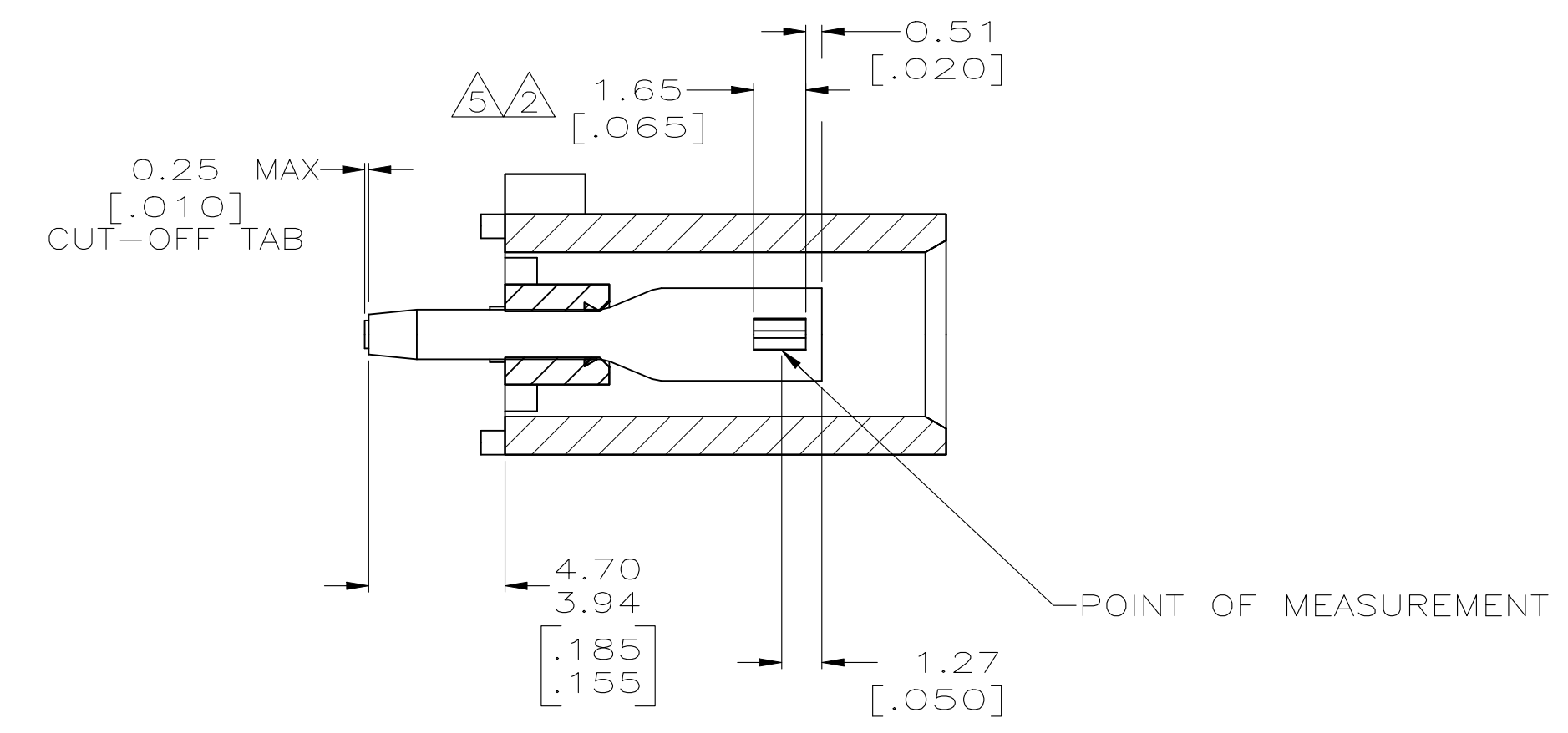

RECOMMENDED MOUNTING HOLE PATTERN FOR 1.57 [.062] THICK P.C. BOARD

PHOSPHOR BRONZE, GOLD 5	NYLON,UL94V-2,NATURAL	350759-5
PHOSPHOR BRONZE, PRE-TIN	NYLON,UL94V-2,NATURAL	350759-4
PHOSPHOR BRONZE, GOLD 2	NYLON,UL94V-2,NATURAL	350759-3
CONTACT MATERIAL AND FINISH	HOUSING MATERIAL	PART NUMBER

THIS DRAWING IS A CONTROLLED DOCUMENT.		DIN K. WHITAKER 21JULY2005	TE Connectivity	
DIMENSIONS: mm [NCHES]		CHK S. RIDGILL 21JULY2005		
TOLERANCES UNLESS OTHERWISE SPECIFIED:		APP'D S. RIDGILL 21JULY2005	NAME	
0 PLC ± -			PRODUCT SPEC	
1 PLC ± -			APPLICATION SPEC	
2 PLC ± 0.13 [.005]			SIZE CAGE CODE DRAWING NO	
3 PLC ± -			RESTRICTED TO	
4 PLC ± -			WEIGHT 0.000000 A1 00779 C=350759	
ANGLES ± # 0°30'			CUSTOMER DRAWING SCALE 5:1 SHEET 1 OF 1 REV R3	