

LCD-2B

Small Flat Panel Table/Desk Mount

Product Features:

Can be attached as a clamp-on or bolt through mount with parts provided

Holds 10" – 23" flat panels

Accommodates panels with 75 or 100 mm VESA hole patterns

Rotates 360° / Adjustable -5° to +30° tilt

Force arm has adjustable 0° to 60° forward tilt

Load capacity - 25 lbs

Black powder coat finish

Available in silver finish (LCD-2)

Product Specifications:

(for Architects & Engineers)

The table/desk mount for the flat panel display shall be the Video Mount Products (VMP) model LCD-2B. The mount shall be constructed primarily of formed steel and shall incorporate nylon filled nuts. The mount shall be a universal style mount capable of mounting to all 10" - 23" flat panels that incorporate 75mm and 100mm VESA standard mounting hole patterns and not necessarily be model specific. The mount shall include both 75mm and 100mm mounting plates. The mount shall be capable of being configured as a clamp style or drill through with parts provided. The mount must allow for adjustable tilt from -5° to +30° at the head and 0° to 60° forward tilt. The load capacity shall be 25 lbs. The mount shall also be available in a silver finish (LCD-2).

Video Mount Products

345 Log Canoe Circle

Stevensville, MD 21666

Toll Free: 877.281.2169

Telephone: 410.643.6390

Facsimile: 410.643.6615

www.videomount.com

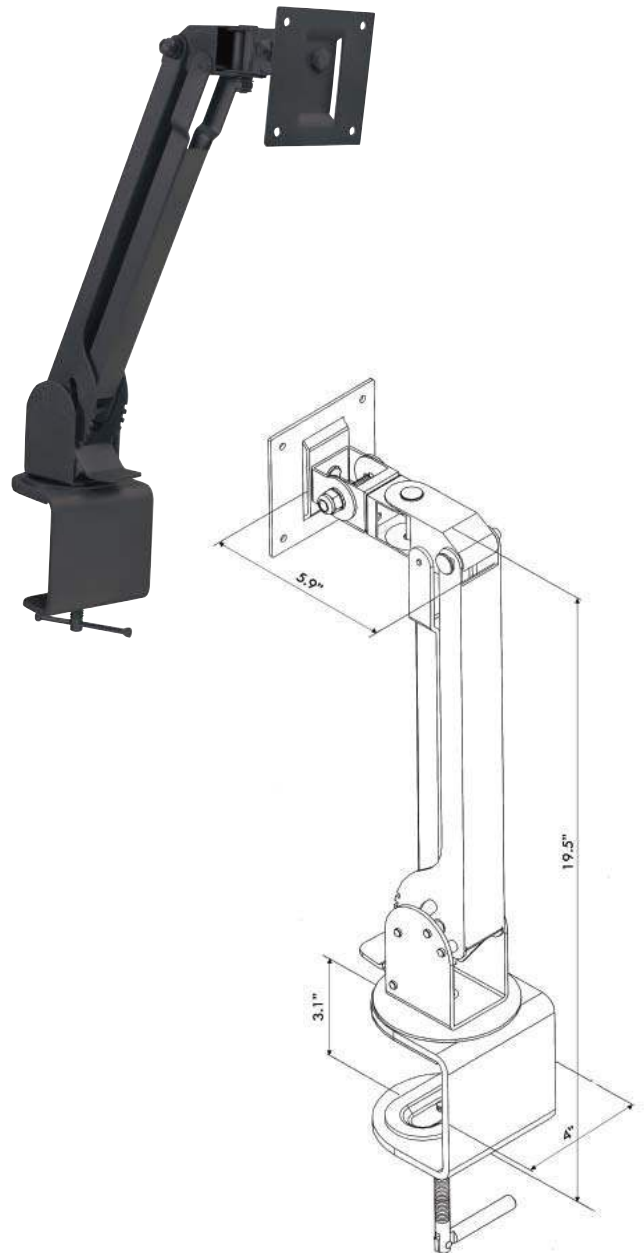

VMP
VIDEO MOUNT PRODUCTS