

TPD2S703-Q1 Automotive USB 2-Channel Data Line Short-to-Battery, Short-to-V_{BUS}, and IEC ESD Protection

1 Features

- AEC-Q100 Qualified
 - –40°C to +125°C Operating temperature range
- Short-to-battery (up to 18 V) and short-to-V_{BUS} protection on VD+, VD–
- ESD Performance VD+, VD–
 - ±8-kV Contact discharge (IEC 61000-4-2 and ISO 10605 330 pF, 330 Ω)
 - ±15-kV Air-gap discharge (IEC 61000-4-2 and ISO 10605 330 pF, 330 Ω)
- High speed data switches (1-GHz bandwidth)
- Only requires 5-V power supply
- Adjustable OVP threshold
- Fast Overvoltage response time (200 ns typical)
- Thermal shutdown feature
- Integrated input enable and fault output signal
- Flow-through routing for data Integrity
 - 10-pin VSSOP package (3 mm × 3 mm)
 - 10-pin WSON package (2.5 mm × 2.5 mm)

2 Applications

- End Equipment
 - Head unit
 - Rear seat entertainment
 - Telematics
 - USB hubs
 - Navigation modules
 - Media interface
- Interfaces
 - USB 2.0
 - USB 3.0

3 Description

The TPD2S703-Q1 is a 2-Channel Data Line Short-to-Battery, Short-to-V_{BUS}, and IEC61000-4-2 ESD protection device for automotive high-speed interfaces like USB 2.0. The TPD2S703-Q1 contains two data line nFET switches which ensure safe data communication by providing best in class bandwidth for minimal signal degradation while simultaneously protecting the internal system circuits from any overvoltage conditions at the VD+ and VD– pins. On these pins, this device can handle overvoltage protection up to 18-V DC. This provides sufficient protection for shorting the data lines to the car battery as well as the USB V_{BUS} rail. The overvoltage protection circuit provides the most reliable short-to-battery isolation in the industry, shutting off the data switches in 200 ns and protecting the upstream circuitry from harmful voltage and current spikes.

Additionally, the TPD2S703-Q1 only requires a single power supply of 5 V in order to optimize power tree size and cost. The OVP threshold and clamping circuit can be adjusted by a resistor divider network to provide a simple, cost effective way to optimize system protection for any transceiver. The TPD2S703-Q1 also includes a $\overline{\text{FLT}}$ pin which provides an indication when the device sees an overvoltage condition and automatically resets when the overvoltage condition is removed.

The TPD2S703-Q1 also integrates system level IEC 61000-4-2 and ISO 10605 ESD clamps on the VD+ and VD– pins, thus eliminating the need for external high voltage, low capacitance TVS clamp circuits in the application.

Device Information⁽¹⁾

PART NUMBER	PACKAGE	BODY SIZE (NOM)
TPD2S703-Q1	VSSOP (10)	3.00 mm × 3.00 mm
	WSON (10)	2.50 mm × 2.50 mm

(1) For all available packages, see the orderable addendum at the end of the data sheet.

USB 2.0 Port With Short-to-Battery and IEC ESD Protection

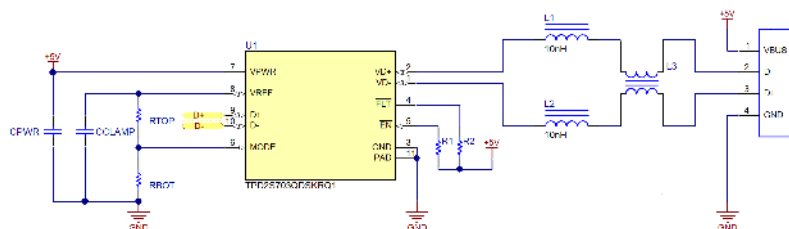

Table of Contents

1 Features	1	8.2 Functional Block Diagram	15
2 Applications	1	8.3 Feature Description.....	16
3 Description	1	8.4 Device Functional Modes.....	17
4 Revision History	2	9 Application and Implementation	18
5 Pin Configuration and Functions	3	9.1 Application Information.....	18
6 Specifications	4	9.2 Typical Application	18
6.1 Absolute Maximum Ratings	4	10 Power Supply Recommendations	21
6.2 ESD Ratings—AEC Specification	4	10.1 V _{PWR} Path	21
6.3 ESD Ratings—IEC Specification	4	10.2 V _{REF} Pin	21
6.4 ESD Ratings—ISO Specification	4	11 Layout	22
6.5 Recommended Operating Conditions.....	5	11.1 Layout Guidelines	22
6.6 Thermal Information	5	11.2 Layout Example	22
6.7 Electrical Characteristics.....	6	12 Device and Documentation Support	23
6.8 Power Supply and Supply Current Consumption Characteristics	8	12.1 Documentation Support	23
6.9 Timing Requirements.....	8	12.2 Receiving Notification of Documentation Updates	23
6.10 Typical Characteristics	11	12.3 Support Resources	23
7 Parameter Measurement Information	14	12.4 Trademarks	23
8 Detailed Description	15	12.5 Electrostatic Discharge Caution.....	23
8.1 Overview	15	12.6 Glossary	23
		13 Mechanical, Packaging, and Orderable Information	24

4 Revision History

NOTE: Page numbers for previous revisions may differ from page numbers in the current version.

Changes from Revision A (May 2017) to Revision B	Page
• Changed Figure USB 2.0 Port With Short-to-Battery and IEC ESD Protection image object for clarity	1
• Corrected cross reference hyperlink at the ESD Ratings tables	4
• Changed Figure 23 image object for clarity.....	18
• Added section Common choke and Inductor for VD+ and VD- for clarity.....	19

Changes from Original (March 2017) to Revision A	Page
• Updated description from enable to $\overline{\text{FLT}}$ in Recommended Operating Conditions table.....	5

5 Pin Configuration and Functions

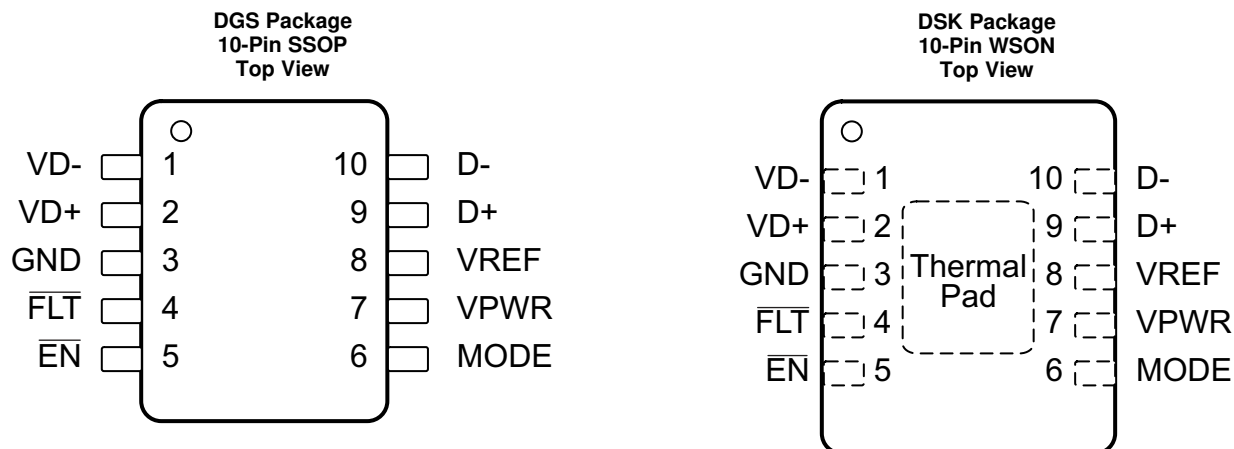

Pin Functions

PIN		TYPE	DESCRIPTION
NO.	NAME		
1	VD-	I/O	High voltage D- USB data line, connect to USB connector D+, D- IEC61000-4-2 ESD protection
2	VD+	I/O	High voltage D+ USB data line, connect to USB connector D+, D- IEC61000-4-2 ESD protection
3	GND	Ground	Ground pin for internal circuits and IEC ESD clamps
4	$\overline{\text{FLT}}$	O	Open-drain fault pin. See Table 1
5	$\overline{\text{EN}}$	I	Enable active-low input. Drive $\overline{\text{EN}}$ low to enable the switches. Drive $\overline{\text{EN}}$ high to disable the switches. See Table 1 for mode selection
6	MODE	I	Selects between device modes. See the Detailed Description section. Acts as LDO reference voltage for mode 1
7	VPWR	I	5-V DC supply input for internal circuits. Connect to internal power rail on PCB
8	VREF	I/O	Pin to set OVP threshold. See the Detailed Description section for instructions on how to set OVP threshold
9	D+	I/O	I/O protected low voltage D+ USB data line, connects to transceiver
10	D-	I/O	Protected low voltage D- USB data line, connects to transceiver

6 Specifications

6.1 Absolute Maximum Ratings

over operating free-air temperature range (unless otherwise noted) ⁽¹⁾ ⁽²⁾

		MIN	MAX	UNIT
V _{PWR}	5-V DC supply voltage for internal circuitry	-0.3	7.7	V
V _{REF}	Pin to set OVP threshold	-0.3	6	V
VD+, VD-	Voltage range from connector-side USB data lines	-0.3	18	V
D+, D-	Voltage range for internal USB data lines	-0.3	V _{REF} + 0.3	V
V _{MODE}	Voltage on MODE pin	-0.3	7.7	V
V _{FLT}	Voltage on FLT pin	-0.3	7.7	V
V _{EN}	Voltage on enable pin	-0.3	7.7	V
T _A	Operating free air temperature ⁽³⁾	-40	125	°C
T _{STG}	Storage temperature	-65	150	°C

- (1) Stresses beyond those listed under *Absolute Maximum Ratings* may cause permanent damage to the device. These are stress ratings only, which do not imply functional operation of the device at these or any other conditions beyond those indicated under *Recommended Operating Conditions*. Exposure to absolute-maximum-rated conditions for extended periods may affect device reliability.
- (2) The algebraic convention, whereby the most negative value is a minimum and the most positive value is a maximum.
- (3) Thermal limits and power dissipation limits must be observed.

6.2 ESD Ratings—AEC Specification

			VALUE	UNIT
V _(ESD)	Electrostatic discharge	Human-body model (HBM), per AEC Q100-002 ⁽¹⁾	All pins	±2000
		Charged-device model (CDM), per AEC Q100-011	All pins besides corners	±500
			Corner pins	±750

- (1) AEC Q100-002 indicates that HBM stressing shall be in accordance with the ANSI/ESDA/JEDEC JS-001 specification.

6.3 ESD Ratings—IEC Specification

			VALUE	UNIT
V _(ESD)	Electrostatic discharge	IEC 61000-4-2 contact discharge	VD+, VD- pins ⁽¹⁾	±8000
		IEC 61000-4-2 air-gap discharge	VD+, VD- pins ⁽¹⁾	±15000

- (1) See [Figure 20](#) for details on system level ESD testing setup.

6.4 ESD Ratings—ISO Specification

			VALUE	UNIT
V _{ESD} ⁽¹⁾	Electrostatic discharge	ISO 10605 (330 pF, 330 Ω) contact discharge (10 strikes)	VD+, VD- pins	±8000
		ISO 10605 (330 pF, 330 Ω) air-gap discharge (10 strikes)	VD+, VD- pins	±15000
		ISO 10605 (150 pF, 330 Ω) contact discharge (10 strikes)	VD+, VD- pins	±8000
		ISO 10605 (150 pF, 330 Ω) air-gap discharge (10 strikes)	VD+, VD- pins	±15000
		ISO 10605 (330 pF, 2 kΩ) contact discharge (10 strikes) ⁽²⁾	VD+, VD- pins	±8000
		ISO 10605 (330 pF, 2 kΩ) air-gap discharge (10 strikes)	VD+, VD- pins	±15000
		ISO 10605 (150 pF, 2 kΩ) air-gap discharge (10 discharges)	VD+, VD- pins	±25000

- (1) See [Figure 20](#) for details on system level ESD testing setup.
- (2) V_{REF} > 3 V.

6.5 Recommended Operating Conditions

over operating free-air temperature range (unless otherwise noted)

		MIN	TYP	MAX	UNIT
V _{PWR}	5-V DC supply voltage for internal circuitry	4.5		7	V
V _{REF}	Mode 0. Voltage range for V _{REF} pin (for setting OVP threshold)	3		3.6	V
V _{REF}	Mode 1. Voltage range for V _{REF} pin (for setting OVP threshold)	0.63		3.8	V
VD+, VD–	Voltage range from connector-side USB data lines	0		3.6	V
D+, D–	Voltage range for internal USB data lines	0		3.6	V
V _{EN}	Voltage range for enable	0		7	V
V _{FLT}	Voltage range for $\overline{\text{FLT}}$	0		7	V
I _{FLT}	Current into open drain $\overline{\text{FLT}}$ pin FET	0		3	mA
C _{VPWR}	V _{PWR} capacitance ⁽¹⁾	1	10		μF
C _{VREF}	V _{REF} capacitance	0.3	1	3	μF
C _{MODE}	Allowed parasitic capacitance on mode pin from PCB and mode 1 external resistors			20	pF
R _{MODE_0}	Resistance to GND to set to mode 0		2	2.6	kΩ
R _{MODE_1}	Resistance to GND to set to mode 1 (calculate parallel combination of R _{TOP} and R _{BOT})	14	20		kΩ

- (1) For recommended values for capacitors and resistors, the typical values assume a component placed on the board near the pin. Minimum and maximum values listed are inclusive of manufacturing tolerances, voltage derating, board capacitance, and temperature variation. The effective value presented should be within the minimum and maximums listed in the table.

6.6 Thermal Information

THERMAL METRIC ⁽¹⁾		TPD2S703-Q1		UNIT
		DGS (VSSOP)	DSK (WSON)	
		10 PINS	10 PINS	
θ _{JA}	Junction-to-ambient thermal resistance	167.3	61.5	°C/W
θ _{JCtop}	Junction-to-case (top) thermal resistance	56.9	51.3	°C/W
θ _{JB}	Junction-to-board thermal resistance	87.6	34	°C/W
ψ _{JT}	Junction-to-top characterization parameter	7.7	1.3	°C/W
ψ _{JB}	Junction-to-board characterization parameter	86.2	34.3	°C/W
θ _{JCbot}	Junction-to-case (bottom) thermal resistance	N/A	7.7	°C/W

- (1) For more information about traditional and new thermal metrics, see the [Semiconductor and IC Package Thermal Metrics](#) application report.

6.7 Electrical Characteristics

over operating free-air temperature range (unless otherwise noted)

PARAMETER		TEST CONDITIONS		MIN	TYP	MAX	UNIT
MODE 1 ADJUSTABLE V_{REF}							
V _{MODE_CMP}	Mode 1 V _{REF} feedback regulator voltage	V _{MODE}	Standard mode 1 set-up. $\overline{EN} = 0$ V. Once V _{REF} = 3.3 V, measure voltage on mode pin	0.47	0.5	0.53	V
I _{MODE_LEAK}	Mode pin mode 1 leakage current	I _{MODE}	Standard mode 1. Remove R _{TOP} and R _{BOT} . Power up device and wait until start-up time has passed. Then force 0.53 V on the MODE pin and measure current into pin		50	200	nA
V _{REF_ACCURACY}	V _{REF} accuracy	V _{REF}	Informative, test parameters below; accuracy with R _{TOP} and R _{BOT} as $\pm 1\%$ resistors	-8%		8%	
V _{REF_3.3V}	Mode 1 V _{REF} set to 3.3 V	V _{REF}	Standard mode 1 set-up. R _{TOP} = 140 k Ω \pm 1%, R _{BOT} = 24.9 k Ω \pm 1%. $\overline{EN} = 0$. Measure value of V _{REF} once it settles	3.04	3.31	3.58	V
V _{REF_0.66V}	Mode 1 V _{REF} set to 0.66 V	V _{REF}	Standard mode 1 set-up. R _{TOP} = 47.5 k Ω \pm 1%, R _{BOT} = 150 k Ω \pm 1%. $\overline{EN} = 0$. Measure value of V _{REF} once it settles	0.6	0.66	0.72	V
V _{REF_3.8V}	Mode 1 V _{REF} set to 3.8 V	V _{REF}	Standard mode 1 set-up. R _{TOP} = 165 k Ω \pm 1%, R _{BOT} = 24.9 k Ω \pm 1%. $\overline{EN} = 0$. Measure value of V _{REF} once it settles	3.5	3.81	4.12	V
EN, FLT PINS							
V _{IH}	High-level input voltage	\overline{EN}	Mode 0. Connect VPWR = 5 V; V _{REF} = 3.3 V; VD+ = 3.3 V; Set VIH(\overline{EN}) = 0 V; Sweep VIH from 0 V to 1.4 V; Measure when D+ drops low (less than or equal to 5% of 3.3 V) from 3.3 V	1.2			V
	Low-level input voltage		Mode 0. Connect VPWR = 5 V; V _{REF} = 3.3 V; VD+ = 3.3 V. Set VIH(\overline{EN}) = 3.3 V; Sweep VIH from 3.3 V to 0.5 V; Measure when D+ rise to 95% of 3.3 V from 0 V			0.8	
I _{IL}	Input leakage current	\overline{EN}	Mode 0. VPWR = 5 V; V _{REF} = 3.3 V; VI (\overline{EN}) = 3.3 V; Measure current into EN pin			1	μ A
V _{OL}	Low-level output voltage	\overline{FLT}	Mode 0. Drive the TPS2S703-Q1 in OVP to assert FLT pin. Source I _{OL} = 1 mA into FLT pin and measure voltage on FLT pin when asserted			0.4	V
T _{SD_RISING}	The rising over-temperature protection shutdown threshold		VPWR = 5 V, ENZ = 0 V, T _A stepped up until FLTZ is asserted	140	150	165	$^{\circ}$ C
T _{SD_FALLING}	The falling over-temperature protection shutdown threshold		VPWR = 5 V, ENZ = 0 V, T _A stepped down from T _{SD_RISING} until FLTZ is cleared	125	138	150	$^{\circ}$ C
T _{SD_HYST}	The over-temperature protection shutdown threshold hysteresis		T _{SD_RISING} – T _{SD_FALLING}	10	12	15	$^{\circ}$ C
OVP CIRCUIT—VD\pm							
V _{OVP_RISING}	Input overvoltage protection threshold, V _{REF} > 3.6 V	VD \pm	Mode 1. Set V _{PWR} = 5 V; $\overline{EN} = 0$ V; R _{TOP} = 165 k Ω , R _{BOT} = 24.9 k Ω . Connect D \pm to 40- Ω load. Increase VD+ or VD- from 4.1 V to 4.9 V. Measure the value at which FLTZ is asserted	4.3	4.5	4.7	V
V _{OVP_RISING}	Input overvoltage protection threshold	VD \pm	Mode 1. Set V _{PWR} = 5 V; $\overline{EN} = 0$ V; R _{TOP} = 140 k Ω , R _{BOT} = 24.9 k Ω . Increase VD+ or VD- from 3.6 V to 4.6 V. Measure the value at which FLTZ is asserted. Repeat for R _{TOP} = 39 k Ω , R _{BOT} = 150 k Ω . Increase VD+ or VD- from 0.6 V to 0.9 V. Measure the value at which FLTZ is asserted. See the resultant values meet the equation, and make sure to observe data switches turnoff. Also check for mode 0 when V _{REF} = 3.3 V	1.19 \times V _{REF}	1.25 \times V _{REF}	1.31 \times V _{REF}	V
V _{HYS_OVP}	Hysteresis on OVP	VD \pm	Difference between rising and falling OVP thresholds on VD \pm		25		mV
V _{OVP_FALLING}	Input overvoltage protection threshold	VD \pm	After collecting each rising OVP threshold, lower the VD \pm voltage until you see \overline{FLT} deassert. This gives the falling OVP threshold. Use this value to calculate V _{HYS_OVP}		VOV P_RI SING – VHYS _OVP		V
I _{VD_LEAK_0 V}	Leakage current on VD \pm during normal operation	VD \pm	Standard mode 0 or mode 1. Set VD \pm = 0 V. D \pm = floating. Measure current flowing into VD \pm	-0.1		0.1	μ A

Electrical Characteristics (continued)

over operating free-air temperature range (unless otherwise noted)

PARAMETER		TEST CONDITIONS		MIN	TYP	MAX	UNIT
$I_{VD_LEAK_3.6V}$	Leakage current on $VD\pm$ during normal operation	$VD\pm$	Standard mode 0 or mode 1. Set $VD\pm = 3.6$ V. $D\pm =$ floating. Measure current flowing into $VD\pm$		2.5	4	μA
$V_{OVP_3.3V}$	Input overvoltage threshold for $V_{REF} = 3.3$ V	$VD\pm$	Standard mode 1. $R_{TOP} = 140$ k $\Omega \pm 1\%$, $R_{BOT} = 24.9$ k $\Omega \pm 1\%$. Connect $D\pm$ to 40- Ω load. Measure the value at which FLTZ is asserted	3.61	4.14	4.67	V
$V_{OVP_0.66V}$	Input overvoltage threshold for $V_{REF} = 0.66$ V	$VD\pm$	Standard mode 1. $R_{TOP} = 47.5$ k $\Omega \pm 1\%$, $R_{BOT} = 150$ k $\Omega \pm 1\%$. Connect $D\pm$ to 40- Ω load. Measure the value at which FLTZ is asserted	0.72	0.83	0.94	V
SHORT-TO-BATTERY							
V_{DATA_STB}	Data line hotplug short-to-battery tolerance	$V\pm$	Charge battery-equivalent capacitor to test voltage then discharge to pin under test through a 1 meter, 18-ga wire. (See Figure 23 application information for more details)			18	V
$V_{CLAMP_STB_DP/M_3V3}$	Data line system side clamping voltage during STB	$D\pm$	Test both $D+$ and $D-$ FETs. Test $D+$ and $D-$ independently. Short $VD+$ and $VD-$ to 18 V via hotplug to a battery-equivalent capacitor with a 1 meter, 18-ga wire. $V_{REF} = 3.3$ V, $V_{PWR} = 5$ V. Test in standard mode 0 and mode 1		5.5	6	V
$V_{CLAMP_STB_DP/M_0V6}$	Data line system side clamping voltage during STB	$D\pm$	Test both $D+$ and $D-$ FETs. Short $VD+$ and $VD-$ to 18 V via hotplug to a battery-equivalent capacitor with a 1 meter, 18-ga wire. $V_{REF} = 0.63$ V, $V_{PWR} = 5$ V. Test in standard mode 0 and mode 1		3.2	3.5	V
DATA LINE SWITCHES – $VD+$ to $D+$ or $VD-$ to $D-$							
R_{ON}	On resistance		Mode 0 or 1. Set $V_{PWR} = 5$ V; $V_{REF} = 3.3$ V; $\overline{EN} = 0$ V; Measure resistance between $D+$ and $VD+$ or $D-$ and $VD-$, voltage between 0 and 0.4 V		4	6.5	Ω
$R_{ON(Flat)}$	On resistance flatness		Mode 0 or 1. Set $V_{PWR} = 5$ V; $V_{REF} = 3.3$ V; $\overline{EN} = 0$ V; Measure resistance between $D+$ and $VD+$ or $D-$ and $VD-$, sweep voltage between 0 and 0.4 V. Take difference of resistance at 0.4-V and 0-V $VD\pm$ bias			1	Ω
BW_{ON}	On bandwidth (–3-dB)		Mode 0 or 1. Set $V_{PWR} = 5$ V; $V_{REF} = 3.3$ V; $\overline{EN} = 0$ V; Measure S21 bandwidth from $D+$ to $VD+$ or $D-$ to $VD-$ with voltage swing = 400 mVpp, $V_{cm} = 0.2$ V		960		MHz

6.8 Power Supply and Supply Current Consumption Characteristics

over operating free-air temperature range (unless otherwise noted)

PARAMETER		TEST CONDITIONS	MIN	TYP	MAX	UNIT
$V_{UVLO_RISING_VPWR}$	V_{PWR} rising UVLO threshold	Use standard mode 0 set-up. Set $\overline{EN} = 0$ V, load D+ to 45 Ω , $VD+ = 3.3$ V. Set $V_{PWR} = 3.5$ V, and step up V_{PWR} until 90% of $VD+$ appears on D+	3.7	3.95	4.2	V
$V_{UVLO_HYST_VPWR}$	V_{PWR} UVLO hysteresis	Use standard mode 0 set up. Set $\overline{EN} = 0$ V, load D+ to 45 Ω , $VD+ = 3.3$ V. Set $V_{PWR} = 4.3$ V, and step down V_{PWR} until D+ falls to 10% of $VD+$. This gives $V_{UVLO_FALLING_VPWR} - V_{UVLO_RISING_VPWR} - V_{UVLO_FALLING_VPWR} = V_{UVLO_HYST_VPWR}$ for this unit	250	300	400	mV
$V_{UVLO_RISING_VREF}$	VREF rising UVLO threshold in mode 0	Use standard mode 0 set up. Set $\overline{EN} = 0$ V, load D+ to 45 Ω , $VD+ = 3.3$ V. Set $VREF = 2.5$ V, and step up VREF until 90% of $VD+$ appears on D+	2.6	2.7	2.9	V
$V_{UVLO_HYST_VREF}$	VREF UVLO hysteresis	Use standard mode 0 set up. Set $\overline{EN} = 0$ V, load D+ to 45 Ω , $VD+ = 3.3$ V. Set $VREF = 3$ V, and step down VREF until D+ falls to 10% of $VD+$. This gives $V_{UVLO_FALLING_VREF} - V_{UVLO_RISING_VREF} - V_{UVLO_FALLING_VREF} = V_{UVLO_HYST_VREF}$ for this unit	75	125	200	mV
$I_{VPWR_DISABLE_D_MODE0}$	V_{PWR} disabled current consumption	Use standard mode 0. $\overline{EN} = 5$ V. Measure current into V_{PWR}			110	μ A
$I_{VPWR_DISABLE_D_MODE1}$	V_{PWR} disabled current consumption	Use standard mode 1. $\overline{EN} = 5$ V. Measure current into V_{PWR}			110	μ A
$I_{VREF_DISABLE_D}$	VREF disabled current consumption mode 0	Use standard mode 0. $\overline{EN} = 5$ V. Measure current into VREF			10	μ A
I_{VPWR_MODE0}	V_{PWR} operating current consumption	Use standard mode 0. $\overline{EN} = 0$ V. Measure current into V_{PWR}			250	μ A
I_{VPWR_MODE1}	V_{PWR} operating current consumption	Use standard mode 1. $\overline{EN} = 0$ V. Measure current into V_{PWR}			350	μ A
I_{VREF}	VREF operating current consumption mode 0	Use standard mode 0. $\overline{EN} = 0$ V. Measure current into V_{REF}		12	20	μ A
I_{CHG_VREF}	VREF fast charge current	Standard mode 1. $0.1 \mu F < C_{VREF} < 3 \mu F$. Set-up for charging to 3.3 V. Use a high voltage capacitor that does not derate capacitance up the 3.3 V. Measure slope to calculate the current when C_{VREF} cap is being charged. Test to check this OPEN LOOP method		22		mA
$I_{D_OFF_LEAK_STB}$		Mode 0. Measured flowing into D+ or D- supply, $V_{PWR} = 0$ V, $VD+$ or $VD- = 18$ V, $\overline{EN} = 0$ V, $V_{REF} = 0$ V, $D\pm = 0$ V	-1		1	μ A
$I_{D_ON_LEAK_STB}$		Mode 0. Measured flowing into D+ or D- supply, $V_{PWR} = 5$ V, $VD+$ or $VD- = 18$ V, $\overline{EN} = 0$ V, $V_{REF} = 3.3$ V, $D\pm = 0$ V	-1		1	μ A
$I_{VD_OFF_LEAK_STB}$		Mode 0. Measured flowing out of $VD+$ or $VD-$ supply, $V_{PWR} = 0$ V, $VD+$ or $VD- = 18$ V, $\overline{EN} = 0$ V, $V_{REF} = 0$ V, $D\pm = 0$ V			120	μ A
$I_{VD_ON_LEAK_STB}$		Mode 0. Measured flowing out of $VD+$ or $VD-$ supply, $V_{PWR} = 5$ V, $VD+$ or $VD- = 18$ V, $\overline{EN} = 0$ V, $V_{REF} = 3.3$ V, $D\pm = 0$ V			120	μ A
$I_{VPWR_TO_VREF_LEAK}$	Leakage from V_{PWR} to VREF	Use standard mode 0. Set $VREF = 0$ V. Measured current flowing out of VREF pin			1	μ A
$I_{VREF_TO_VPWR_LEAK}$	Leakage from VREF to V_{PWR}	Use standard mode 0. Set $V_{PWR} = 0$ V. Measured as current flowing out of V_{PWR} pin			1	μ A

6.9 Timing Requirements

over operating free-air temperature range (unless otherwise noted)

		MIN	NOM	MAX	UNIT
ENABLE PIN AND VREF FAST CHARGE					
T_{VREF_CHG}	VREF fast charge time		0.5	1	ms
		Time between when 5 V is applied to V_{PWR} , and V_{REF} reaches $V_{VREF_FAST_CHG}$. Needs to happen before or at same time $t_{ON_STARTUP}$ completes			

Timing Requirements (continued)

over operating free-air temperature range (unless otherwise noted)

			MIN	NOM	MAX	UNIT
$T_{ON_STARTUP_MODE0}$	Device turnon time from UVLO mode 0	Mode 0. $\overline{EN} = 0$ V, measured from V_{PWR} and $V_{REF} = UVLO^+$ to data FET ON, V_{PWR} comes to $UVLO^+$ second. Place 3.3 V on VD_{\pm} . Ramp V_{REF} to 3.3 V, then V_{PWR} to 5 V and measure the time it takes for D_{\pm} to reach 90% of VD_{\pm}		0.5	1	ms
$T_{ON_STARTUP_MODE1}$	Device turnon time from UVLO mode 1	Informative. mode 1. $\overline{EN} = 0$ V, measured from $V_{PWR} = UVLO^+$ to data FET ON		$0.5 + T_{CHG_C_VREF}$		ms
$T_{ON_STARTUP_MODE1_3.3V}$	Device turnon time from UVLO mode 1	Mode 1. $\overline{EN} = 0$ V, measured from $V_{PWR} = UVLO^+$ to data FET ON, $C_{VREF} = 1 \mu F$, $V_{REF_FINAL} = 3.3$ V. Measure the time it takes for D_{\pm} to reach 90% of VD_{\pm}		0.6	1	ms
$T_{ON_EN_MODE0}$	Device turnon time mode 0	Mode 0. $V_{PWR} = 5$ V, $V_{REF} = 3.3$ V, time from \overline{EN} is asserted until data FET is ON. Place 3.3 V on VD_{\pm} , measure the time it takes for D_{\pm} to reach 90% of VD_{\pm}		150		μs
$T_{ON_EN_MODE1}$	Device turnon time mode 1	Mode 1. $V_{PWR} = 5$ V, $V_{REF_INITIAL} = 0$ V, time from \overline{EN} is asserted until data FET is ON. Place 3.3 V on VD_{\pm} , measure the time it takes for D_{\pm} to reach 90% of VD_{\pm}		$150 + T_{CHG_V_REF}$		μs
$T_{ON_EN_MODE1_3.3V}$	Device turnon time mode 1 for $V_{REF} = 3.3$ V	Mode 1. $V_{PWR} = 5$ V, $V_{REF_INITIAL} = 0$ V, time from \overline{EN} is asserted until data FET is ON. Place 3.3 V on VD_{\pm} , measure the time it takes for D_{\pm} to reach 90% of VD_{\pm} . $C_{VREF} = 1 \mu F$, $V_{REF_FINAL} = 3.3$ V		300		μs
T_{OFF_EN}	Device turnoff time	Mode 0 or 1. $V_{PWR} = 5$ V, $V_{REF} = 3.3$ V, time from \overline{EN} is deasserted until data FET is off. Place 3.3 V on VD_{\pm} , measure the time it takes for D_{\pm} to fall to 10% of VD_{\pm} , $R_{D_{\pm}} = 45 \Omega$		5		μs
T_{CHG_CVREF}	Time to charge C_{VREF}	Informative. Mode 1. Time from $V_{REF} = 0$ V to $80\% \times V_{REF_FINAL}$ after \overline{EN} transitions from high to low		$(C_{VREF} \times 0.8 (V_{REF_FINAL} / (I_{C_HG_VREF}))$		s
$T_{CHG_CVREF_3.3V}$	Time to charge C_{VREF} to 3.3 V	Mode 1. Time from $V_{REF} = 0$ V to $90\% \times 3.3$ V after \overline{EN} transitions from high to low, $C_{VREF} = 1 \mu F$		132		μs
$T_{CHG_CVREF_0.66V}$	Time to charge C_{VREF} to 0.66 V	Mode 1. Time from $V_{REF} = 0$ V to $90\% \times 0.63$ V after \overline{EN} transitions from high to low, $C_{VREF} = 1 \mu F$. $R_{TOP} = 47.5 k\Omega \pm 1\%$, $R_{BOT} = 150 k\Omega \pm 1\%$		26		μs
OVER VOLTAGE PROTECTION						
$t_{OVP_response_VBUS}$	OVP response time to VBUS	Mode 0 or 1. Measured from OVP condition to FET turn off. Short VD_{\pm} to 5 V and measure the time it takes D_{\pm} voltage to reach $0.1 \times V_{D_{\pm_CLAMP_MAX}}$ from the time the 5-V hot-plug is applied. $R_{LOAD_D_{\pm}} = 45 \Omega$. ^{(1) (2)}		2		μs
$t_{OVP_response}$	OVP response time	Mode 0 or 1. Measured from OVP condition to FET turn off. Short VD_{\pm} to 18 V and measure the time it takes D_{\pm} voltage to reach $0.1 \times V_{D_{\pm_CLAMP_MAX}}$ from the time the 18-V hot-plug is applied. $R_{LOAD_D_{\pm}} = 45 \Omega$. ^{(1) (2)}		0.1	1	μs
$t_{OVP_Recov_FLT}$	Recovery time \overline{FLT} pin	Measured from OVP clear to \overline{FLT} deassertion ⁽¹⁾		32		ms
$t_{OVP_Recov_FET}$	Recovery time for data FET to turn back on	Measured from OVP clear until FET turns back on. Drop VD_+ from 16 V to 3.3 V with $V_{REF} = 3.3$ V, measure time it takes for D_+ to reach 90% of 3.3 V		32		ms
t_{OVP_ASSERT}	\overline{FLT} assertion time	Measured from OVP on VD_+ or VD_- to \overline{FLT} assertion	12.6	18	23.4	ms

(1) Shown in [Figure 1](#).

(2) Specified by design, not production tested.

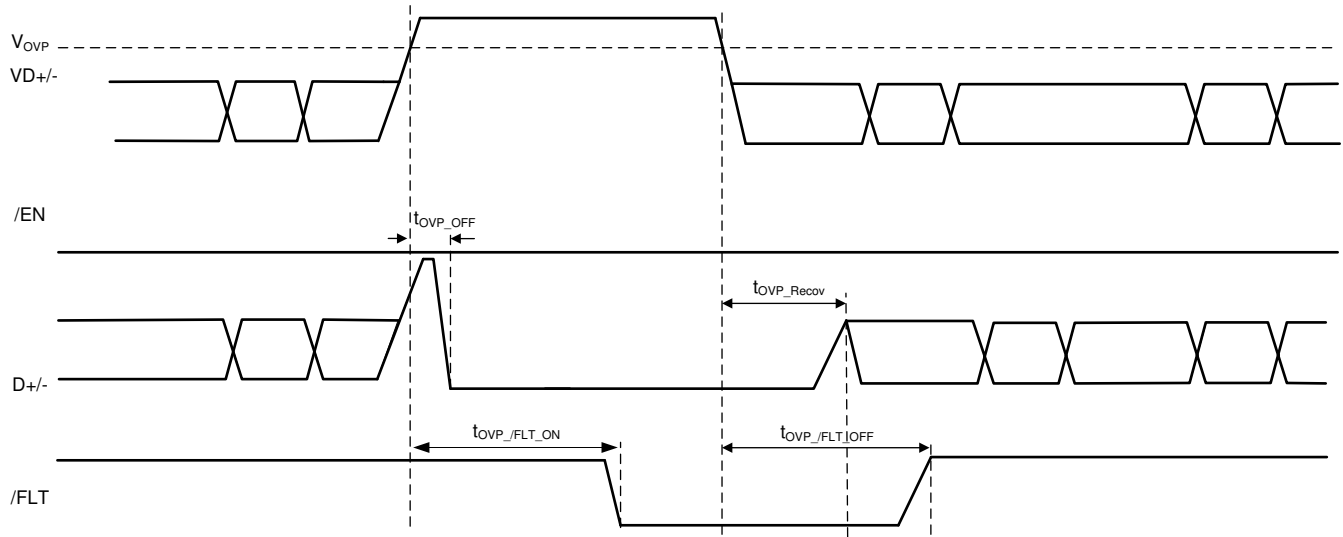

(1) OVP Operation – VD_{+} , VD_{-}

Figure 1. TPD2S703-Q1 Timing Diagram

6.10 Typical Characteristics

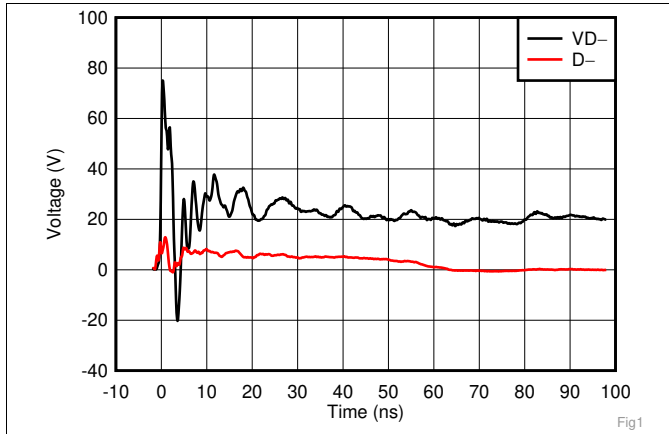

Figure 2. 8-kV IEC 61400-4-2 Contact Waveform

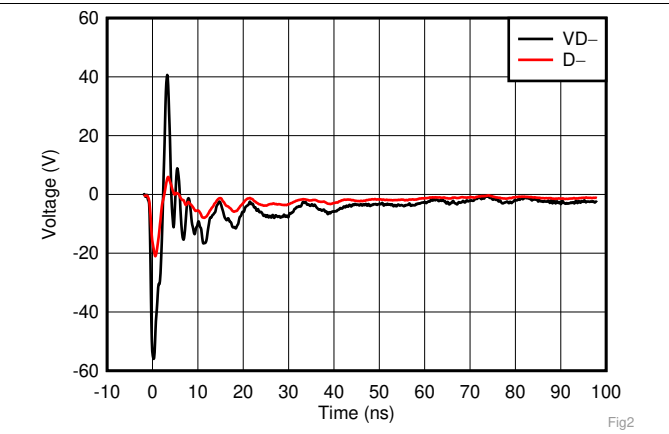

Figure 3. -8-kV IEC 61400-4-2 Contact Waveform

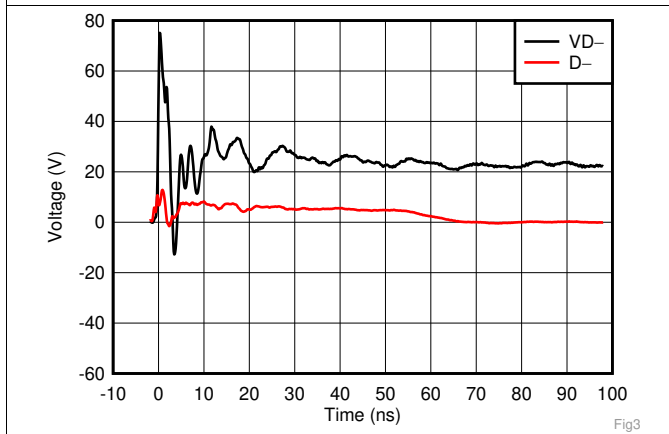

Figure 4. 8-kV ISO 10605 (330-pF, 330-Ω) Contact Waveform

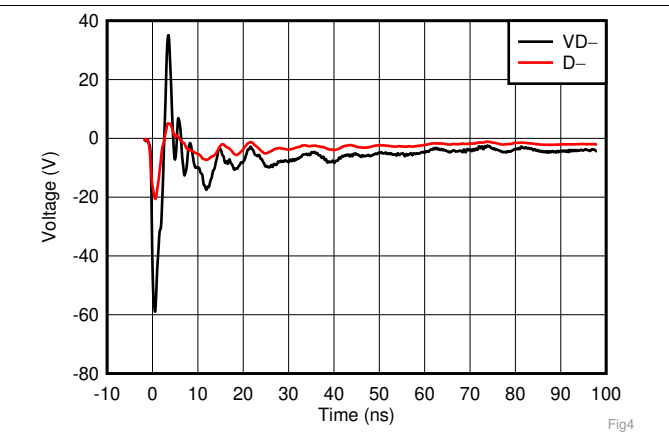

Figure 5. -8-kV ISO 10605 (330-pF, 330-Ω) Contact Waveform

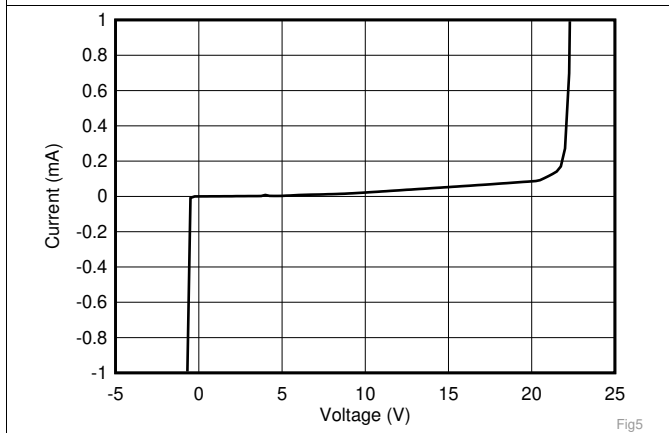

Figure 6. Data Line I-V Curve

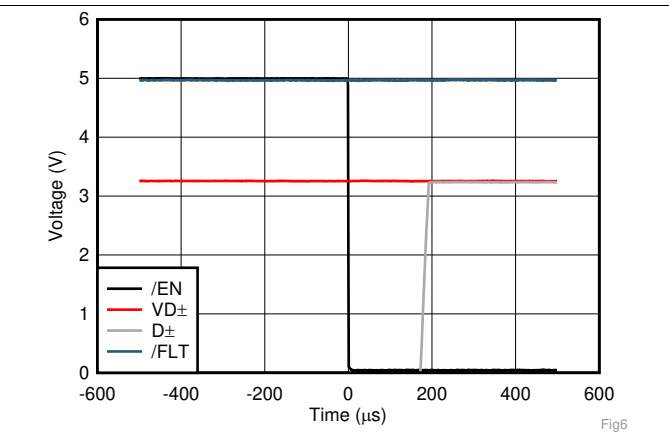

Figure 7. Data Switch Turnon Time

Typical Characteristics (continued)

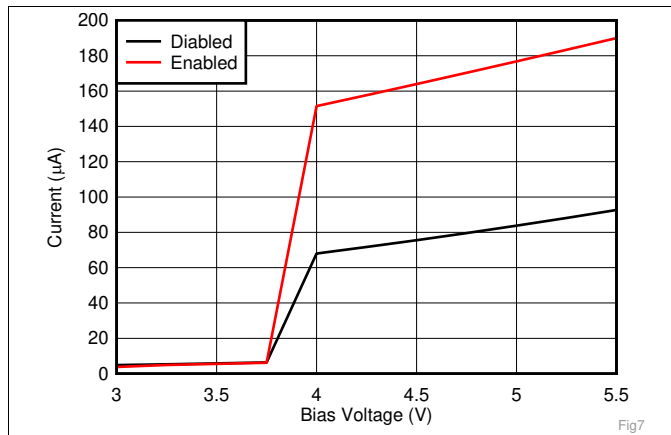

Figure 8. V_{PWR} Operating Current vs Bias Voltage

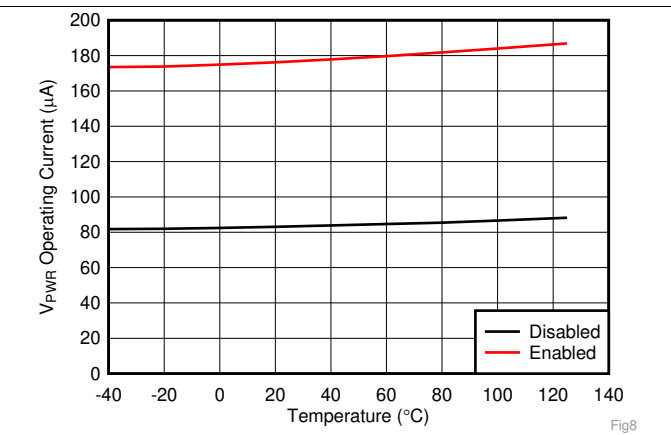

Figure 9. V_{PWR} Operating Current vs Temperature ($V_{PWR} = 5\text{ V}$)

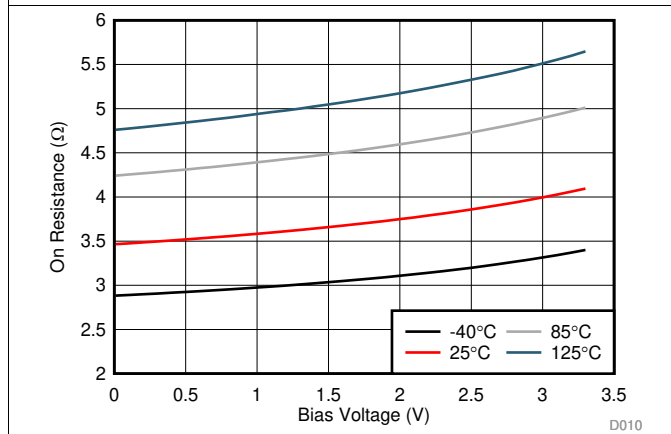

Figure 10. $V_{D\pm}$ Leakage Current at 18 V Across Temperature (Enabled)

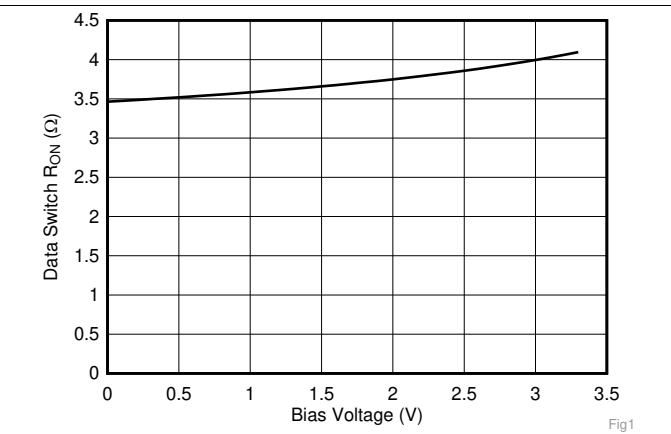

Figure 11. Data Switch R_{ON} vs Bias Voltage

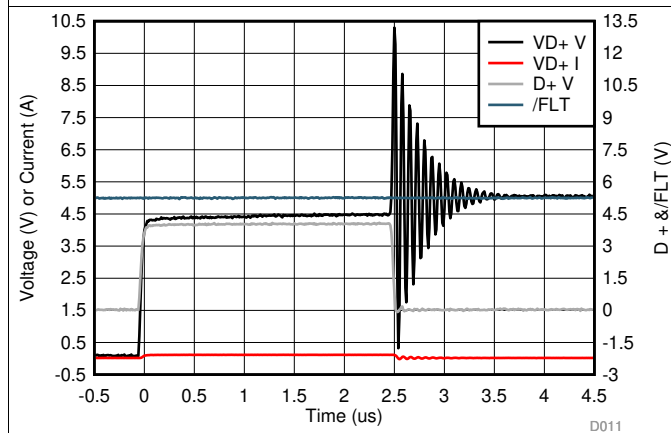

Figure 12. Data Switch Short-to-5 V Response Waveform

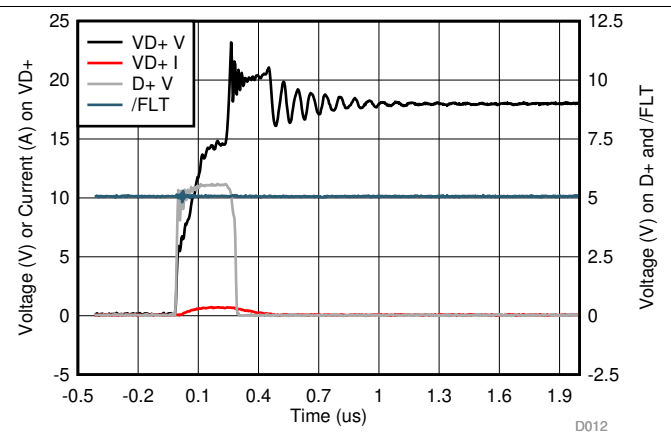

Figure 13. Data Switch Short-to-18 V Response Waveform

Typical Characteristics (continued)

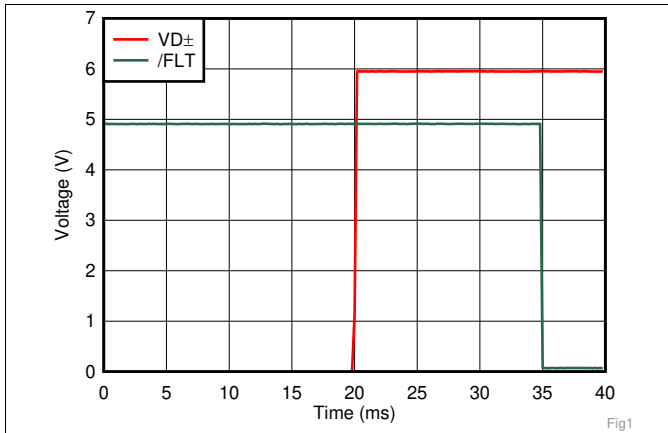

Figure 14. FLT Assertion Time During OVP

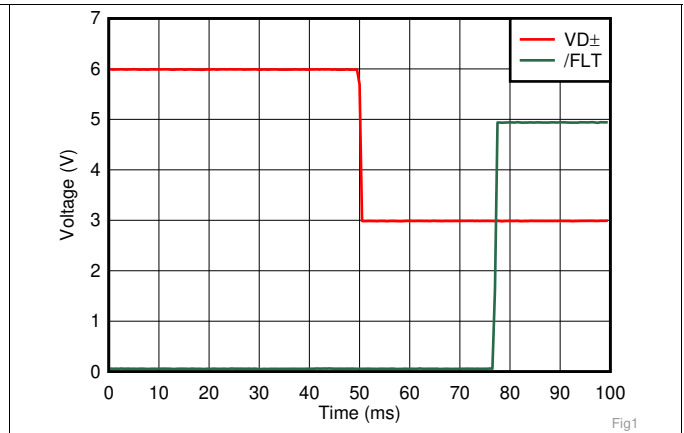

Figure 15. FLT Recover Time After OVP Clear

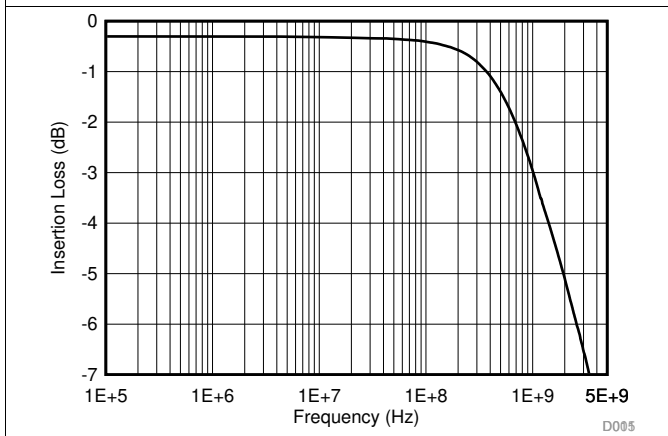

Figure 16. Data Switch Differential Bandwidth

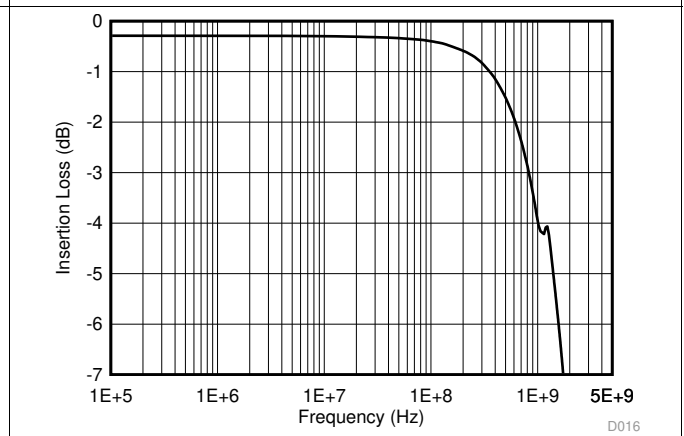

Figure 17. Data Switch Single-Ended Bandwidth

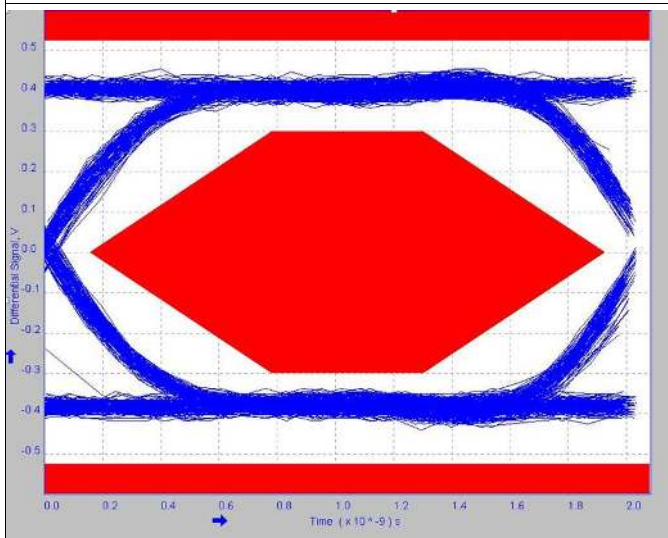

Figure 18. USB2.0 Eye Diagram (No TPD2S703-Q1)

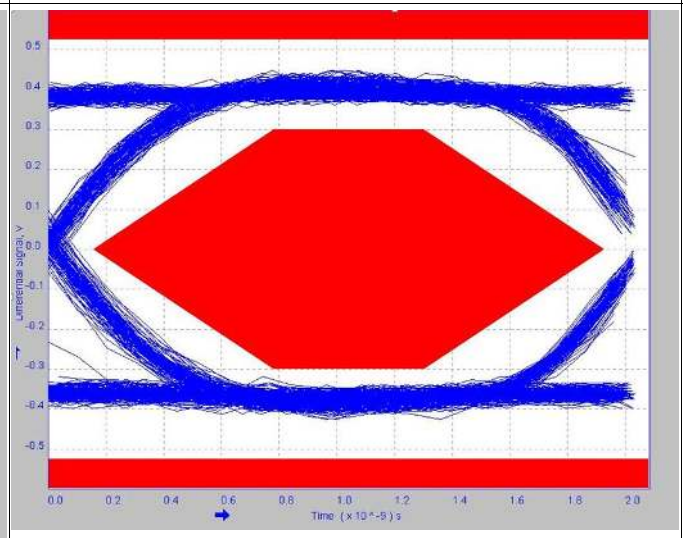
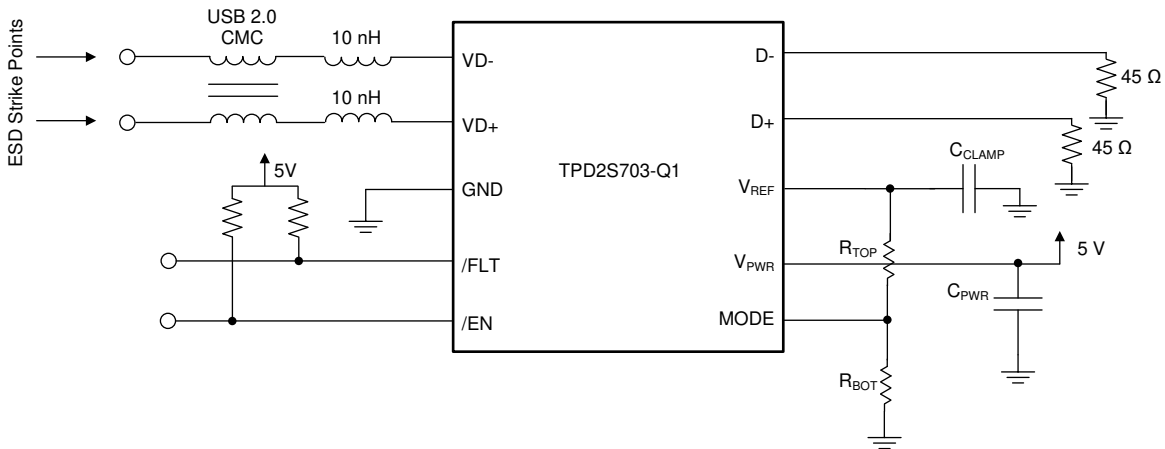

Figure 19. USB2.0 Eye Diagram (With TPD2S703-Q1)

7 Parameter Measurement Information



Copyright © 2017, Texas Instruments Incorporated

Figure 20. ESD Setup

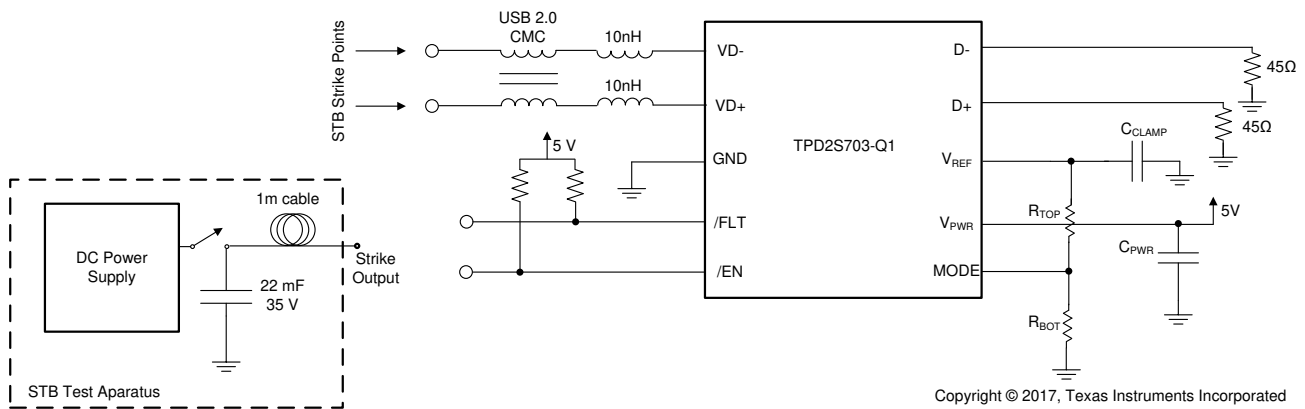

Copyright © 2017, Texas Instruments Incorporated

Figure 21. Short-to-Battery Setup

8 Detailed Description

8.1 Overview

The TPD2S703-Q1 is a 2-Channel Data Line Short-to-Battery, Short-to- V_{BUS} , and IEC61000-4-2 ESD protection device for automotive high-speed interfaces like USB2.0. The TPD2S703-Q1 contains two data line nFET switches which ensure safe data communication while protecting the internal system circuits from any overvoltage conditions at the $VD+$ and $VD-$ pins. On these pins, this device can handle overvoltage protection up to 18-V DC. This provides sufficient protection for shorting the data lines to the car battery as well as the USB V_{BUS} rail.

Additionally, the TPD2S703-Q1 has a \overline{FLT} pin which provides an indication when the device sees an overvoltage condition and automatically resets when the overvoltage condition is removed. The TPD2S703-Q1 also integrates IEC ESD clamps on the $VD+$ and $VD-$ pins, thus eliminating the need for external TVS clamp circuits in the application.

The TPD2S703-Q1 has an internal oscillator and charge pump that controls the turnon of the internal nFET switches. The internal oscillator controls the timers that enable the charge pump and resets the open-drain \overline{FLT} output. If $VD+$ and $VD-$ are less than V_{OVP} , the internal charge pump is enabled. After an internal delay, the charge-pump starts-up, turning on the internal nFET switches. At any time, if $VD+$ or $VD-$ rises above V_{OVP} , TPD2S703-Q1 asserts \overline{FLT} pin LOW and the nFET switches are turned off.

8.2 Functional Block Diagram

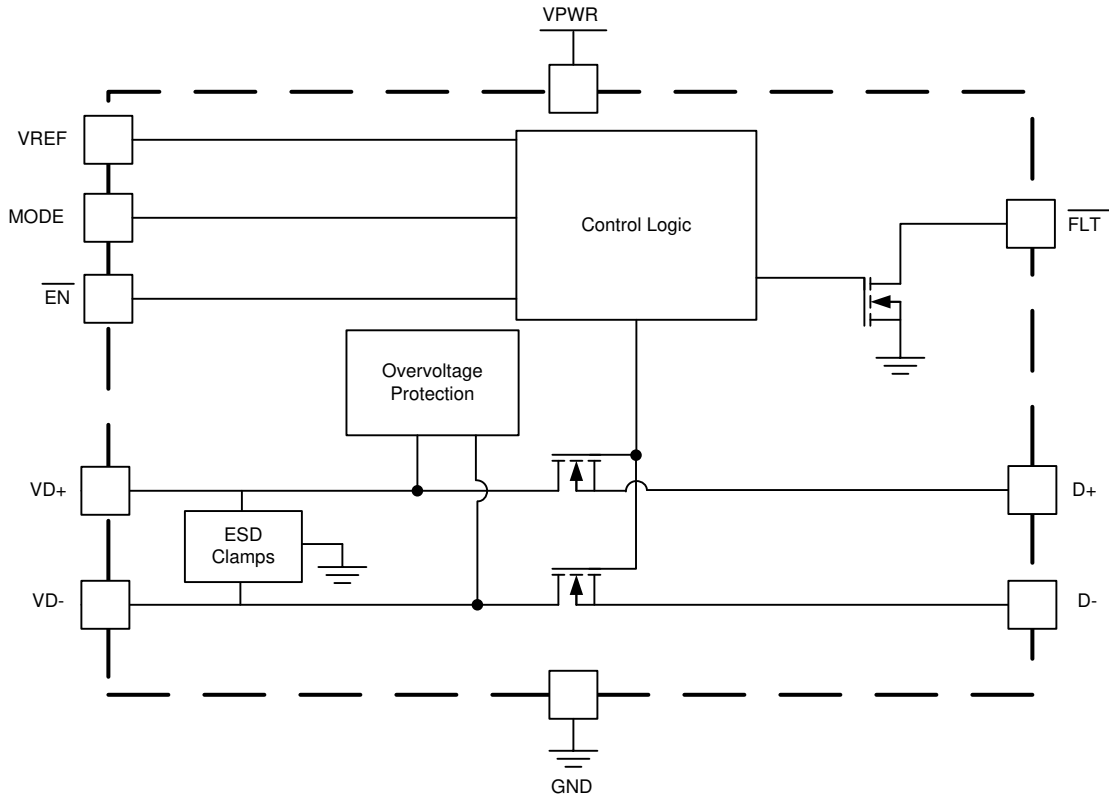

Copyright © 2017, Texas Instruments Incorporated

8.3 Feature Description

8.3.1 OVP Operation

When the V_{D+} , or V_{D-} voltages rise above V_{OVP} , the internal nFET switches are turned off, protecting the transceiver from overvoltage conditions. The response is very rapid, with the FET switches turning off in less than 1 μ s. Before the OVP condition, the \overline{FLT} pin is High-Z, and is pulled HIGH via an external resistor to indicate there is no fault. Once the OVP condition occurs, the \overline{FLT} pin is asserted LOW. When the V_{D+} , or V_{D-} voltages returns below $V_{OVP} - V_{HYS-OVP}$, the nFET switches are turned on again. When the OVP condition is cleared and the nFETs are completely turned on, the \overline{FLT} is reset to high-Z.

8.3.2 OVP Threshold

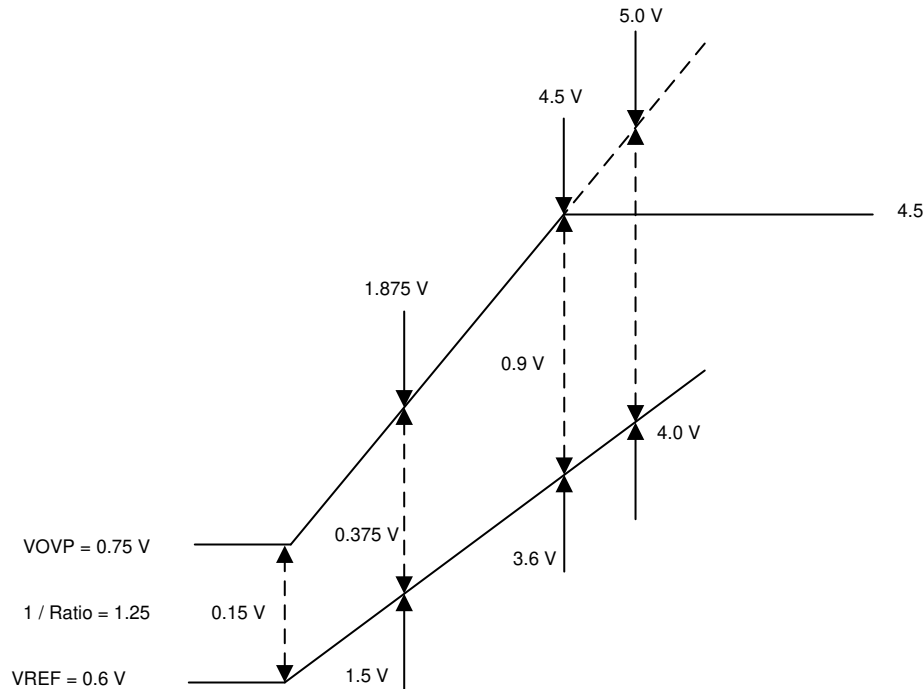

Figure 22. OVP Threshold

The OVP Threshold V_{OVP} is set by V_{REF} according to [Equation 1](#), [Equation 2](#) and [Equation 3](#).

$$V_{OVP} = 1.25 \times V_{REF} \quad (1)$$

$$V_{REF} \leq 3.6 \text{ V} \quad (2)$$

$$V_{OVP} = 4.5 \text{ V for } V_{REF} > 3.6 \text{ V} \quad (3)$$

[Equation 1](#), [Equation 2](#) and [Equation 3](#) yield the typical V_{OVP} values. See the parametric tables for the minimum and maximum values that include variation over temperature and process. [Figure 22](#) gives a graphical representation of the relationship between V_{OVP} and V_{REF} .

V_{REF} can be set either by an external regulator (Mode 0) or an internal adjustable regulator (Mode 1). See the [V_{REF} Operation](#) section for more details on how to operate V_{REF} in Mode 0 and Mode 1.

8.3.3 D± Clamping Voltage

The TPD2S703-Q1 provides a differentiated device architecture which allows the system designer to control the clamping voltage the protected transceiver sees from the D+ and D– pins. This architecture allows the system designer to minimize the amount of stress the transceiver sees during Short-to-Battery and ESD events. The clamping voltage that appears on the D+ and D– lines during a short-to-battery or ESD event obeys [Equation 4](#).

$$V_{CLAMP_DP/M} = V_{REF} + V_{BR} + IR_{DYN} \quad (4)$$

Feature Description (continued)

Where V_{BR} approximately = 0.7 V, I_{RDYN} approximately = 1 V. By adjusting V_{REF} , the clamping voltage of the D+ and D– lines can be adjusted. As V_{REF} also controls the OVP threshold, take care to insure that the V_{REF} setting both satisfies the OVP threshold requirements while simultaneously optimizing system protection on the D+ and D– lines.

The size of the capacitor used on the V_{REF} pin also influences the clamping voltage as transient currents during Short-to-Battery and ESD events flow into the V_{REF} capacitor. This causes the V_{REF} voltage to increase, and likewise the clamping voltage on D± according to [Equation 4](#). The larger capacitor that is used, the better the clamping performance of the device is going to be. See the parametric tables for the clamping performance of the TPD2S703-Q1 with a 1- μ F capacitor.

8.4 Device Functional Modes

The TPD2S703-Q1 has two modes of operation which vary the way the VREF pin functions. In Mode 0, the VREF pin is connected to an external regulator which sets the voltage on the VREF pin. In Mode 1, the TPD2S703-Q1 uses an adjustable internal regulator to set the VREF voltage. Mode 1 enables the system designer to operate the TPD2S703-Q1 with a single power supply, and have the flexibility to easily set the VREF voltage to any voltage between 0.6 V and 3.8 V with two external resistors.

9 Application and Implementation

NOTE

Information in the following applications sections is not part of the TI component specification, and TI does not warrant its accuracy or completeness. TI's customers are responsible for determining suitability of components for their purposes. Customers should validate and test their design implementation to confirm system functionality.

9.1 Application Information

The TPD2S703-Q1 offers 2-channels of short-to-battery protection (up to 18-V DC), short-to-VBUS protection, and IEC ESD protection for automotive high speed interfaces such as USB 2.0. For the overvoltage protection (OVP), this device integrates N-channel FET's which quickly isolate (200 ns) the protected circuitry in the event of an overvoltage condition on the VD+ and VD- lines. With respect to the ESD protection, the TPD2S703-Q1 has an internal clamping diode on each data line (VD+ and VD-) which provides 8-kV contact ESD protection and 15-kV air-gap ESD protection. More details on the internal components of the TPD2S703-Q1 can be found in the [Overview](#) section.

The TPD2S703-Q1 also has the ability to vary the OVP threshold based on the configuration of the Mode pin and the voltage present on the VREF pin (0.6 V-4.5 V). This functionality is discussed in greater depth in the [OVP Threshold](#) section. Once the VREF threshold is crossed, a fault is detectable to the user through the FLT pin, where 5 V on the pin indicates no fault is detected, and 0 V-0.4 V represents a fault condition. [Figure 23](#) shows the TPD2S703-Q1 in a typical application, interfacing between the protected internal circuitry and the connector side, where ESD vulnerability is at its highest.

9.2 Typical Application

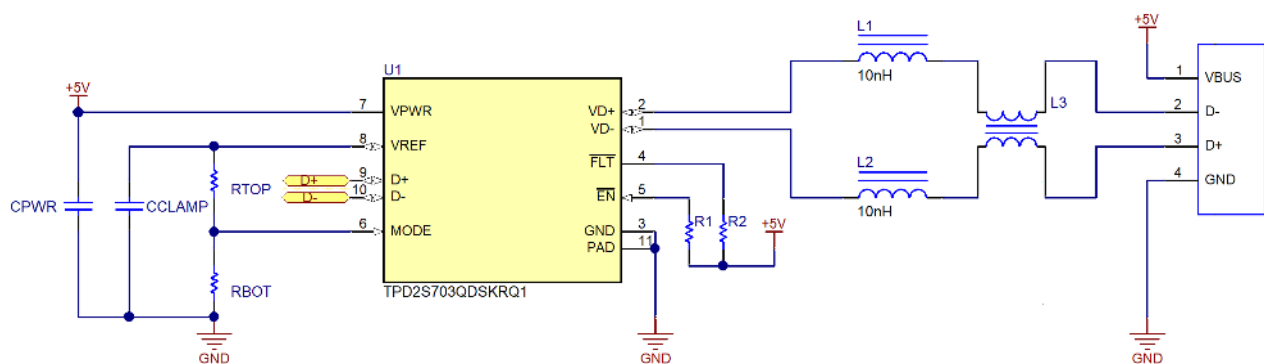

Figure 23. USB 2.0 Port With Short-to-Battery and IEC ESD Protection

Typical Application (continued)

9.2.1 Design Requirements

9.2.1.1 Device Operation

Table 1 gives the complete device functionality in response to the $\overline{\text{EN}}$ pin, to overvoltage conditions at the connector ($\text{VD}\pm$ pins), to thermal shutdown, and to the conditions of the V_{PWR} , V_{REF} , and MODE pins.

Table 1. Device Operation Table

Functional Mode	$\overline{\text{EN}}$	MODE	VREF	VPWR	VD±	TJ	$\overline{\text{FLT}}$	Comments
NORMAL OPERATION								
Mode 0 unpowered 1	X	$\text{R}_{\text{bot}} \leq 2.6 \text{ k}\Omega$	X	X	X	X	H	Device unpowered, data switches open
Mode 0 unpowered 2	X	$\text{R}_{\text{bot}} \leq 2.6 \text{ k}\Omega$	X	X	X	X	H	Device unpowered, data switches open
Mode 1 unpowered	X	$\text{R}_{\text{top}} \parallel \text{R}_{\text{bot}} > 14 \text{ k}\Omega$	X	X	X	X	H	Device unpowered, data switches open
Mode 0 disabled	H	$\text{R}_{\text{bot}} \leq 2.6 \text{ k}\Omega$	>UVLO	>UVLO	X	<TSD	H	Device disabled, data switches open
Mode 1 disabled	H	$\text{R}_{\text{top}} \parallel \text{R}_{\text{bot}} > 14 \text{ k}\Omega$	Set by R_{top} and R_{bot}	>UVLO	X	<TSD	H	Device disabled, data switches open, V_{REF} is disabled
Mode 0 enabled	L	$\text{R}_{\text{bot}} \leq 2.6 \text{ k}\Omega$	>UVLO	>UVLO	<OVP	<TSD	H	Device enabled, data switches closed, V_{REF} is the value set by the power supply on V_{REF}
Mode 1 enabled	L	$\text{R}_{\text{top}} \parallel \text{R}_{\text{bot}} > 14 \text{ k}\Omega$	Set by R_{top} and R_{bot}	>UVLO	<OVP	<TSD	H	Device enabled, data switches closed, V_{REF} is the value set by the R_{top} and R_{bot} resistor divider
FAULT CONDITIONS								
Mode 0 thermal shutdown	X	$\text{R}_{\text{bot}} \leq 2.6 \text{ k}\Omega$	X	>UVLO	X	>TSD	L	Thermal shutdown, data switches opened, $\overline{\text{FLT}}$ pin asserted
Mode 1 thermal shutdown	X	$\text{R}_{\text{top}} \parallel \text{R}_{\text{bot}} > 14 \text{ k}\Omega$	Set by R_{top} and R_{bot}	>UVLO	X	>TSD	L	Thermal shutdown, data switches opened, V_{REF} is disabled, $\overline{\text{FLT}}$ pin asserted
Mode 0 OVP fault	L	$\text{R}_{\text{bot}} \leq 2.6 \text{ k}\Omega$	>UVLO	>UVLO	>OVP	<TSD	L	Data line overvoltage protection mode. OVP is set relative to the voltage on V_{REF} . Data switches opened, $\overline{\text{FLT}}$ pin asserted
Mode 1 OVP fault	L	$\text{R}_{\text{top}} \parallel \text{R}_{\text{bot}} > 14 \text{ k}\Omega$	Set by R_{top} and R_{bot}	>UVLO	>OVP	<TSD	L	Data line overvoltage protection mode. OVP is set relative to the voltage on V_{REF} . Data switches opened, fault pin asserted

9.2.2 Detailed Design Procedure

9.2.2.1 Common choke and Inductor for $\text{VD}+$ and $\text{VD}-$

The TPD2S703-Q1 ESD system setup need to add the common choke and inductor in $\text{VD}+$ and $\text{VD}-$, it recommend to choose the impedance equal to 90Ohm@100Mhz common choke and 10nH inductor for this setup.

9.2.2.2 V_{REF} Operation

The TPD2S703-Q1 has two modes of operation which vary the way the V_{REF} pin functions. In Mode 0, the V_{REF} pin is connected to an external regulator which sets the voltage on the V_{REF} pin. In Mode 1, the TPD2S703-Q1 uses an adjustable internal regulator to set the V_{REF} voltage. Mode 1 enables the system designer to operate the TPD2S703-Q1 with a single power supply, and have the flexibility to easily set the V_{REF} voltage to any voltage between 0.6 V and 3.8 V with two external resistors.

9.2.2.2.1 Mode 0

To set the device into Mode 0, ensure that R_{bot} , resistance between the MODE pin and ground, is less than 2.6 k Ω . The easiest way to implement Mode 0 is to directly connect the mode pin to GND on your PCB. With this resistance condition met, connect V_{REF} to an external regulator to set the V_{REF} voltage.

9.2.2.2.2 Mode 1

To operate in Mode 1, ensure that $R_{top} \parallel R_{bot}$, resistance between the MODE pin and ground, is greater than 14 k Ω . This is accomplished by insuring $R_{top} \parallel R_{bot} > 14$ k Ω because when the device is initially powered up, V_{REF} is at ground until the internal circuitry recognizes if the device is in Mode 1 or Mode 2.

In Mode 1, V_{REF} is set by using an internal regulator to set the voltage. Using a resistor divider off of a feedback comparator is how to set V_{REF} , similar to a standard LDO or DC/DC. V_{REF} is set in Mode 1 according to [Equation 5](#).

$$V_{REF} = \frac{V_{MODE}(R_{TOP} + R_{BOT})}{R_{BOT}} \quad (5)$$

[Equation 5](#) yields the typical value for V_{REF} . When using $\pm 1\%$ resistors R_{TOP} and R_{BOT} , V_{REF} accuracy is going to be $\pm 5\%$. Therefore, the minimum and maximum values for V_{REF} can be calculated off of the typical V_{REF} . The parametric tables above give example R_{TOP} and R_{BOT} resistors to use for standard output V_{REF} voltages for Mode 1.

9.2.2.3 Mode 1 Enable Timing

In Mode 1, when the TPD2S703-Q1 is disabled, the output regulator is disabled, leading V_{REF} to discharge to 0 V through R_{TOP} and R_{BOT} . It is desired for V_{REF} to be at 0 V when the device is disabled to minimize the clamping voltage during a power disabled Short-to-Battery or ESD event. If V_{REF} is at 0 V, this holds D_{\pm} near ground during these fault events.

When enabling the TPD2S703-Q1, V_{REF} is quickly charged up to insure a quick turnon time of the Data FETs. Data FET turnon is gated by V_{REF} reaching 80% of its final voltage plus 150 μ s to insure a proper OVP threshold is set before passing data. This prevents false OVPs due to normal operation. Because Data FET turnon is gated by charging the V_{REF} clamping capacitor, the size of the capacitor influences the turnon time of the Data switches. The TPD2S703-Q1's internal regulator uses a constant current source to quickly charge the V_{REF} clamping capacitor, so the charging time of C_{VREF} can easily be calculated with [Equation 6](#).

$$t_{CHG_CVREF} = \frac{C_{VREF} \times 0.8 (V_{REF_FINAL})}{I_{CHG_VREF}} \quad (6)$$

Where C_{VREF} is the clamping capacitance on V_{REF} , V_{REF_FINAL} is the final value V_{REF} is set to, and $I_{CHG_VREF} = 22$ mA (typical). If $V_{REF} = 1$ V, 0.8 is used in the above equation because 80% of V_{REF} is the amount of time that gates the turnon of the Data FETs. Once t_{CHG_CVREF} is calculated, the typical turnon time of the Data FETs can be calculated from [Equation 7](#).

$$t_{ON_EN_MODE1} = t_{CHG_CVREF} + 150 \mu s \quad (7)$$

9.2.3 Application Curves

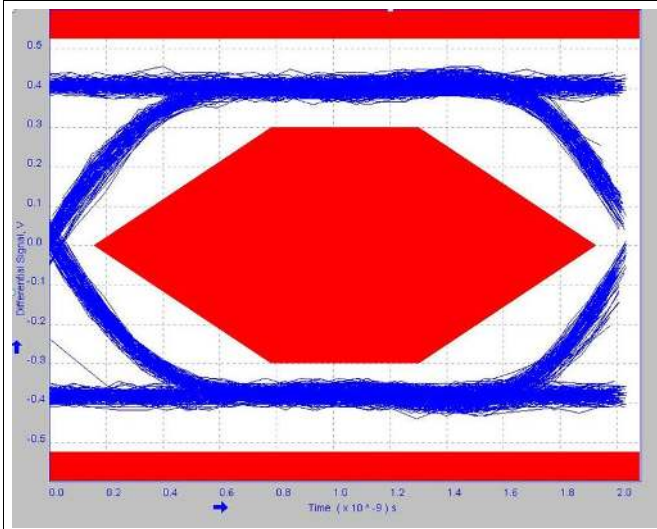

Figure 24. USB2.0 Eye Diagram (Board Only, Through Path)

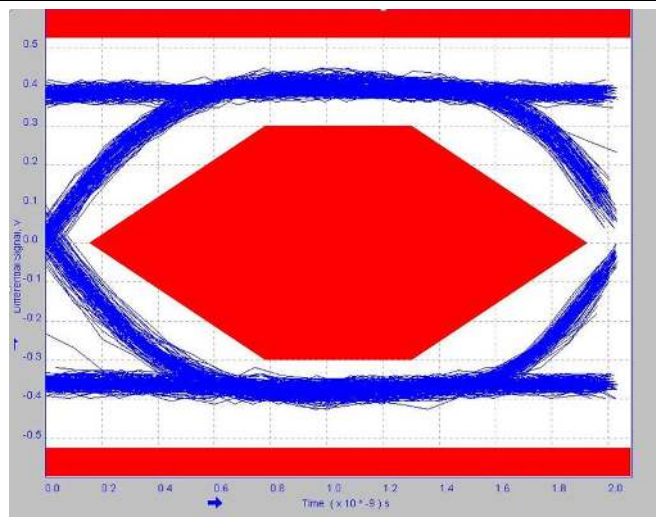

Figure 25. USB2.0 Eye Diagram (System from Typical Application Schematic)

10 Power Supply Recommendations

10.1 V_{PWR} Path

The V_{PWR} pin provides power to the TPD2S703-Q1. A 10- μ F capacitor is recommended on V_{PWR} as close to the pin as possible for localized decoupling of transients. A supply voltage above the UVLO threshold for V_{PWR} must be supplied for the device to power on.

10.2 V_{REF} Pin

The V_{REF} pin provides a voltage reference for the data switch OVP level as well as a bypass for ESD clamping. A 1- μ F capacitor must be placed as close to the pin as possible and the supply must be set to be above the UVLO threshold for V_{REF} .

11 Layout

11.1 Layout Guidelines

Proper routing and placement maintains signal integrity for high-speed signals. The following guidelines apply to the TPD2S703-Q1:

- Place the bypass capacitors as close as possible to the VPWR and VREF pins. Capacitors must be attached to a solid ground. This minimizes voltage disturbances during transient events such as short-to-battery, ESD, or overcurrent conditions.
- High speed traces (data switch path) must be routed as straight as possible and any sharp bends must be minimized.

Standard ESD recommendations apply to the VD+, VD- pins as well:

- The optimum placement is as close to the connector as possible.
 - EMI during an ESD event can couple from the trace being struck to other nearby unprotected traces, resulting in early system failures.
 - The PCB designer must minimize the possibility of EMI coupling by keeping any unprotected traces away from the protected traces which are between the TVS and the connector.
- Route the protected traces as straight as possible.
- Eliminate any sharp corners on the protected traces between the TVS and the connector by using rounded corners with the largest radii possible.
 - Electric fields tend to build up on corners, increasing EMI coupling.

11.2 Layout Example

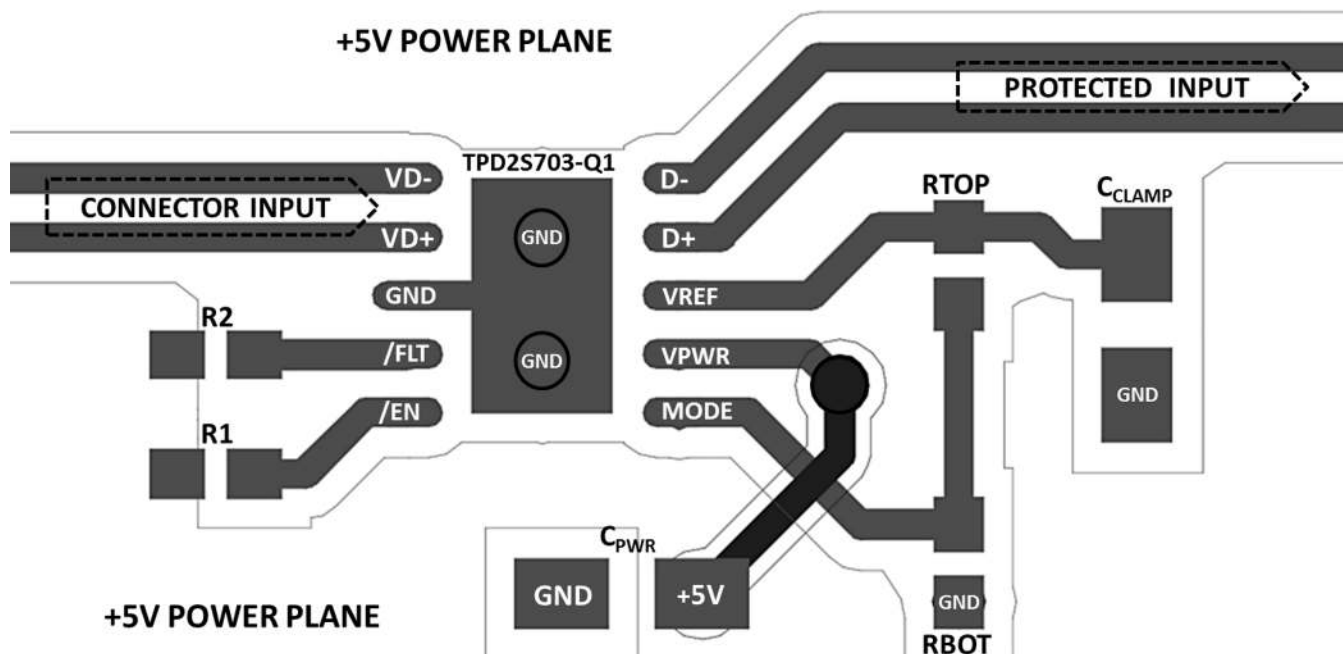

Figure 26. TPD2S703-Q1 Layout

12 Device and Documentation Support

12.1 Documentation Support

12.1.1 Related Documentation

For related documentation see the following:

[TPD2S703-Q1 Evaluation Module User's Guide](#)

12.2 Receiving Notification of Documentation Updates

To receive notification of documentation updates, navigate to the device product folder on [ti.com](#). In the upper right corner, click on *Alert me* to register and receive a weekly digest of any product information that has changed. For change details, review the revision history included in any revised document.

12.3 Support Resources

[TI E2E™ support forums](#) are an engineer's go-to source for fast, verified answers and design help — straight from the experts. Search existing answers or ask your own question to get the quick design help you need.

Linked content is provided "AS IS" by the respective contributors. They do not constitute TI specifications and do not necessarily reflect TI's views; see TI's [Terms of Use](#).

12.4 Trademarks

E2E is a trademark of Texas Instruments.

All other trademarks are the property of their respective owners.

12.5 Electrostatic Discharge Caution



This integrated circuit can be damaged by ESD. Texas Instruments recommends that all integrated circuits be handled with appropriate precautions. Failure to observe proper handling and installation procedures can cause damage.

ESD damage can range from subtle performance degradation to complete device failure. Precision integrated circuits may be more susceptible to damage because very small parametric changes could cause the device not to meet its published specifications.

12.6 Glossary

[SLYZ022](#) — *TI Glossary*.

This glossary lists and explains terms, acronyms, and definitions.

13 Mechanical, Packaging, and Orderable Information

The following pages include mechanical, packaging, and orderable information. This information is the most current data available for the designated devices. This data is subject to change without notice and revision of this document. For browser-based versions of this data sheet, refer to the left-hand navigation.

PACKAGING INFORMATION

Orderable Device	Status (1)	Package Type	Package Drawing	Pins	Package Qty	Eco Plan (2)	Lead finish/ Ball material (6)	MSL Peak Temp (3)	Op Temp (°C)	Device Marking (4/5)	Samples
TPD2S703QDGSRQ1	ACTIVE	VSSOP	DGS	10	2500	RoHS & Green	NIPDAUAG	Level-2-260C-1 YEAR	-40 to 125	13Z	Samples
TPD2S703QDSKRQ1	ACTIVE	SON	DSK	10	3000	RoHS & Green	NIPDAU	Level-2-260C-1 YEAR	-40 to 125	14XI	Samples

(1) The marketing status values are defined as follows:

ACTIVE: Product device recommended for new designs.

LIFEBUY: TI has announced that the device will be discontinued, and a lifetime-buy period is in effect.

NRND: Not recommended for new designs. Device is in production to support existing customers, but TI does not recommend using this part in a new design.

PREVIEW: Device has been announced but is not in production. Samples may or may not be available.

OBSOLETE: TI has discontinued the production of the device.

(2) **RoHS:** TI defines "RoHS" to mean semiconductor products that are compliant with the current EU RoHS requirements for all 10 RoHS substances, including the requirement that RoHS substance do not exceed 0.1% by weight in homogeneous materials. Where designed to be soldered at high temperatures, "RoHS" products are suitable for use in specified lead-free processes. TI may reference these types of products as "Pb-Free".

RoHS Exempt: TI defines "RoHS Exempt" to mean products that contain lead but are compliant with EU RoHS pursuant to a specific EU RoHS exemption.

Green: TI defines "Green" to mean the content of Chlorine (Cl) and Bromine (Br) based flame retardants meet JS709B low halogen requirements of <=1000ppm threshold. Antimony trioxide based flame retardants must also meet the <=1000ppm threshold requirement.

(3) MSL, Peak Temp. - The Moisture Sensitivity Level rating according to the JEDEC industry standard classifications, and peak solder temperature.

(4) There may be additional marking, which relates to the logo, the lot trace code information, or the environmental category on the device.

(5) Multiple Device Markings will be inside parentheses. Only one Device Marking contained in parentheses and separated by a "~" will appear on a device. If a line is indented then it is a continuation of the previous line and the two combined represent the entire Device Marking for that device.

(6) Lead finish/Ball material - Orderable Devices may have multiple material finish options. Finish options are separated by a vertical ruled line. Lead finish/Ball material values may wrap to two lines if the finish value exceeds the maximum column width.

Important Information and Disclaimer:The information provided on this page represents TI's knowledge and belief as of the date that it is provided. TI bases its knowledge and belief on information provided by third parties, and makes no representation or warranty as to the accuracy of such information. Efforts are underway to better integrate information from third parties. TI has taken and continues to take reasonable steps to provide representative and accurate information but may not have conducted destructive testing or chemical analysis on incoming materials and chemicals. TI and TI suppliers consider certain information to be proprietary, and thus CAS numbers and other limited information may not be available for release.

In no event shall TI's liability arising out of such information exceed the total purchase price of the TI part(s) at issue in this document sold by TI to Customer on an annual basis.

TAPE AND REEL INFORMATION

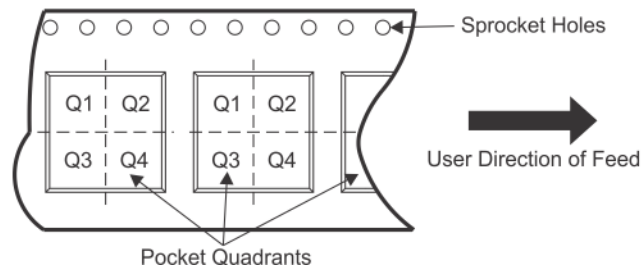
QUADRANT ASSIGNMENTS FOR PIN 1 ORIENTATION IN TAPE

*All dimensions are nominal

Device	Package Type	Package Drawing	Pins	SPQ	Reel Diameter (mm)	Reel Width W1 (mm)	A0 (mm)	B0 (mm)	K0 (mm)	P1 (mm)	W (mm)	Pin1 Quadrant
TPD2S703QDGSRQ1	VSSOP	DGS	10	2500	330.0	12.4	5.3	3.4	1.4	8.0	12.0	Q1
TPD2S703QDSKRQ1	SON	DSK	10	3000	180.0	8.4	2.8	2.8	1.0	4.0	8.0	Q2

TAPE AND REEL BOX DIMENSIONS



*All dimensions are nominal

Device	Package Type	Package Drawing	Pins	SPQ	Length (mm)	Width (mm)	Height (mm)
TPD2S703QDGSRQ1	VSSOP	DGS	10	2500	366.0	364.0	50.0
TPD2S703QDSKRQ1	SON	DSK	10	3000	210.0	185.0	35.0

DGS0010A



PACKAGE OUTLINE

VSSOP - 1.1 mm max height

SMALL OUTLINE PACKAGE

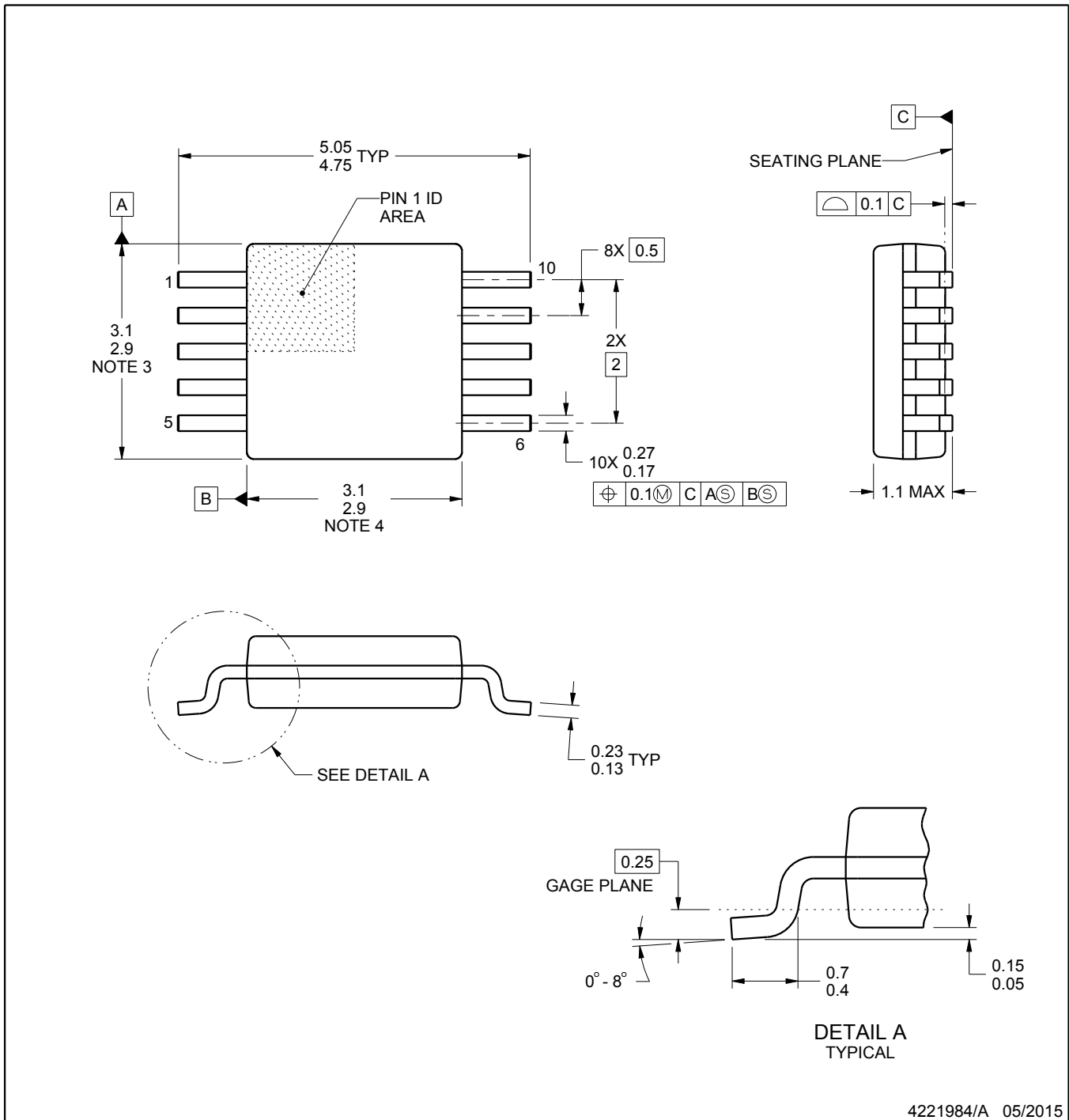

4221984/A 05/2015

NOTES:

1. All linear dimensions are in millimeters. Any dimensions in parenthesis are for reference only. Dimensioning and tolerancing per ASME Y14.5M.
2. This drawing is subject to change without notice.
3. This dimension does not include mold flash, protrusions, or gate burrs. Mold flash, protrusions, or gate burrs shall not exceed 0.15 mm per side.
4. This dimension does not include interlead flash. Interlead flash shall not exceed 0.25 mm per side.
5. Reference JEDEC registration MO-187, variation BA.

EXAMPLE BOARD LAYOUT

DGS0010A

VSSOP - 1.1 mm max height

SMALL OUTLINE PACKAGE

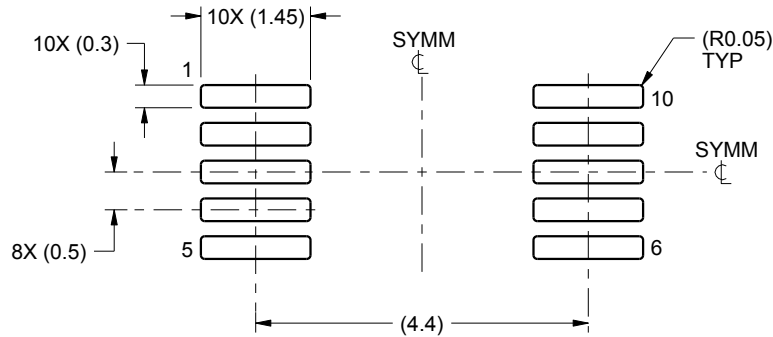

LAND PATTERN EXAMPLE
SCALE:10X

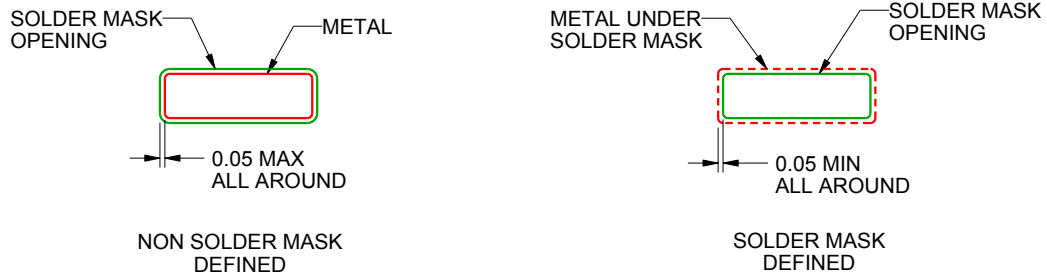

SOLDER MASK DETAILS
NOT TO SCALE

4221984/A 05/2015

NOTES: (continued)

6. Publication IPC-7351 may have alternate designs.
7. Solder mask tolerances between and around signal pads can vary based on board fabrication site.

EXAMPLE STENCIL DESIGN

DGS0010A

VSSOP - 1.1 mm max height

SMALL OUTLINE PACKAGE

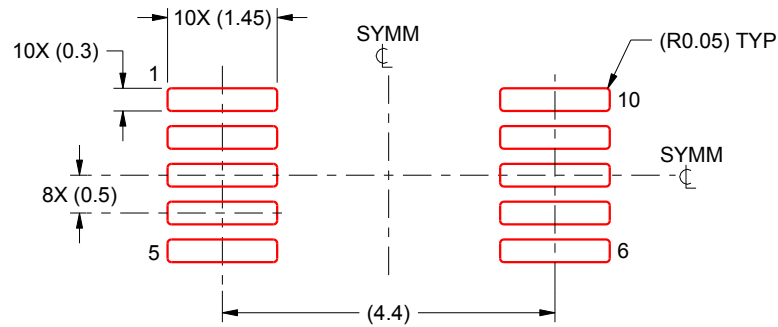

SOLDER PASTE EXAMPLE
BASED ON 0.125 mm THICK STENCIL
SCALE:10X

4221984/A 05/2015

NOTES: (continued)

8. Laser cutting apertures with trapezoidal walls and rounded corners may offer better paste release. IPC-7525 may have alternate design recommendations.
9. Board assembly site may have different recommendations for stencil design.

GENERIC PACKAGE VIEW

DSK 10

WSON - 0.8 mm max height

2.5 x 2.5 mm, 0.5 mm pitch

PLASTIC SMALL OUTLINE - NO LEAD

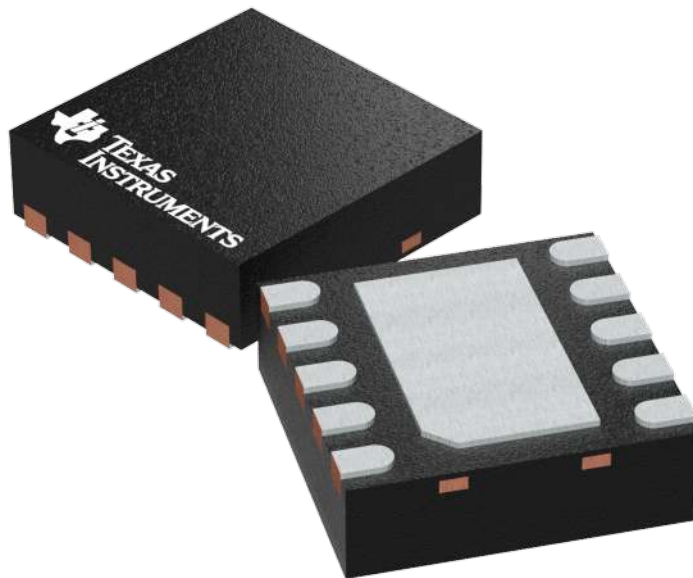

Images above are just a representation of the package family, actual package may vary.
Refer to the product data sheet for package details.

4225304/A

EXAMPLE STENCIL DESIGN

DSK0010A

WSON - 0.8 mm max height

PLASTIC SMALL OUTLINE - NO LEAD

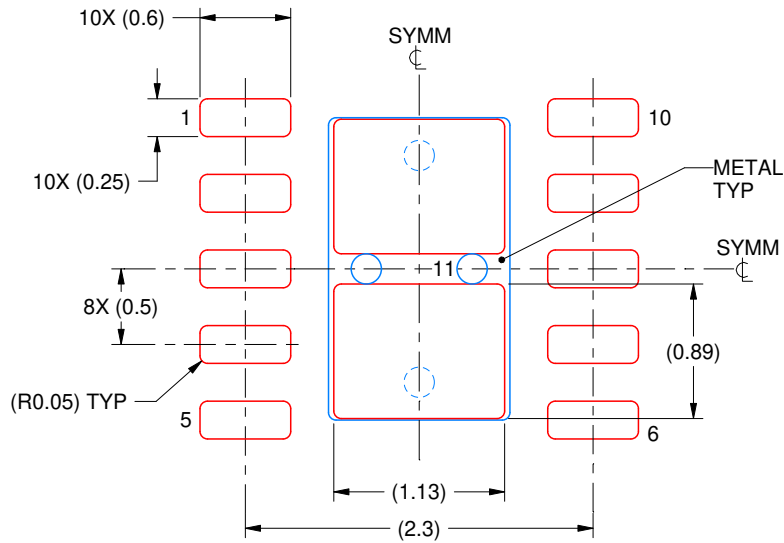

SOLDER PASTE EXAMPLE
BASED ON 0.125 mm THICK STENCIL

EXPOSED PAD 11
84% PRINTED SOLDER COVERAGE BY AREA
SCALE:20X

4218903/B 10/2020

NOTES: (continued)

6. Laser cutting apertures with trapezoidal walls and rounded corners may offer better paste release. IPC-7525 may have alternate design recommendations.

IMPORTANT NOTICE AND DISCLAIMER

TI PROVIDES TECHNICAL AND RELIABILITY DATA (INCLUDING DATA SHEETS), DESIGN RESOURCES (INCLUDING REFERENCE DESIGNS), APPLICATION OR OTHER DESIGN ADVICE, WEB TOOLS, SAFETY INFORMATION, AND OTHER RESOURCES "AS IS" AND WITH ALL FAULTS, AND DISCLAIMS ALL WARRANTIES, EXPRESS AND IMPLIED, INCLUDING WITHOUT LIMITATION ANY IMPLIED WARRANTIES OF MERCHANTABILITY, FITNESS FOR A PARTICULAR PURPOSE OR NON-INFRINGEMENT OF THIRD PARTY INTELLECTUAL PROPERTY RIGHTS.

These resources are intended for skilled developers designing with TI products. You are solely responsible for (1) selecting the appropriate TI products for your application, (2) designing, validating and testing your application, and (3) ensuring your application meets applicable standards, and any other safety, security, regulatory or other requirements.

These resources are subject to change without notice. TI grants you permission to use these resources only for development of an application that uses the TI products described in the resource. Other reproduction and display of these resources is prohibited. No license is granted to any other TI intellectual property right or to any third party intellectual property right. TI disclaims responsibility for, and you will fully indemnify TI and its representatives against, any claims, damages, costs, losses, and liabilities arising out of your use of these resources.

TI's products are provided subject to [TI's Terms of Sale](#) or other applicable terms available either on [ti.com](#) or provided in conjunction with such TI products. TI's provision of these resources does not expand or otherwise alter TI's applicable warranties or warranty disclaimers for TI products.

TI objects to and rejects any additional or different terms you may have proposed.

Mailing Address: Texas Instruments, Post Office Box 655303, Dallas, Texas 75265
Copyright © 2023, Texas Instruments Incorporated