

HFBR-0541Z Evaluation Kit

DC to 16MBd Sercos 650nm Fiber Optics Eval Kit



User Guide

Introduction

HFBR-0541Z evaluation kit is used to evaluate Avago fiber optic device HFBR-1506AMZ and HFBR-2506AMZ. The evaluation kit is equipped with necessary documents and accessories to ease product evaluation and verification.

Evaluation Kit

HFBR-0541Z contains:

1. Evaluation board
2. HFBR-1506AMZ and HFBR-2506AMZ unit
3. HCS Cable with SMA connector
4. HFBR-1506AMZ /2506AMZ datasheet
5. User guide document

Evaluation Board

The basic evaluation board that you receive from Avago incorporates transmitter driver IC SN75451BD, some passive components, and SMA connectors for the TX input (TXD) and RX output (RXD) port connection. This basic evaluation board allows you to connect waveform/pattern generator to the TXD with TTL input signal. Receiver's output signal can be monitored from the RXD or RXout with oscilloscope by using high impedance setting.

Initial Setup

1. Connect 5V supply voltage to TXVCC and RXVCC
2. Connect 0V to TXGND and RXGND
3. Connect TXD to pattern generator output
4. Connect RXout to Oscilloscope with high impedance probe

Bit Error Rate Test Setup

Though the transmitter driver IC's input and receiver's output is based on TTL logic (high impedance), the board can be modified to connect 50ohm load instrument by doing the following steps:

1. Put R2 (50 ohm resistor).
2. Remove R3 (0 ohm resistor).
3. Put R4 (0 ohm resistor) and R7 (50 ohm resistor).
4. Put U3 (SN74LVC2G125).
5. Connect BVCC (5V) and BGND (0V).

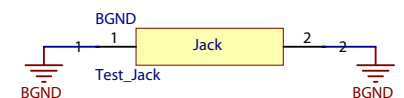
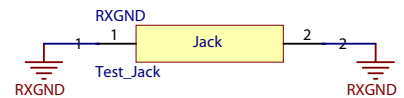
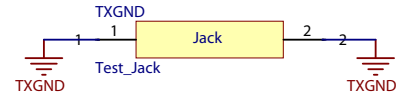
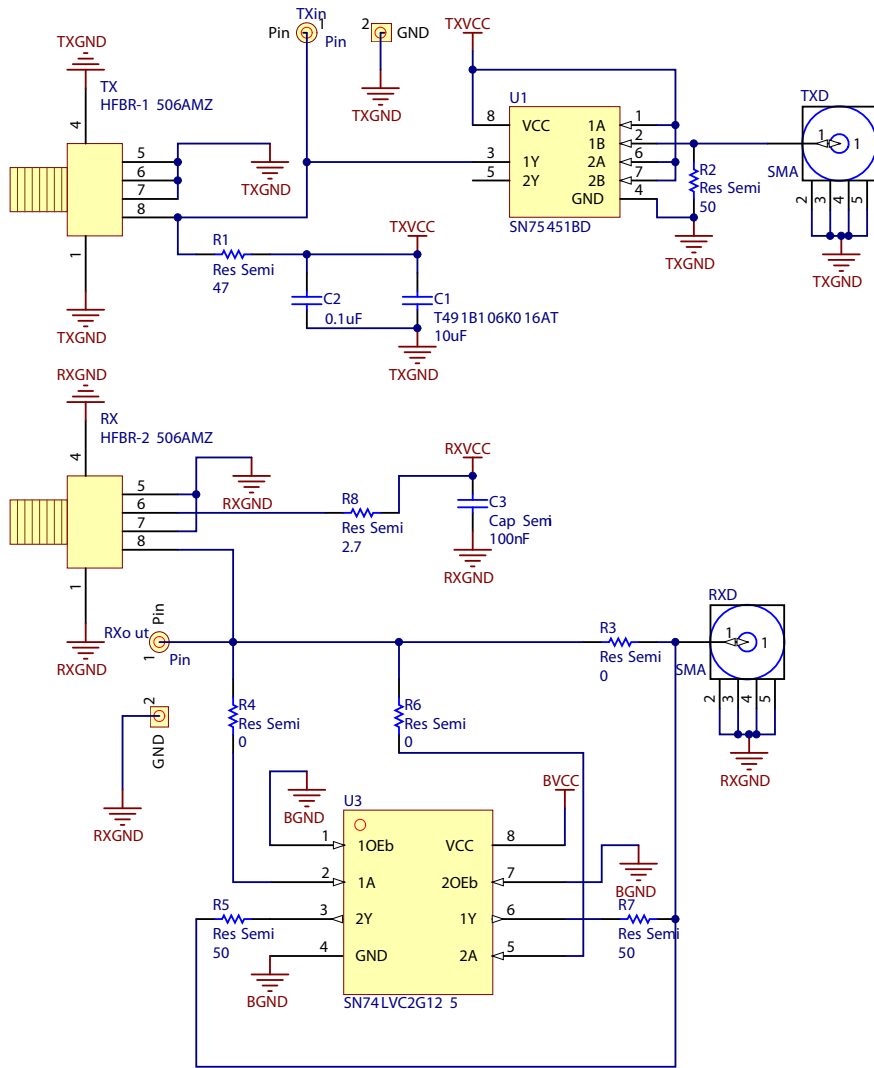

For product information and a complete list of distributors, please go to our web site: www.avagotech.com

Avago, Avago Technologies, and the A logo are trademarks of Avago Technologies in the United States and other countries. Data subject to change. Copyright © 2005-2010 Avago Technologies. All rights reserved. AV02-2721EN - November 4, 2010

