

- NOTE
- MATED WITH : 104121-0600
 - MATERIAL
 - HEADER : THERMOPLASTIC, HALOGEN FREE UL94V-0, COLOR OF NATURAL
 - PICK-UP COVER : THERMOPLASTIC, UL94V-0, COLOR OF NATURAL
 - CONTACT TERMINAL : COPPER ALLOY (t=0.2)
 - FITTING NAIL : COPPER ALLOY (t=0.15)
 - FINISHES
 - CONTACT TERMINAL : PURE-TIN PLATING ON OVERALL. THICKNESS 3.0µm~5.0µm UNDER PLATING Ni OVERALL. THICKNESS 1.25µm~3.75µm
 - FITTING NAIL : PURE-TIN PLATING ON OVERALL. THICKNESS 3.0µm~5.0µm UNDER PLATING Ni OVERALL. THICKNESS 1.25µm~3.75µm
 - COPLANALITY OF SOLDER TAILS (PEAK TEMP. : 260°C),
 - BEFORE REFLOW : 0.08 MAX.
 - AFTER REFLOW : 0.1 MAX.
 - PRODUCT SPECIFICATION : PS-104122-001
 - PACKING INFORMATION : PK-104122-001

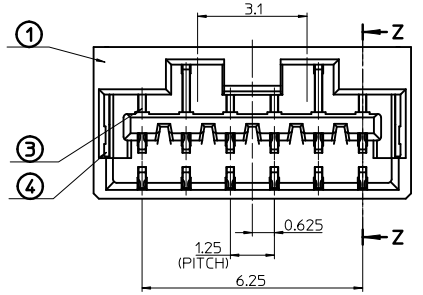

WHEN PICK UP COVER IS REMOVED

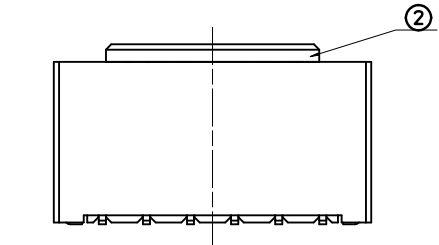
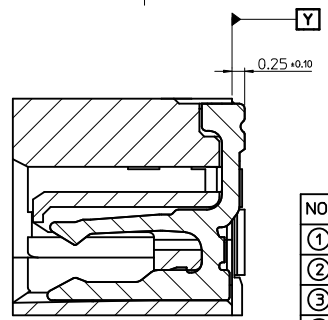

SECTION Z-Z (SCALE 10:1)

<PART LIST>

NO.	PART NAME
①	HEADER
②	PICK-UP COVER
③	CONTACT TERMINAL
④	FITTING NAIL

REVISED
 EC NO: KOR2012-0069
 DRWN:SKCHO 2012/01/05
 CHKD:SHCHU 2012/01/05
 APPR:YSKIM02 2012/03/26

QUALITY SYMBOLS
 ▽=0
 ◻=0

GENERAL TOLERANCES (UNLESS SPECIFIED)

	mm	INCH
4 PLACES	± ---	± ---
3 PLACES	± ---	± ---
2 PLACES	± 0.15	± ---
1 PLACE	± 0.25	± ---
ANGULAR ± 1 °		

DRAFT WHERE APPLICABLE MUST REMAIN WITHIN DIMENSIONS

DIMENSION STYLE MM ONLY

DRAWN BY	DATE
HTSONG	2010/10/28
CHECKED BY	DATE
SHCHU	2010/10/28
APPROVED BY	DATE
YSOOKIM	2010/10/28

MATERIAL NO. SEE TABLE

ORDER NO.	104122-0617
COLOR	NATURAL
SCALE	7/1
DESIGN UNITS	METRIC
THIRD ANGLE PROJECTION	
1.25 W/B CONN. ST. 6P HEADER ASS'Y	
MOLEX INCORPORATED	
DOCUMENT NO.	SD-104122-001
SHEET NO.	1 OF 1

THIS DRAWING CONTAINS INFORMATION THAT IS PROPRIETARY TO MOLEX INCORPORATED AND SHOULD NOT BE USED WITHOUT WRITTEN PERMISSION

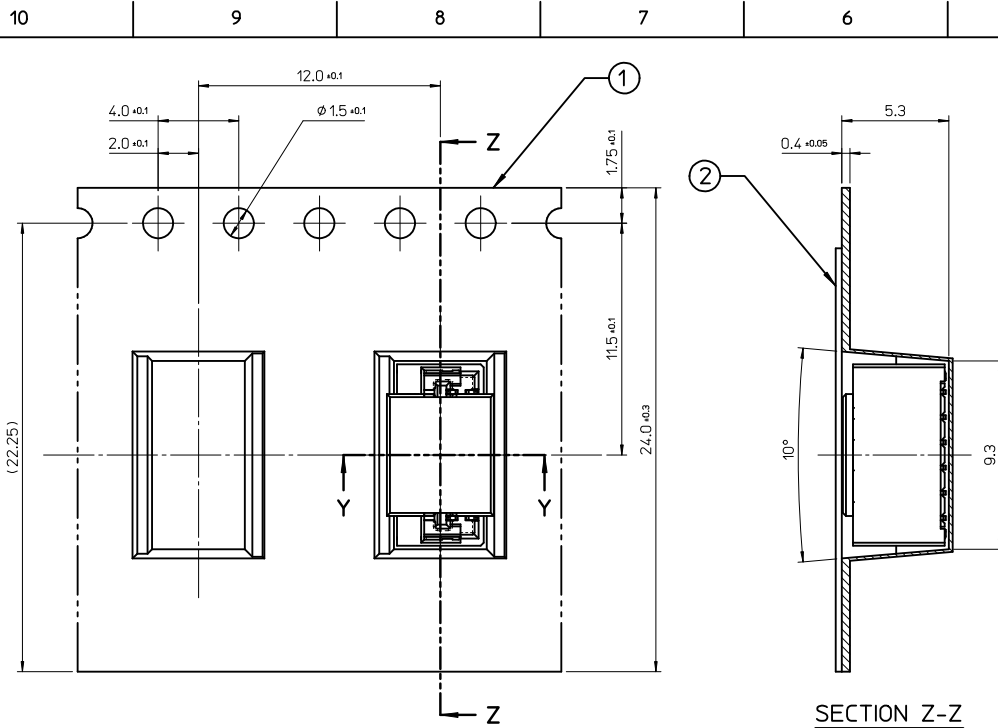

NOTE
1. QUANTITY OF CONNECTORS : 1,300 PCS/REEL

2. LEAD LENGTH

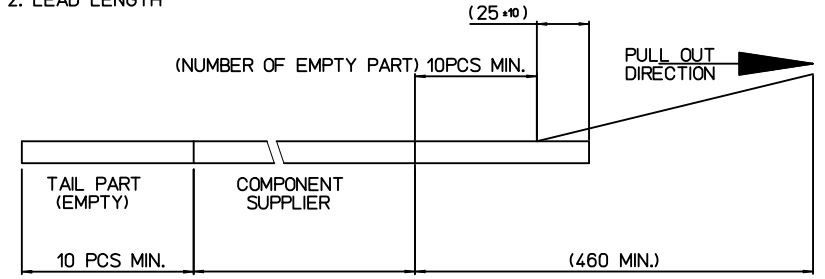

3. PEELING OFF FORCE OF COVER TAPE : 0.1N~0.59N(10.2GF~60GF)
(PEELING DIRECTION AS SHOW IN FOLLOW FIG.)
PEELING OFF SPEED : 300mm/Min.(Ref.)

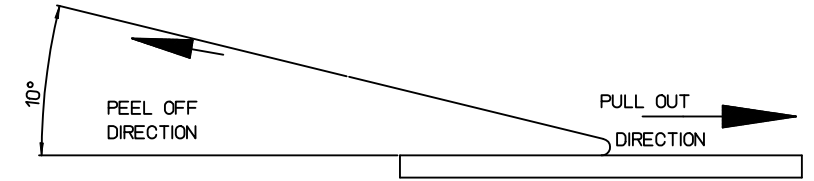

4. FLASH IN ANY PORTION SHOULD BE LESS THAN 0.20mm MAX.
5. UNLESS OTHERWISE SPECIFIED INNER R0.2 MAX
6. DRAFT ANGLE 3°MAX

<TABLE>

104122-0617	104122-0617	24.0mm	104122-0001
MATERIAL NO.	CONNECTOR	TAPE WIDTH	EMBOSS TAPE

③	PLASTIC BOBBIN	HI P.S	WHITE
②	COVER TAPE	PET ANTISTATIC	21.0mm
①	CARRIER (EMBOSS) TAPE	PET ANTISTATIC	
NO.	DESCRIPTION	MATERIAL	REMARK

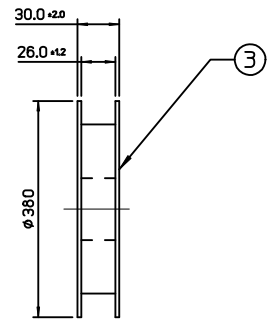
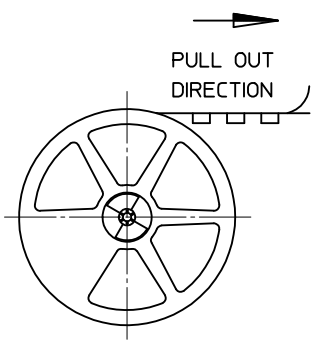
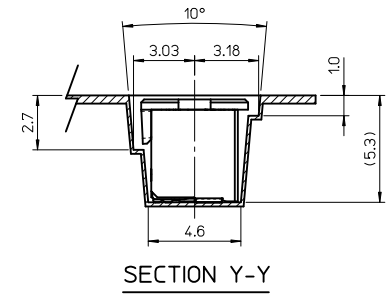
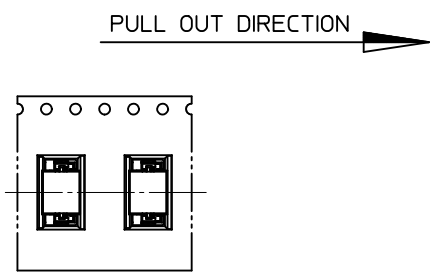

RELEASED
EC NO: KOR2011-0122 2011/04/26
DRWN:SKCHO
CHKD:
APPR:YUNSIKKIM 2011/04/29

QUALITY SYMBOLS
▽=0
∇=0

GENERAL TOLERANCES (UNLESS SPECIFIED)
mm INCH
4 PLACES ± --- ± ---
3 PLACES ± --- ± ---
2 PLACES ± 0.15 ± ---
1 PLACE ± 0.25 ± ---
ANGULAR ± 3 °
DRAFT WHERE APPLICABLE MUST REMAIN WITHIN DIMENSIONS

DIMENSION STYLE MM ONLY
DRAWN BY HTSONG DATE 2010/10/28
CHECKED BY SHCHU DATE 2010/10/28
APPROVED BY YUNSIKKIM DATE 2011/04/29
MATERIAL NO. SEE TABLE

SCALE 4:1
DESIGN UNITS METRIC
THIRD ANGLE PROJECTION
TITLE 1.25 W/B CONN. ST. 6P EMBOSS PACKAGE
MOLEX INCORPORATED
DOCUMENT NO. SD-104122-002
SHEET NO. 1 OF 1
THIS DRAWING CONTAINS INFORMATION THAT IS PROPRIETARY TO MOLEX INCORPORATED AND SHOULD NOT BE USED WITHOUT WRITTEN PERMISSION