

**Product Specification**

---

# NHD-7.0-1024600AF-LSXP

## IPS TFT Liquid Crystal Display Module

<b>NHD -</b>	Newhaven Display
<b>7.0 -</b>	7.0" Diagonal
<b>1024600 -</b>	1024xRGBx600 Pixels
<b>AF -</b>	Model
<b>L -</b>	LVDS Interface
<b>S -</b>	High Brightness, White LED Backlight
<b>X -</b>	TFT
<b>P -</b>	IPS, Wide Temperature

## Table of Contents

Document Revision History .....	2
Mechanical Drawing .....	3
Pin Description .....	4
Electrical Characteristics .....	5
Optical Characteristics .....	5
Driver Information .....	5
Timing Characteristics .....	6
Quality Information .....	8

---

## Additional Resources

- **Support Forum:** <http://www.nhdforum.newhavendisplay.com>
- **Github:** <https://github.com/newhavendisplay>
- **Example Code:** [https://www.newhavendisplay.com/example\\_code.html](https://www.newhavendisplay.com/example_code.html)
- **Knowledge Center:** [https://www.newhavendisplay.com/knowledge\\_center.html](https://www.newhavendisplay.com/knowledge_center.html)
- **Quality Center:** [https://www.newhavendisplay.com/quality\\_center.html](https://www.newhavendisplay.com/quality_center.html)
- **Precautions for using LCDs/LCMs:** <https://www.newhavendisplay.com/specs/precautions.pdf>
- **Warranty / Terms & Conditions:** <https://www.newhavendisplay.com/terms.html>



## Document Revision History

Revision	Date	Description	Changed By
-	4/22/19	Initial Release	PK
1	6/18/19	Backlight Characteristics Updated	SB
2	7/21/20	Updated 2D Mechanical Drawing; Kapton Tape to Golden Fingers	AS
3	7/27/20	Included Horizontal & Vertical Timing Charts	AS
4	4/27/21	Updated the Electrical Characteristics	JT
5	8/12/21	Updated Electrical, Optical Characteristics, and Mechanical Drawing. Part Revision updated to Rev2A.	JT
6	01/26/22	Updated supply current for LCD, Chromaticity values, and Note section in Mechanical Drawing.	JT
7	03/10/22	Updated Mechanical Drawing	CJ

# Mechanical Drawing

SYMBOL	REVISION	DATE

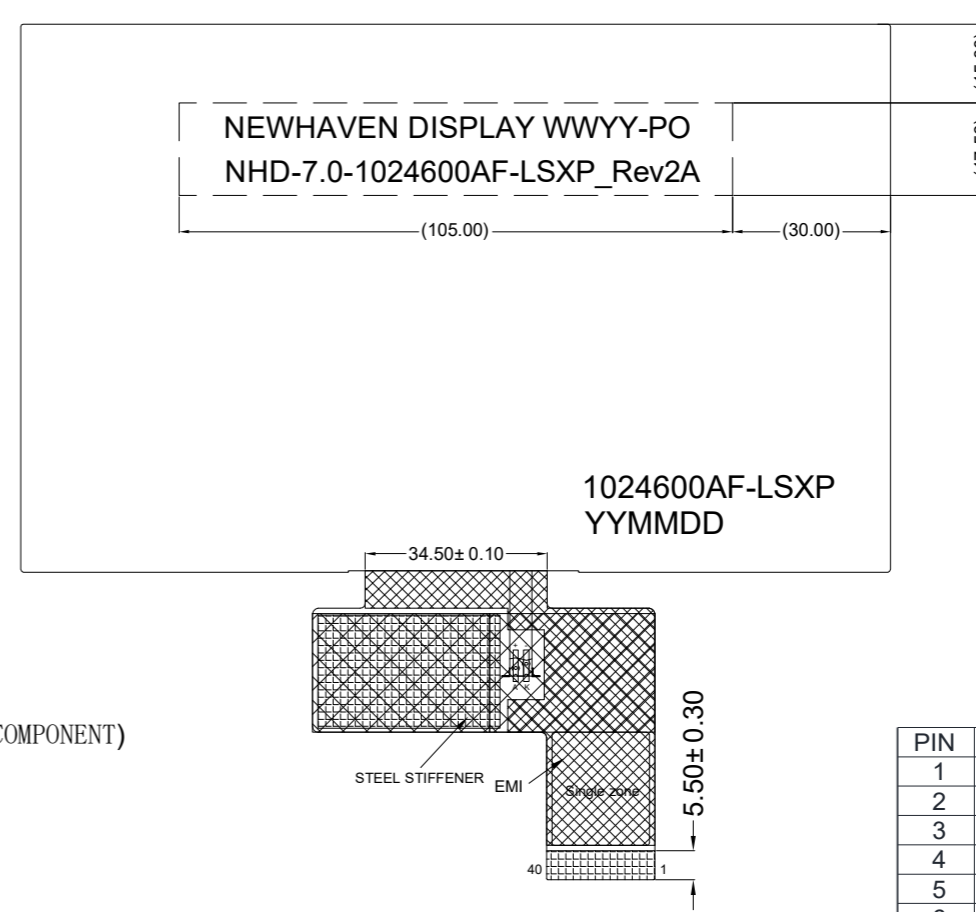
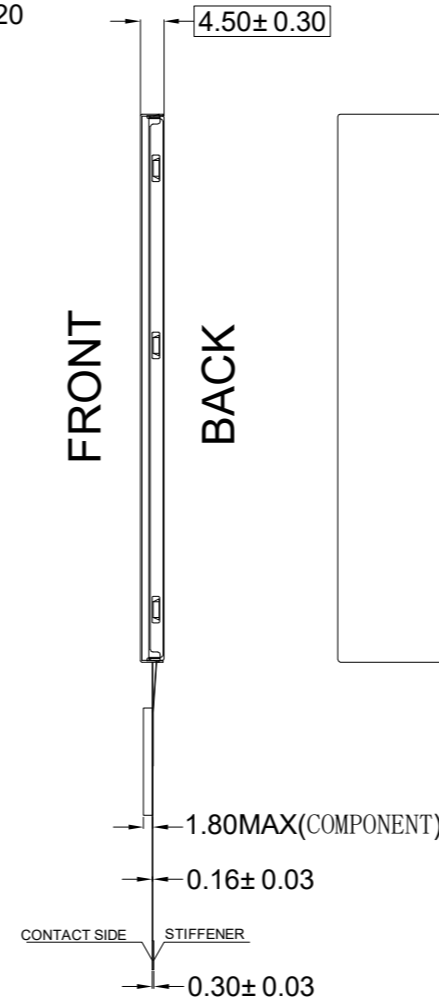
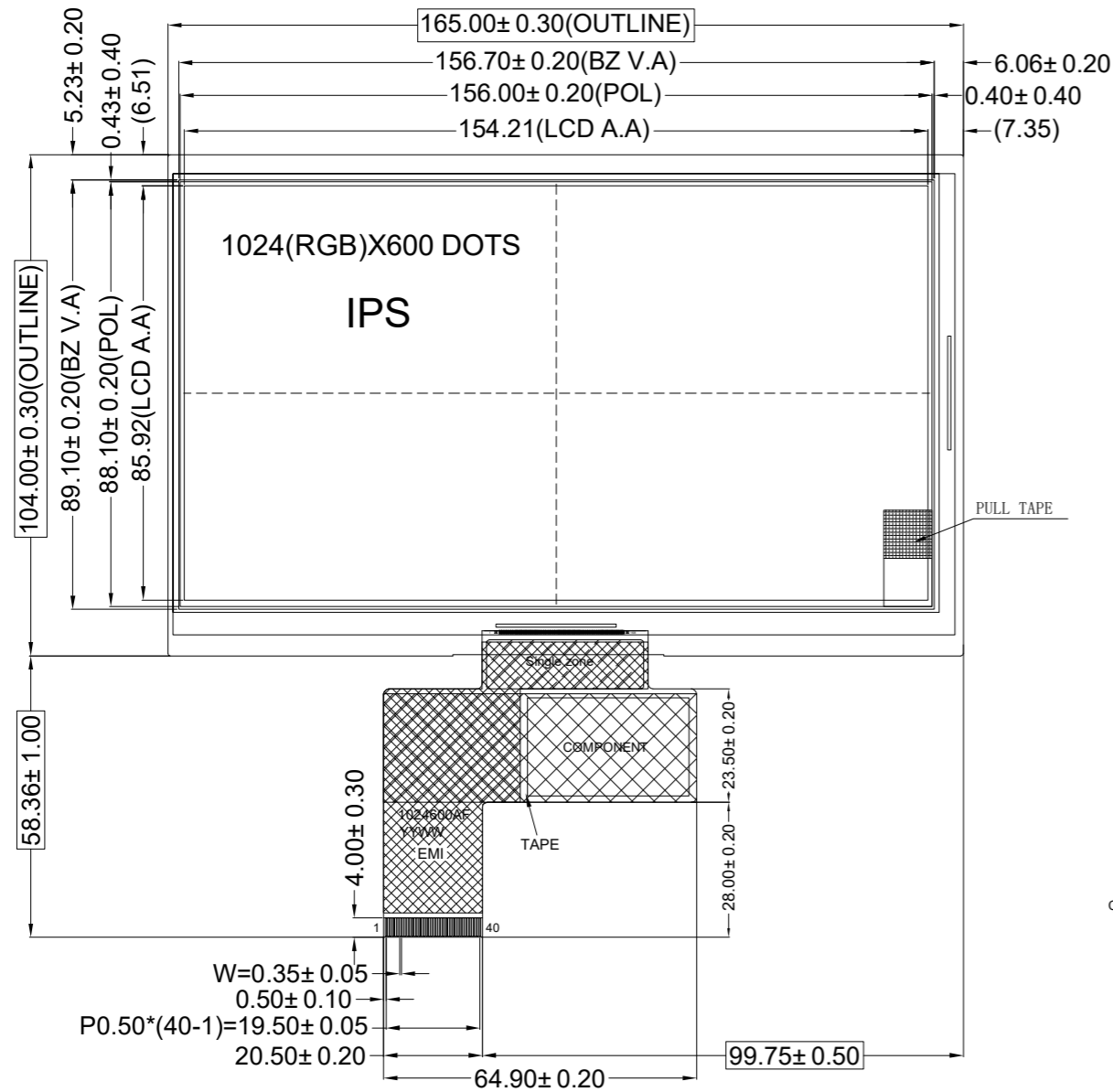

PIN	SYMBOL	PIN	SYMBOL
1	NC	21	Rin3+
2	VDD	22	GND
3	VDD	23	NC
4	NC	24	NC
5	/RES	25	GND
6	/STBYB	26	NC
7	GND	27	BIST
8	Rin0-	28	INSEL
9	Rin0+	29	NC
10	GND	30	GND
11	Rin1-	31	NC
12	Rin1+	32	NC
13	GND	33	SHLR
14	Rin2-	34	UPDN
15	Rin2+	35	NC
16	GND	36	LED-K
17	CLKIN-	37	LED-K
18	CLKIN+	38	NC
19	GND	39	LED-A
20	Rin3-	40	LED-A

## Product Description: 7" IPS TFT

1. TFT Driver IC: HX8282-A11+HX8696-A01
2. TFT Interface: LVDS
3. TFT Power Requirement: 3.3V, Backlight: 150mA (19.2 V Reference)
4. Optical Features: Transmissive, Normally Black, 1100cd/m<sup>2</sup> (Typ)
5. TFT Mating Connector: 40pin, 0.5mm pitch; EX.Molex 54104-4031

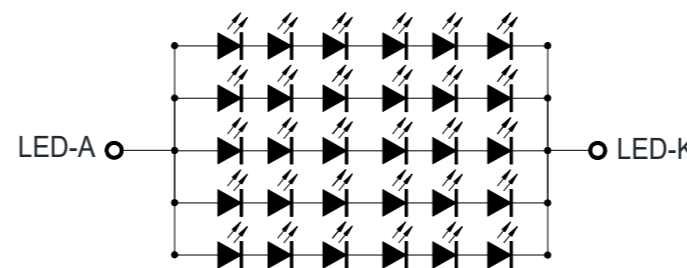

<b>Standard Tolerance:</b> (Unless otherwise specified)  Linear: ±0.3mm		
	Drawing/Part Number: <b>NHD-7.0-1024600AF-LSXP</b>	Revision: 2A
<b>Unless otherwise specified:</b> • Dimensions are in Millimeters • Third Angle Projection	Drawn By: C. Johnson Drawn Date: 03/10/2022	Approved By: C. Johnson Approved Date: 03/10/2022
	<b>Do Not Scale Drawing</b>	
This drawing is solely the property of Newhaven Display International, Inc. The information it contains is not to be disclosed, reproduced or copied in whole or part without written approval from Newhaven Display.		Sheet 1 of 1

## Pin Description

Pin No.	Symbol	Connection	Function Description
1	NC	-	No connection
2-3	V <sub>DD</sub>	Power Supply	Supply voltage for LCD (+3.3V)
4	NC	-	No connection
5	/RES	MPU	Active LOW Reset signal (normally pull high)
6	/STBYB	MPU	Active LOW Standby signal (normally pull high)
7	GND	Power Supply	Power Ground
8	Rin0-	MPU	-LVDS differential data input CH0
9	Rin0+	MPU	+LVDS differential data input CH0
10	GND	Power Supply	Ground
11	Rin1-	MPU	-LVDS differential data input CH1
12	Rin1+	MPU	+LVDS differential data input CH1
13	GND	Power Supply	Ground
14	Rin2-	MPU	-LVDS differential data input CH2
15	Rin2+	MPU	+LVDS differential data input CH2
16	GND	Power Supply	Ground
17	CLKIN-	MPU	-LVDS differential Clock
18	CLKIN+	MPU	+LVDS differential Clock
19	GND	Power Supply	Ground
20	Rin3-	MPU	-LVDS differential data input CH3
21	Rin3+	MPU	+LVDS differential data input CH3
22	GND	Power Supply	Ground
23 - 24	NC	-	No connection
25	GND	Power Supply	Ground
26	NC	-	No Connection
27	BIST	MPU	Built in Self-Test BIST = H: Self-Test Enabled BIST = L: Normal Operation (Default)
28	INSEL	MPU	Data Input Format: INSEL = L 8-Bit LVDS Input (Default) INSEL = H 6-Bit LVDS Input
29	NC	-	No connection
30	GND	Power Supply	Power Ground
31-32	NC	-	No connection
33	SHLR	MPU	Gate Driver Left/Right Scan Setting: SHLR = H: Normal Scan (Default) SHLR = L: Reverse Scan
34	UPDN	MPU	Gate Driver Up/Down Scan Setting: UPDN = H: Reverse Scan UPDN = L: Normal Scan (Default)
35	NC	-	No Connection
36-37	LED-K	Power Supply	Backlight Cathode (Ground)
38	NC	-	No connection
39-40	LED-A	Power Supply	Backlight Anode (150mA @ 19.2V)

**Recommended LCD connector:** 40pin 0.5mm pitch FFC. Molex P/N: 54104-4031 (top contact)

## Electrical Characteristics

Item	Symbol	Condition	Min.	Typ.	Max.	Unit
Operating Temperature Range	T <sub>OP</sub>	Absolute Max	-20	-	+70	°C
Storage Temperature Range	T <sub>ST</sub>	Absolute Max	-30	-	+80	°C
Supply Voltage for LCD	V <sub>DD</sub>	-	3.0	3.3	3.6	V
Supply Current for LCD	I <sub>DD</sub>	V <sub>DD</sub> = 3.3V	58	87	131	mA
LVDS Differential input high Threshold voltage	R <sub>XVTH</sub>	R <sub>XVCM</sub> = 1.2V	-	-	+100	mV
LVDS Differential input low Threshold voltage	R <sub>XVTL</sub>		-100	-	-	mV
LVDS Differential input common mode voltage	R <sub>XVCM</sub>	-	VID /2	-	2.4-  VID /2	V
LVDS Differential voltage	VID	-	200	-	600	mV
Backlight Supply Current	I <sub>LED</sub>	-	125	150	180	mA
Backlight Supply Voltage	V <sub>LED</sub>	I <sub>LED</sub> = 150 mA	18	19.2	20.4	V
Backlight Lifetime*	-	T <sub>OP</sub> = 25° C	30,000	-	-	Hrs.

\*Backlight lifetime is rated as Hours until **half-brightness**, under normal operating conditions. The LED of the backlight is driven by current drain; drive voltage is for reference only. Drive voltage must be selected to ensure backlight current drain is below MAX level stated

## Optical Characteristics

Item		Symbol	Condition	Min.	Typ.	Max.	Unit
Optimal Viewing Angles	Top	φY+	Cr ≥ 10	-	85	-	°
	Bottom	φY-		-	85	-	°
	Left	θX-		-	85	-	°
	Right	θX+		-	85	-	°
Contrast Ratio		CR	-	600	800	-	-
Luminance		L <sub>V</sub>	I <sub>LED</sub> = 150mA	800	1100	1500	cd/m <sup>2</sup>
Response Time		T <sub>R</sub> + T <sub>F</sub>	T <sub>OP</sub> = 25°C	-	30	40	ms
Chromaticity	Red	X <sub>R</sub>	-	0.552	0.592	0.632	-
		Y <sub>R</sub>	-	0.305	0.345	0.385	-
	Green	X <sub>G</sub>	-	0.277	0.317	0.357	-
		Y <sub>G</sub>	-	0.515	0.555	0.595	-
	Blue	X <sub>B</sub>	-	0.101	0.141	0.181	-
		Y <sub>B</sub>	-	0.069	0.109	0.149	-
	White	X <sub>W</sub>	-	0.26	0.30	0.34	-
		Y <sub>W</sub>	-	0.27	0.31	0.35	-

## Driver Information

Built-in HX8282 Source Driver: [https://www.newhavendisplay.com/resources\\_dataFiles/datasheets/LCDs/HX8282-A11.pdf](https://www.newhavendisplay.com/resources_dataFiles/datasheets/LCDs/HX8282-A11.pdf)

Built-in HX8696 Gate Driver: [https://www.newhavendisplay.com/resources\\_dataFiles/datasheets/LCDs/HX8696-A.pdf](https://www.newhavendisplay.com/resources_dataFiles/datasheets/LCDs/HX8696-A.pdf)



## Timing Characteristics

Parameter	Symbol	Spec			Unit	Condition
		Min.	Typ.	Max.		
Clock frequency	$R_{XFCLK}$	20	-	71	MHz	-
Input data skew margin	$T_{RSKM}$	500	-	-	pS	$ VID  = 400mV$ $R_{XVCM} = 1.2V$ $R_{XFCLK} = 71MHz$
Clock high time	$T_{LVCH}$	-	$4/(7 * R_{XFCLK})$	-	nS	-
Clock low time	$T_{LVCL}$	-	$3/(7 * R_{XFCLK})$	-	nS	-
PLL wake-up time	$T_{emPLL}$	-	-	150	$\mu S$	-

Parameter	Symbol	Spec			Unit	Condition
		Min.	Typ.	Max.		
Modulation Frequency	$SSC_{MF}$	23	-	93	KHz	-
Modulation Rate	$SSC_{MR}$	-	-	$\pm 3$	%	LVDS Clock = 71 MHz

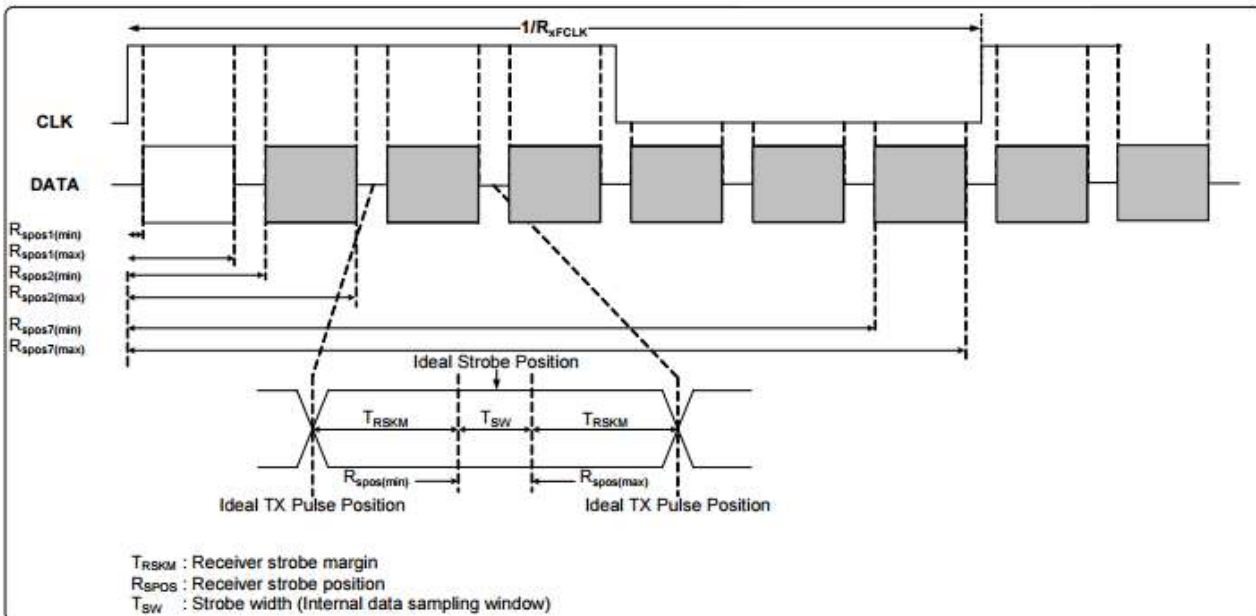
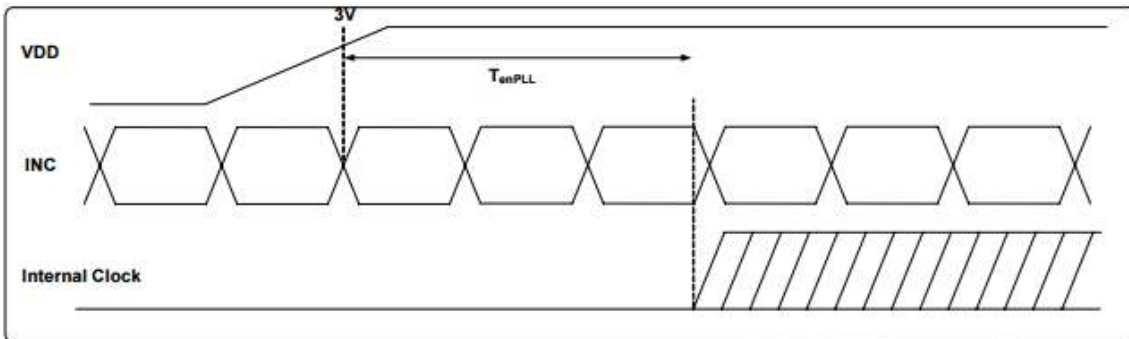
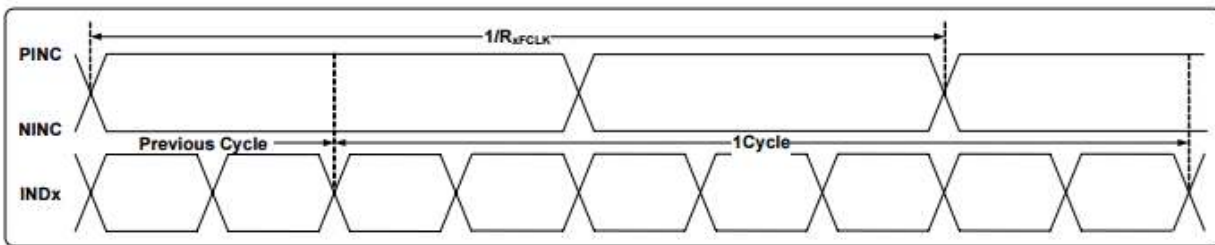

### 6-bit LVDS Data Input Format:

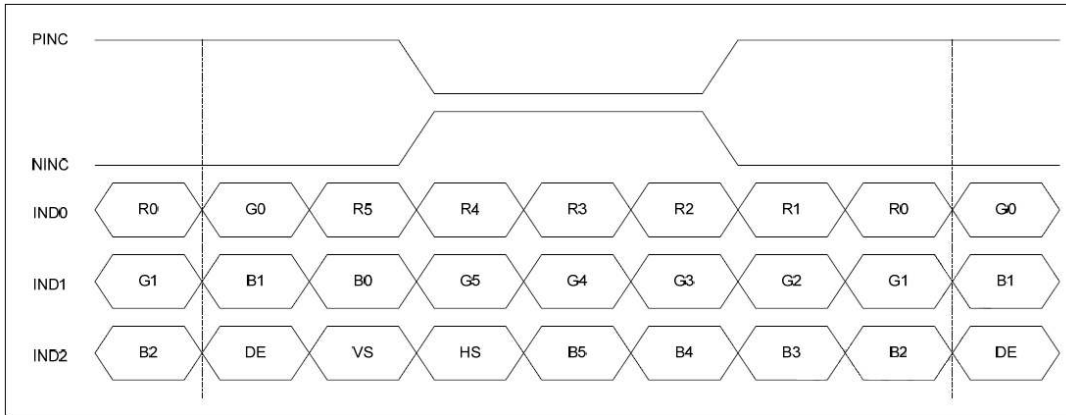

### 8-Bit LVDS Data Input Format:

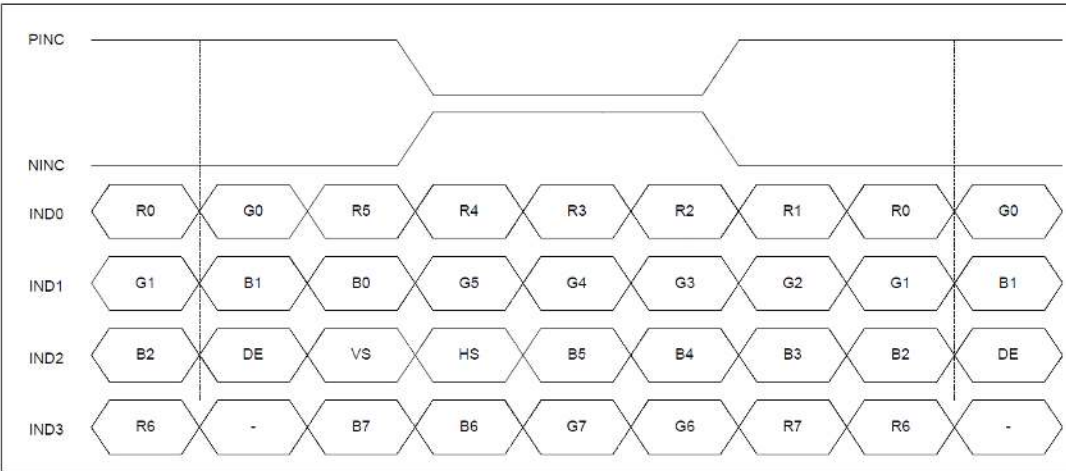

### Horizontal & Vertical Timing (1024x600)

Item	Symbol	Spec.			Unit	
		Min.	Typ.	Max.		
DCLK Frequency	F <sub>CLK</sub>	44.9	51.2	63	MHz	
HSYNC	Horizontal Display Area	T <sub>HD</sub>	1024			DCLK
	HSD Period	T <sub>H</sub>	1200	1344	1400	DCLK
	HSD Pulse Width	T <sub>HPW</sub>	1	-	140	DCLK
	HSD Back Porch	T <sub>HPB</sub>	160			DCLK
	HSD Front Porch	T <sub>HFP</sub>	16	160	216	DCLK
VSYNC	Vertical Display Area	T <sub>VD</sub>	600			T <sub>H</sub>
	VSD Period	T <sub>V</sub>	624	635	750	T <sub>H</sub>
	VSD Pulse Width	T <sub>VPW</sub>	1	-	20	T <sub>H</sub>
	VSD Back Porch	T <sub>VPB</sub>	23			T <sub>H</sub>
	VSD Front Porch	T <sub>VFP</sub>	1	12	127	T <sub>H</sub>



## Quality Information

Test Item	Content of Test	Test Condition	Note
High Temperature storage	Endurance test applying the high storage temperature for a long time.	+80°C, 240 hrs.	2
Low Temperature storage	Endurance test applying the low storage temperature for a long time.	-30°C, 240 hrs.	1,2
High Temperature Operation	Endurance test applying the electric stress (voltage & current) and the high thermal stress for a long time.	+70°C, 120 hrs.	2
Low Temperature Operation	Endurance test applying the electric stress (voltage & current) and the low thermal stress for a long time.	-20°C, 120 hrs.	1,2
High Temperature / Humidity Operation	Endurance test applying the electric stress (voltage & current) and the high thermal with high humidity stress for a long time.	+50°C, 90% RH, 120 hrs.	1,2
Thermal Shock resistance	Endurance test applying the electric stress (voltage & current) during a cycle of low and high thermal stress.	-30°C, 30min->25°C, 10min -> 80°C, 30min 10 cycles	
Vibration test	Endurance test applying vibration to simulate transportation and use.	Frequency: 250 r/min Amplitude: 1 inch Time: 45min	3
Static electricity test	Endurance test applying electric static discharge.	Air: V <sub>s</sub> =±8KV, Contact: V <sub>s</sub> =±4KV 10 Times	

**Note 1:** No condensation to be observed.

**Note 2:** Conducted after 4 hours of storage at 25°C, 0%RH.

**Note 3:** Test performed on product itself, not inside a container.