

KA9258D

4-Channel Motor Driver

Features

- 1-Phase, Full-Wave, Linear DC Motor Driver
- Output Gain Adjustable
- Built in OP-AMP
- Built in Mute Function
- Built In Level Shift Circuit
- Built in Thermal Shutdown Circuit (TSD)
- Operating Range 6 ~ 13.2V

Description

The KA9258D is a monolithic integrated circuit, suitable for 4-CH motor driver which drives tracking actuator, focus actuator, sled motor and loading motor of CD/CD-ROM/DVD system, and can also drive spindle motor of CD system.



Typical Applications

- Compact Disk Player (CDP)
- Video Compact Disk Player (VCD)
- Automotive Compact Disk Player
- Other Compact Disk Media

Ordering Information

Device	Package	Operating Temp.
KA9258BD	28-SSOPH-375	-40°C ~ +85°C
KA9258BDTF	28-SSOPH-375	-40°C ~ +85°C

Pin Assignments

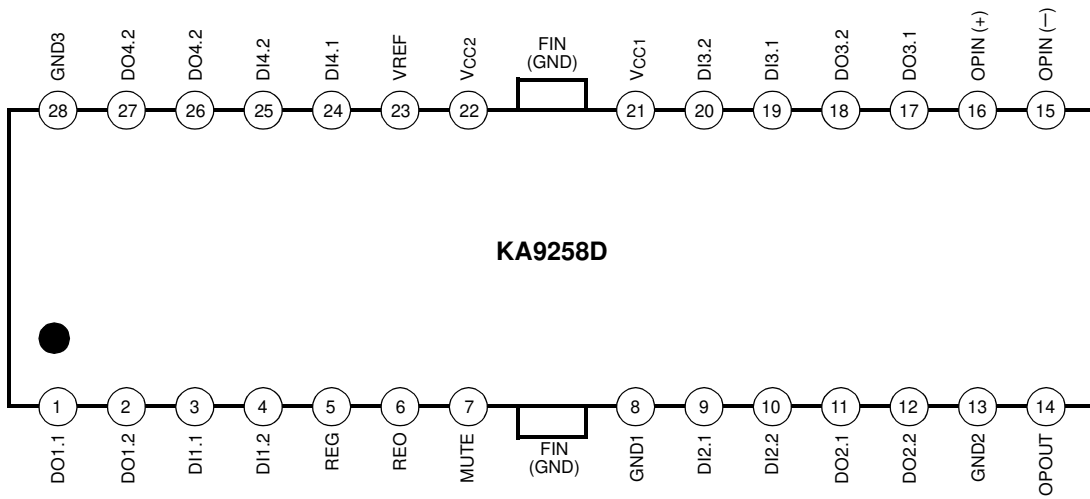

Pin Definitions

Pin Number	Pin Name	I/O	Pin Function Description
1	DO1.1	O	Drive Output
2	DO1.2	O	Drive Output
3	DI1.1	I	Drive Input
4	DI1.2	I	Drive Input
5	REG	-	Regulator
6	REO	O	Regulator Output
7	MUTE	I	Mute
8	GND1	-	Ground 1
9	DI2.1	I	Drive Input
10	DI2.2	I	Drive Input
11	DO2.1	O	Drive Output
12	DO2.2	O	Drive Output
13	GND2	-	Ground 2
14	OPOUT	O	OP-AMP Output
15	OPIN(-)	I	OP-AMP Input (-)
16	OPIN(+)	I	OP-AMP Input (+)
17	DO3.1	O	Drive Output
18	DO3.2	O	Drive Output
19	DI3.1	I	Drive Input
20	DI3.2	I	Drive Input
21	VCC1	-	Supply Voltage
22	VCC2	-	Supply Voltage
23	VREF	I	2.5V Bias Voltage
24	DI4.1	I	Drive Input
25	DI4.2	I	Drive Input
26	DO4.1	O	Drive Output
27	DO4.2	O	Drive Output
28	GND3	-	Ground 3

Internal Block Diagram

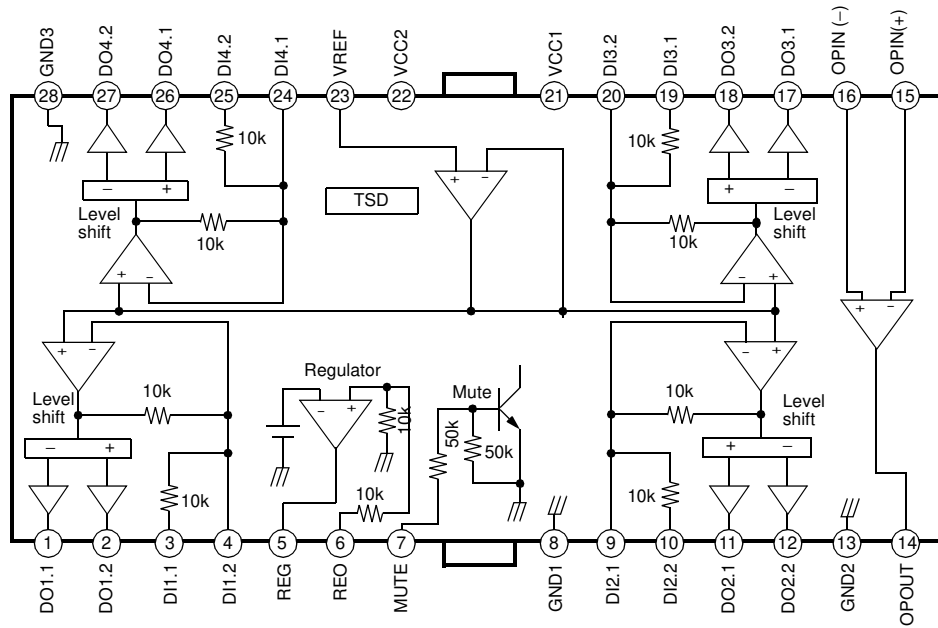

Equivalent Circuits

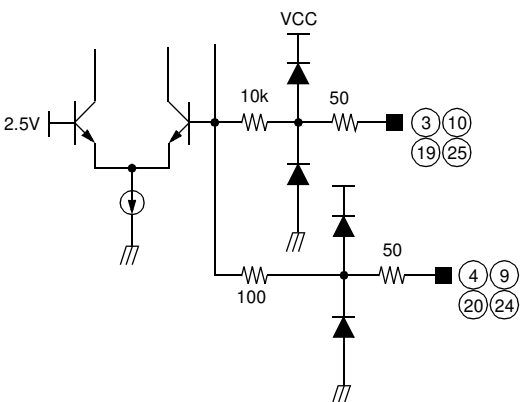
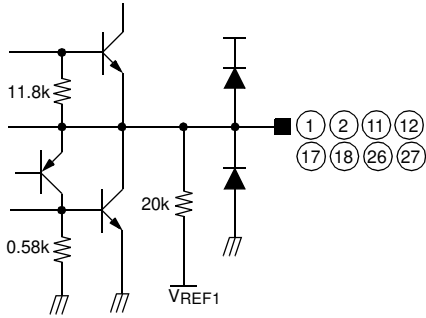
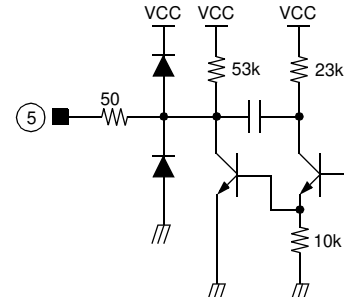
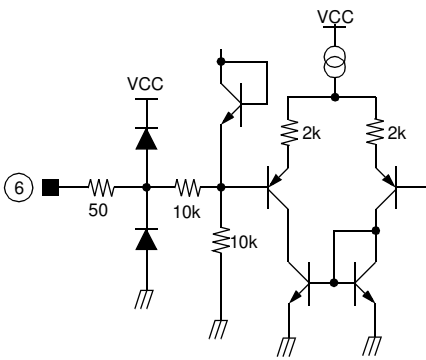
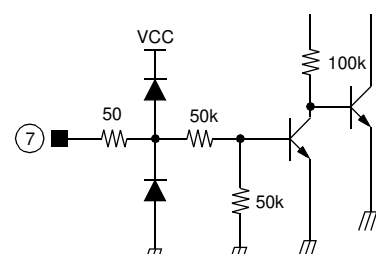
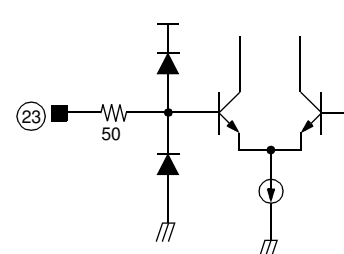
Driver Input	Driver Output
 <p>The Driver Input circuit features a 2.5V source connected to a network of transistors and diodes. A 10k resistor is connected to a node that branches to a 50 resistor leading to pins 3, 10, 19, and 25. Another 50 resistor leads to pins 4, 9, 20, and 24. A 100 resistor is connected to ground from the same node. The circuit is powered by VCC and includes several diodes for protection and signal conditioning.</p>	 <p>The Driver Output circuit is a push-pull stage. It includes a 11.8k resistor connected to a node that branches to pins 1, 2, 11, and 12. A 20k resistor is connected to this node and to a VREF1 input. A 0.58k resistor is connected to ground from the same node. The circuit is powered by VCC and includes several diodes for protection and signal conditioning.</p>
Regulator	Regulator Output
 <p>The Regulator circuit is a feedback loop. It starts with pin 5 connected to a 50 resistor. The circuit includes three VCC inputs, each with a diode to ground. Resistors of 53k and 23k are used for feedback. A 10k resistor is connected to ground. The circuit is powered by VCC and includes several diodes for protection and signal conditioning.</p>	 <p>The Regulator Output circuit is a push-pull stage. It starts with pin 6 connected to a 50 resistor. The circuit includes a VCC input with a diode to ground. Resistors of 10k and 10k are used for feedback. Two 2k resistors are connected to the output. The circuit is powered by VCC and includes several diodes for protection and signal conditioning.</p>
Mute Input	Bias Input
 <p>The Mute Input circuit starts with pin 7 connected to a 50 resistor. The circuit includes a VCC input with a diode to ground. Resistors of 50k and 50k are used for feedback. A 100k resistor is connected to the output. The circuit is powered by VCC and includes several diodes for protection and signal conditioning.</p>	 <p>The Bias Input circuit starts with pin 23 connected to a 50 resistor. The circuit includes a VCC input with a diode to ground. The circuit is powered by VCC and includes several diodes for protection and signal conditioning.</p>

Equivalent Circuits (Continued)

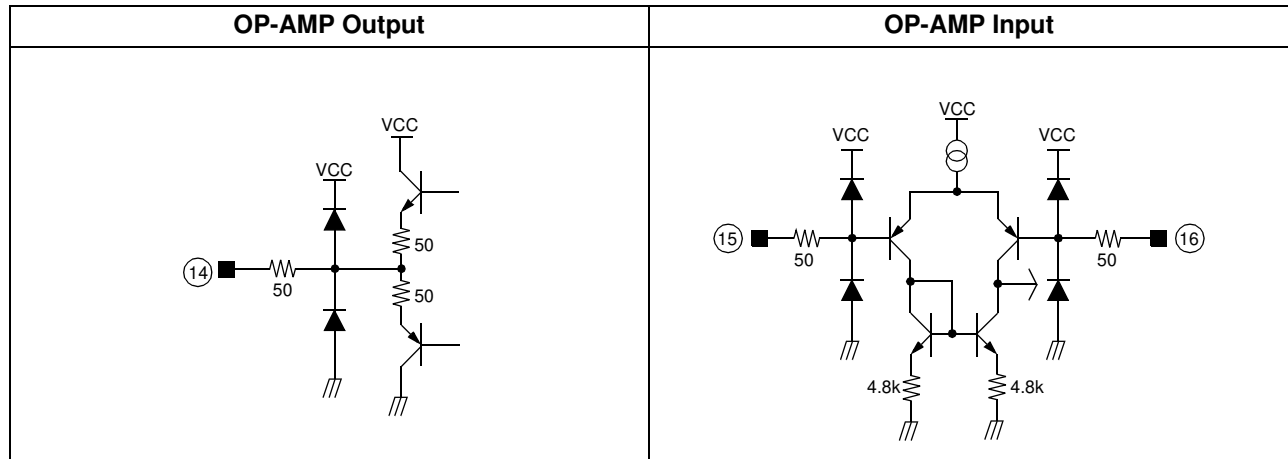

Absolute Maximum Ratings (Ta = 25°C)

Parameter	Symbol	Value	Unit
Supply Voltage	VCC	18	V
Power Dissipation	PD	1.7 ^{note}	W
Operating Temperature	TOPR	-40 ~ +85	°C
Storage Temperature	TSTG	-55 ~ +150	°C
Maximum Output Current	IOMAX	1	A

Note:

1. When mounted on 76.2mm × 114mm × 1.57mm PCB (Phenolic resin material).
2. Power dissipation reduces 13.6mW/°C for using above Ta=25°C
3. Do not exceed Pd and SOA (Safe Operating Area).

Power Dissipation Curve

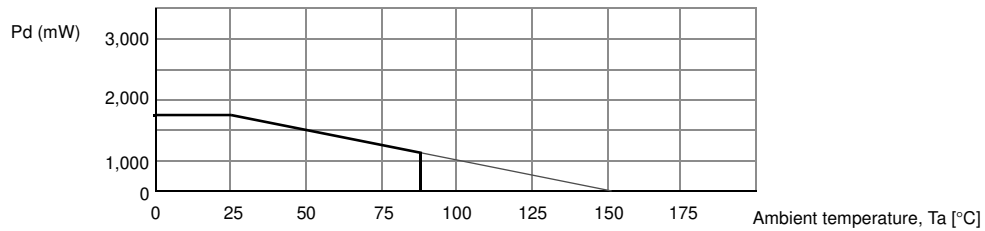

Recommended Operating Condition (Ta = 25°C)

Parameter	Symbol	Value	Unit
Operating Supply Voltage	VOPR	6 ~ 13.2	V

Electrical Characteristics (Ta = 25°C)

(Ta=25°C, VCC=8V, RL=8Ω, f=1kHz, unless otherwise specified)

Parameter	Symbol	Conditions	Min.	Typ.	Max.	Unit
REGULATOR PART						
Regulator Output Voltage	VREG	IL=100mA	4.75	5	5.25	V
Load Regulation	ΔVRL	IL=0 ~ 200mA	-40.0	0	10.0	mV
Line Regulation	ΔVCC	IL=200mA, VCC=6 ~ 9V	-10.0	0	20.0	mV
DRIVER PART (EXCEPT FOR LOADING MOTOR DRIVER)						
Quiescent Circuit Current	ICCQ	VI = 0	5.5	9.5	13.5	mA
*Input Offset Voltage	VOF	-	-5.0	0	5.0	mV
Output Offset Voltage	VOO	VCC= 13V	-50	0	50	
Maximum Sink Current	ISINK	RL= 4Ω, VCC	0.5	0.8	-	A
Maximum Source Current	ISOURCE	RL= 4Ω, GND	0.5	0.8	-	
Maximum Output Voltage	VOM	VI = 2VRMS, 1kHz	2.5	3.0	-	V
Closed Loop Voltage Gain	AVF	VI = 0.1VRMS, 1kHz	4.5	6.5	7.5	dB
*Ripple Rejection Ratio	RR	VI = -20dB, 120Hz	60.0	80.0	-	
*Slew Rate	SR	100Hz, Square wave	1.0	2.0	-	V/μs
LOADING MOTOR DRIVER PART (UNLESS OTHERWISE SPECIFIED, VCTL=OPENED)						
Input Offset Voltage	VOF1	-	-5	-	+5	mA
Input Bias Current	IB1	-	-	-	300	nA
High Level Output Voltage	VOH1	-	6	-	-	V
Low Level Output Voltage	VOL1	-	-	-	1.8	V
Output Sink Current	ISINK1	RL= 50Ω, GND	10	40	-	mA
Output Source Current	ISOURCE1	RL= 50Ω, VCC	10	50	-	mA
Open Loop Voltage Gain	GVO1	VIN = -75dB, f =1kHz	65	78	-	dB
*Ripple Rejection Ratio	RR1	VIN = -20dB, f =120kHz	50	70	-	dB
*Slew Rate	SR1	Square, VOUT = 2Vp-p, f = 120kHz	0.5	1	-	V/μs
Common Mode Rejection Ratio	CMRR1	VIN = -20dB, f =1kHz	70	84	-	dB

*Guranteed Design Value

Application Information

1. Mute

Pin #7	Mute circuit
High	Turn-off
Low	Turn-on
Open	Turn-on

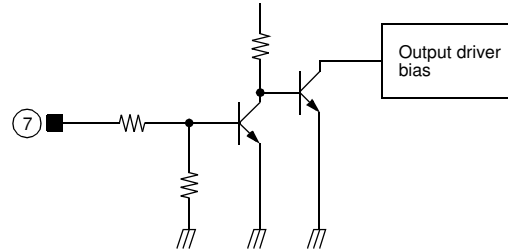

- When the mute pin #7 is open or the voltage of the mute pin #7 is below 0.5V, the mute circuit is activated so that the output circuit will be muted.
- When the voltage of the mute pin is above 2V, the mute circuit is disabled and the output circuit operates normal.
- If the chip temperature rises above 175°C, then the TSD (Thermal Shutdown) circuit is activated and the output circuit is muted.

2. Tsd (Thermal Shutdown)

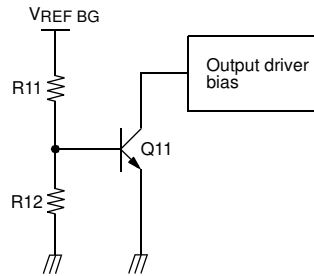

- The $V_{REF\ BG}$ is the output voltage of the band-gap-referenced biasing circuit and acts as the input voltage of the TSD circuit.
- The base-emitter voltage of the TR, Q11 is designed to turn-on at below voltage.

$$V_{BE} = V_{REF\ BG} \times R12 / (R11 + R12) = 460mV$$
- When the chip temperature rises up to 175°C, then the turn-on voltage of the Q11 would drop down to 460mV. (Hysteresis: 25°C)
 Hence, the Q11 would turn on so the output circuit will be muted.

3. OP-AMP

OP-amp is integrated in the IC for user's convenience.

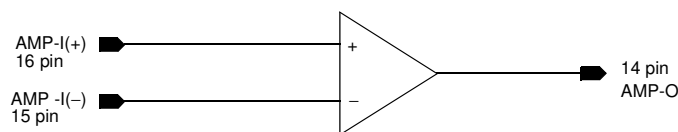

4. Driver

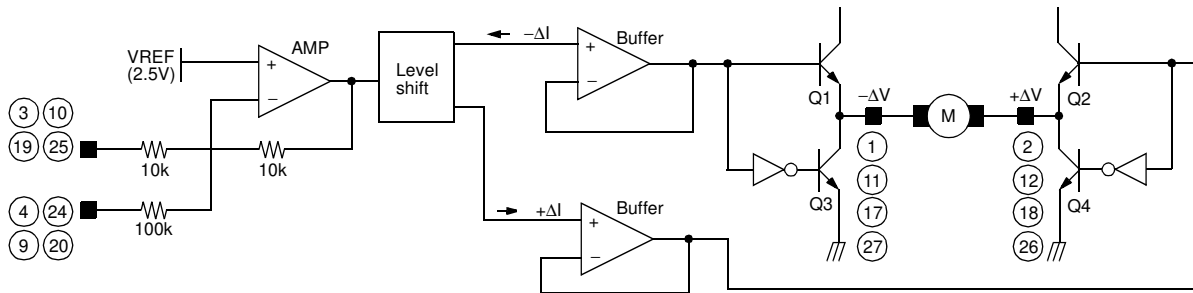

- The voltage, V_{REF} , is the reference voltage given by the bias voltage of the pin #23.
- The input signal through the pin #3 is amplified by 10k/10k times and then fed to the level shift.
- The level shift produces the current due to the difference between the input signal and the arbitrary reference signal. The current produced as $+\Delta I$ and $-\Delta I$ is fed into the driver buffer.
- Driver Buffer operates the power TR of the output stage according to the state of the input signal.
- The output stage is the BTL driver and the motor is rotating in forward direction by operating TR Q1 and TR Q4. On the other hand, if TR Q2 and TR Q3 is operating, the motor is rotating in reverse direction
- When the input voltage through the pin #3 is below the V_{REF} , then the direction of the motor in forward direction.
- When the input voltage through the pin #3 is above the V_{REF} , then the direction of the motor in reverse direction.
- If it is desired to change the gain, then the pin #4 or #24 can be used.

1. Connect a by-pass capacitor, 0.1 μ F between the supply voltage source.

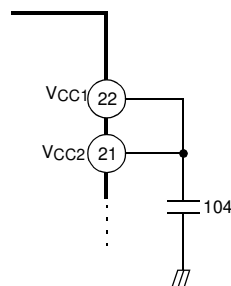

2. Radiation fin is connecting to the internal GND of the package. Connect the fin to the external GND.

Typical Performance Characteristics

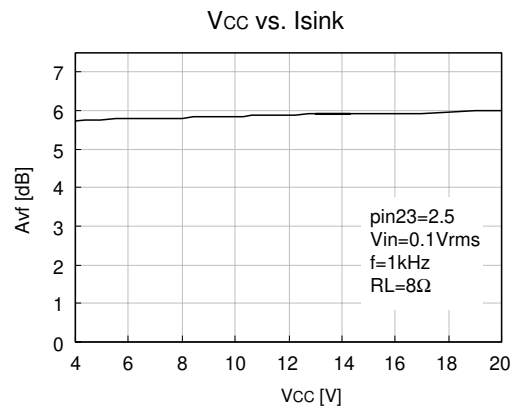
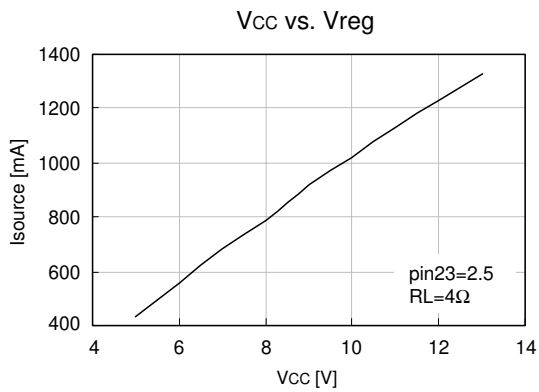
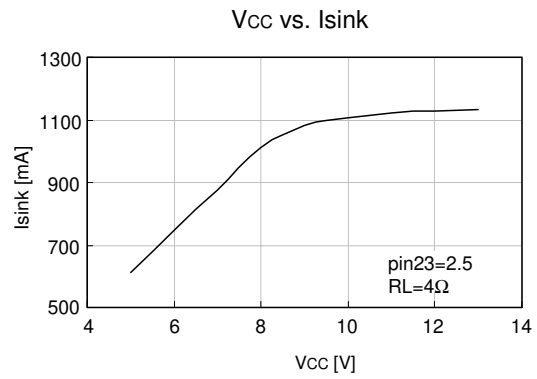
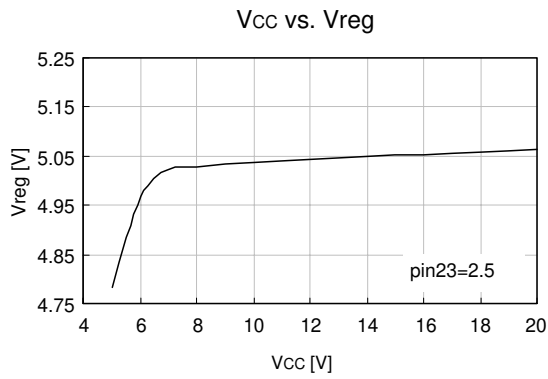
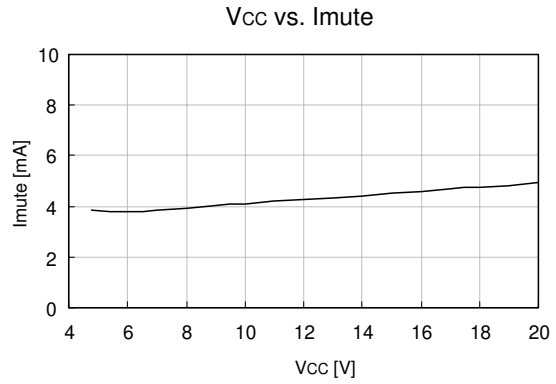
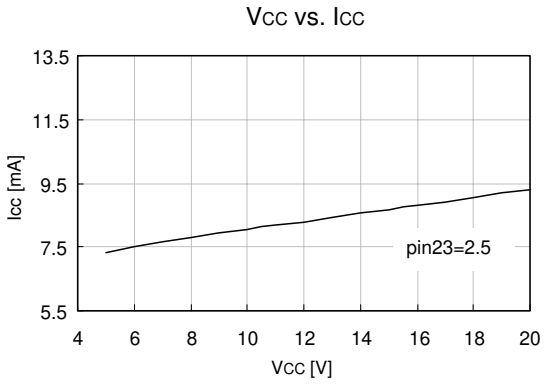

Typical Performance Characteristics (Continued)

Temp vs Icc

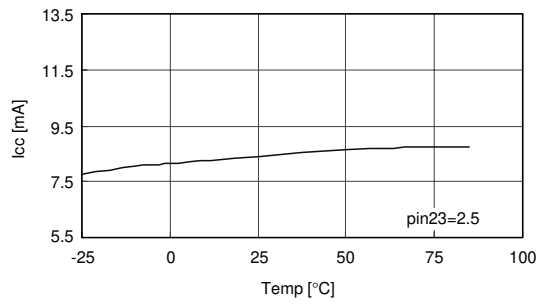

Temp vs Iccm

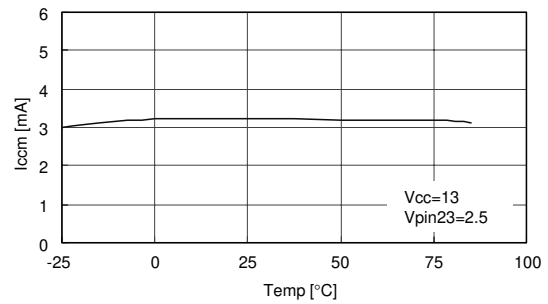

Temp vs Vreg

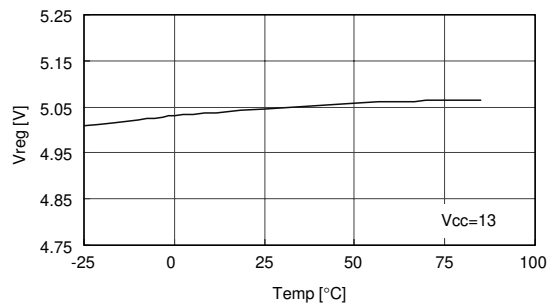

Temp vs Isource

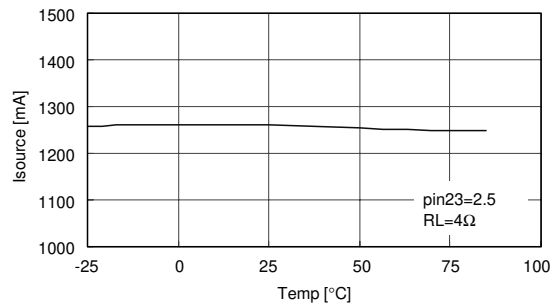

Temp vs Isink

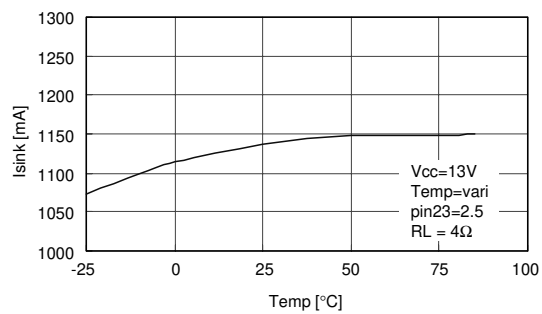

Test Circuits

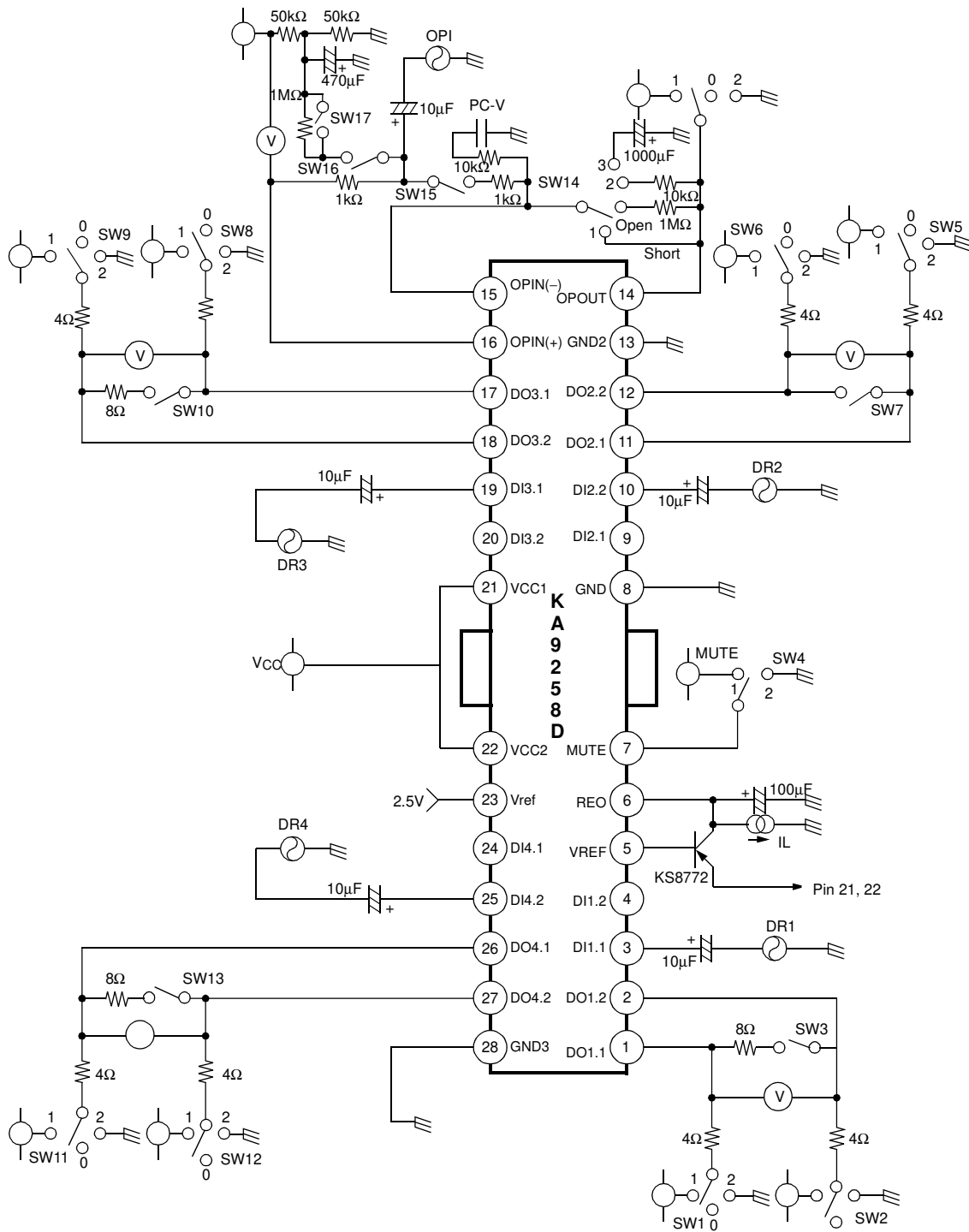

Application Circuits

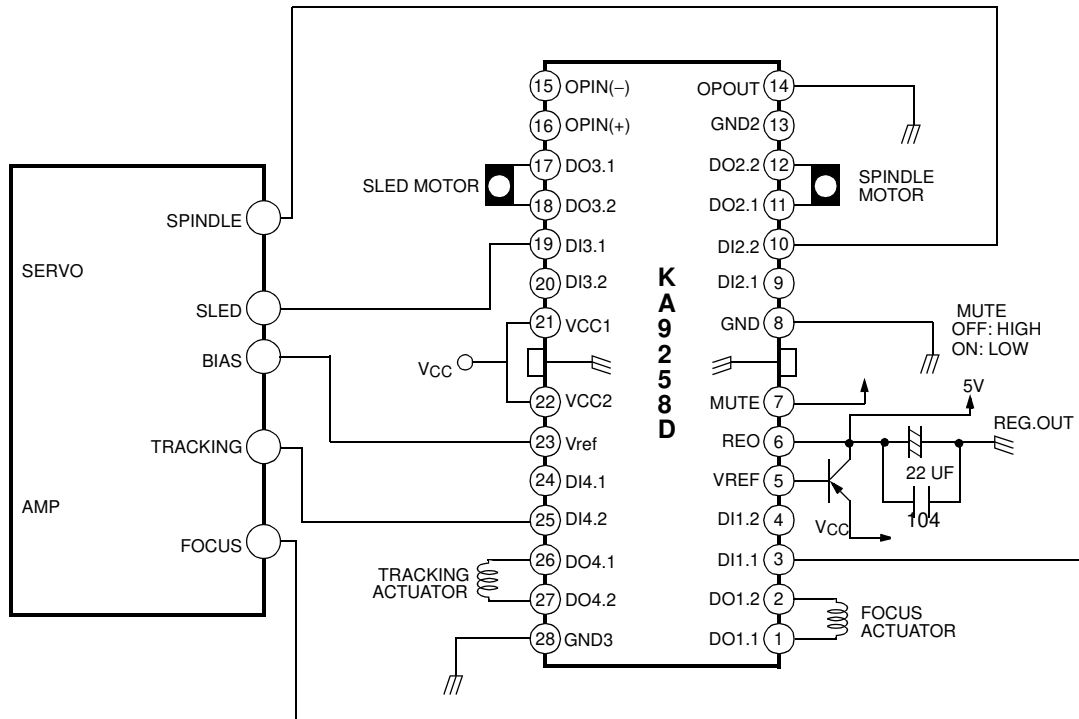

Thermal Shut Down Circuit

The IC breaks down by over heating when overload condition continues for a long time. KA9258D has built-in thermal shut down circuit to prevent this case. When IC temperature rises over 175°C, the circuit operates and protects the IC from breakdown.

DISCLAIMER

FAIRCHILD SEMICONDUCTOR RESERVES THE RIGHT TO MAKE CHANGES WITHOUT FURTHER NOTICE TO ANY PRODUCTS HEREIN TO IMPROVE RELIABILITY, FUNCTION OR DESIGN. FAIRCHILD DOES NOT ASSUME ANY LIABILITY ARISING OUT OF THE APPLICATION OR USE OF ANY PRODUCT OR CIRCUIT DESCRIBED HEREIN; NEITHER DOES IT CONVEY ANY LICENSE UNDER ITS PATENT RIGHTS, NOR THE RIGHTS OF OTHERS.

LIFE SUPPORT POLICY

FAIRCHILD'S PRODUCTS ARE NOT AUTHORIZED FOR USE AS CRITICAL COMPONENTS IN LIFE SUPPORT DEVICES OR SYSTEMS WITHOUT THE EXPRESS WRITTEN APPROVAL OF THE PRESIDENT OF FAIRCHILD SEMICONDUCTOR CORPORATION. As used herein:

1. Life support devices or systems are devices or systems which, (a) are intended for surgical implant into the body, or (b) support or sustain life, and (c) whose failure to perform when properly used in accordance with instructions for use provided in the labeling, can be reasonably expected to result in a significant injury of the user.
2. A critical component in any component of a life support device or system whose failure to perform can be reasonably expected to cause the failure of the life support device or system, or to affect its safety or effectiveness.