



**ZMOTIONL400ZCOG**

**zilog**®

---

A **Littelfuse** Company

**Z8F3224 ZMOTION  
Development Kit**

**User Manual**

**UM029501-0321**



**Warning:** DO NOT USE THIS PRODUCT IN LIFE SUPPORT SYSTEMS.

---

## LIFE SUPPORT POLICY

ZILOG'S PRODUCTS ARE NOT AUTHORIZED FOR USE AS CRITICAL COMPONENTS IN LIFE SUPPORT DEVICES OR SYSTEMS WITHOUT THE EXPRESS PRIOR WRITTEN APPROVAL OF THE PRESIDENT AND GENERAL COUNSEL OF ZILOG CORPORATION.

### As used herein

Life support devices or systems are devices which (a) are intended for surgical implant into the body, or (b) support or sustain life and whose failure to perform when properly used in accordance with instructions for use provided in the labelling can be reasonably expected to result in a significant injury to the user. A critical component is any component in a life support device or system whose failure to perform can be reasonably expected to cause the failure of the life support device or system or to affect its safety or effectiveness.

### Document Disclaimer

©2021 Zilog, Inc. All rights reserved. Information in this publication concerning the devices, applications, or technology described is intended to suggest possible uses and may be superseded. ZILOG, INC. DOES NOT ASSUME LIABILITY FOR OR PROVIDE A REPRESENTATION OF ACCURACY OF THE INFORMATION, DEVICES, OR TECHNOLOGY DESCRIBED IN THIS DOCUMENT. ZILOG ALSO DOES NOT ASSUME LIABILITY FOR INTELLECTUAL PROPERTY INFRINGEMENT RELATED IN ANY MANNER TO USE OF INFORMATION, DEVICES, OR TECHNOLOGY DESCRIBED HEREIN OR OTHERWISE. The information contained within this document has been verified according to the general principles of electrical and mechanical engineering.

Z8 Encore!, Z8 Encore! XP, ZMOTION™, eZ80Acclaim! and ZNEO are trademarks or registered trade- marks of Zilog, Inc. All other product or service names are the property of their respective owners.

## Overview

Zilog's Z8F3224 ZMOTION Development Kit provides a general-purpose platform for evaluating the capabilities and operation of the ZMOTION Engine Library using the Z8F3224 Series of microcontrollers. This kit is equipped with two Z8F3224 MCUs – one configured for *Low Power* operation and one configured for *Normal Power* operation and comes complete with various lenses to test the ZMOTION Engine Library for multiple applications.

Zilog's ZMOTION Engine Library provides an integrated and flexible solution for Passive Infra-Red (PIR)-based motion detection applications. The Software library is comprised of the PIR sensor signal processing algorithms for motion detection, transient and noise detection, white light detection, and several other motion-related functions to be integrated with the user's application code.

An Application Programming Interface (API) allows the application code to configure, control, and monitor the Library in real time. API configuration parameters allow the Engine operation to be optimized for the particular lens and pyro electric sensor being used in the application. This allows the designer to create their own application-specific software while taking advantage of Zilog's ZMOTION Motion Detection technology.

For more information about the operation of the ZMOTION Library, refer to [ZMOTION Engine User Manual \(UM0275\)](#).

## Kit Contents

The Z8F3224 ZMOTION Development Kit includes the components listed in the following table.

Item	Description	Quantity
1	Z8F3224 ZMOTION Development Board	1
2	Encore! Smart Cable or USB Smart Cable	1
3	Lenses: ZCWM05GIV1, ZNCL11, ZNCL926, ZNCL10IL, ZNCL3B, ZNCL10R, ZNCL10S	7
4	USB Cable - type A/B	1

**Table 1. Kit Contents**



Figure 1. ZMOTIONL400 Development Kit Contents

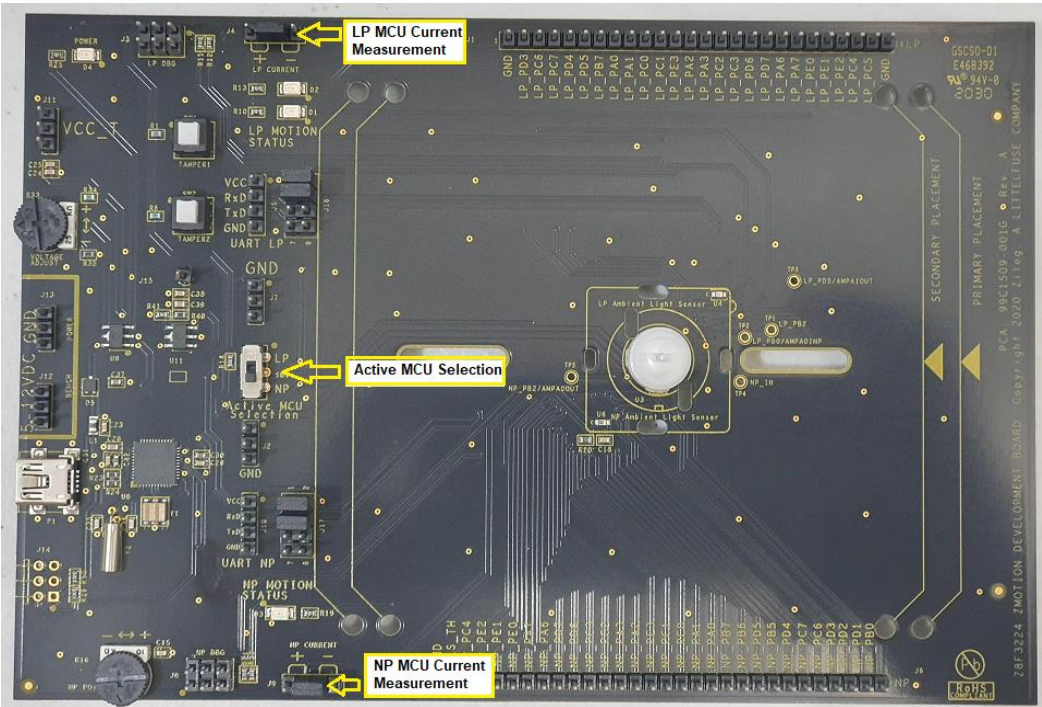

Figure 2. Development Board (top side)

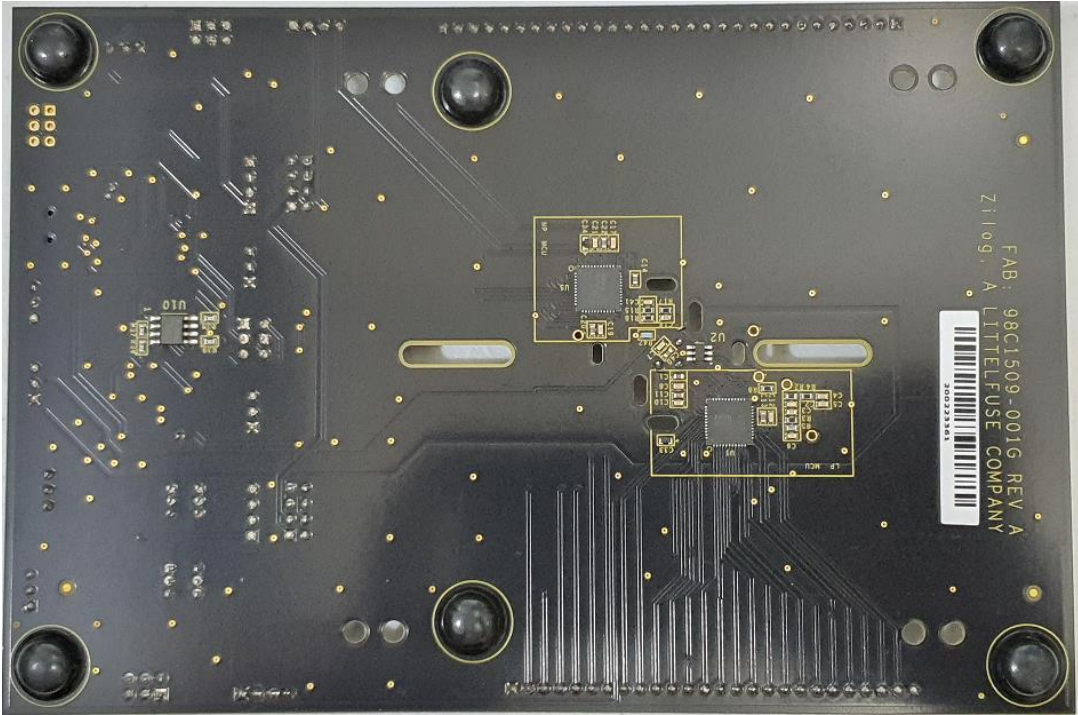

Figure 3. Development Board (bottom side)



## Lenses

The Development Kit includes seven lenses. Two mounting options are supported – Clip on and PCB Mount. The following tTable 2 describes the lenses that are included with the Kit.







Part Number	Description	Typical Applications
<b>ZNCL10IL</b> 	9mm Wall Mount 80°x30° Clips on to pyroelectric sensor 6 beams (X); 2 beams (Y) 7m range	Wall mount for power management <ul style="list-style-type: none"> <li>• Proximity or entrance detection</li> <li>• Kiosks/Vending</li> <li>• Product display's</li> </ul>
<b>ZNCL3B</b> 	9mm Wall/Ceiling Mount (60°x60°) Clips on to pyro-electric sensor 4 beams (X); 2 beams (Y) 3m range	Proximity or entrance detection <ul style="list-style-type: none"> <li>• Kiosk/Display Counters</li> <li>• Vending</li> <li>• HVAC</li> </ul>
<b>ZNCL10R</b> 	9mm Wall/Ceiling Mount (circular 360°) Clips on to pyro-electric sensor 90° Cone 14 zones with dual pyro 5m range	Room Occupancy and Proximity Sensing <ul style="list-style-type: none"> <li>• Lighting and HVAC Control</li> <li>• Kiosk/Display Control</li> <li>• Vending/Appliance Power Management</li> </ul>
<b>ZNCL10S</b> 	9mm Wall/Ceiling Mount (15°x15°) Clips on to pyro-electric sensor 2 beams (X); 1 beam (Y) 12m range	Barrier or entrance detection <ul style="list-style-type: none"> <li>• Kiosk/Display Counters</li> <li>• Vending</li> <li>• HVAC</li> <li>• Directional detection</li> </ul>
<b>ZNCL926</b> 	Clip-on 15mm (360°) 26 Segments 5m height, 2.1:1 Floor diameter to height ratio	Room Occupancy and Proximity Sensing <ul style="list-style-type: none"> <li>• Lighting and HVAC Control</li> <li>• Kiosk/Display Control</li> <li>• Vending/Appliance Power Management</li> </ul>
<b>ZNCL11</b> 	Wall/Ceiling Mount 104°(X), 37°(Y) Circuit board mount Black rectangular lens with flat front 32 detection zones 4m range	Wall or ceiling mount for power management <ul style="list-style-type: none"> <li>• Room occupancy and proximity sensing</li> <li>• Power management</li> <li>• Display power management</li> </ul>
<b>ZCWM05GIV1</b> 	Ceiling/Wall Mount Array (360°/180°) Circular lens with 24mm x 24mm square base Board mount clip-in 9m height/range	Wall or ceiling mount for office or meeting room lighting and HVAC control <ul style="list-style-type: none"> <li>• Room Lighting Control</li> <li>• Local HVAC Control</li> </ul>

Table 2. Lenses Included with Kit

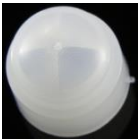
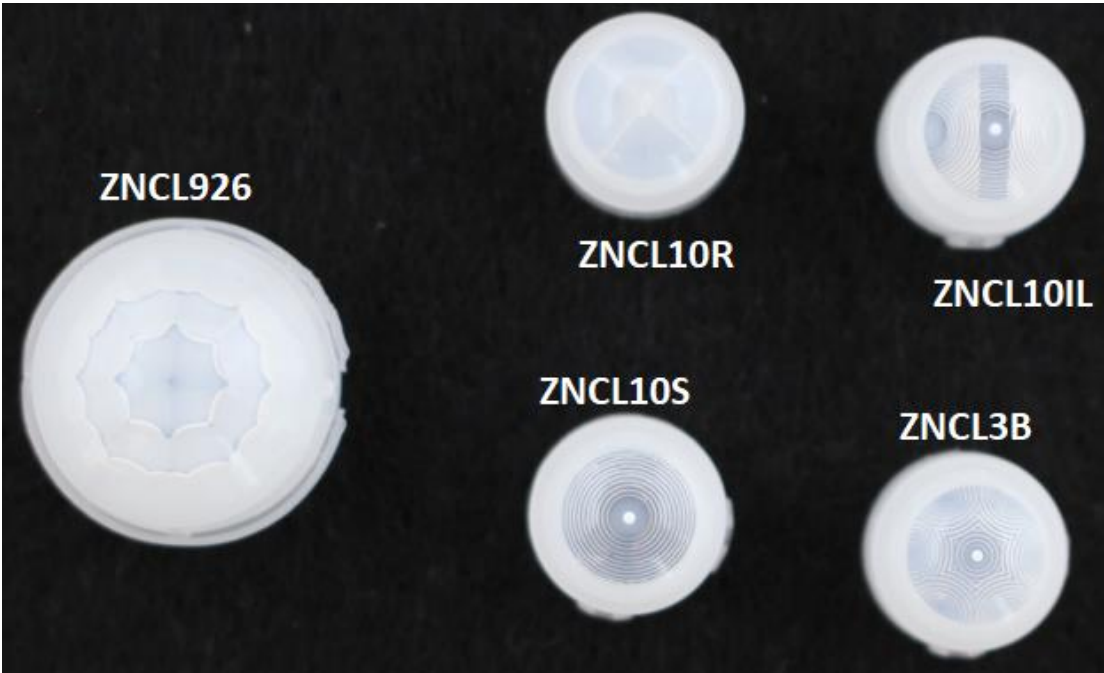

Figure 4. Clip-on Lenses



Figure 5. ZNCL11 – PCB Mount

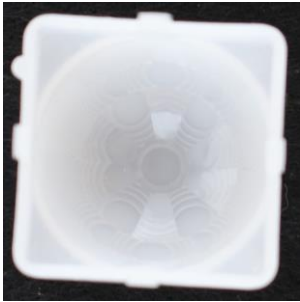

Figure 6. ZCWM05GIV1 – PCB Mount

# Z8F3224 ZMOTION Development Board

This section describes the components of the ZMOTION Development Board.

## Features

- Two Z8F3224QN020XK2258 ZMOTION MCU's
  - Normal Power configuration
  - Low Power configuration
- USB Serial Interface
- Tamper switches
- Ambient Light Sensors
- Status LED's
- Variable power supply 2.0V to 3.5V

The following figure shows a block diagram of the Z8F3224 ZMOTION Development Board. Refer to Appendix A for the complete schematic diagrams.

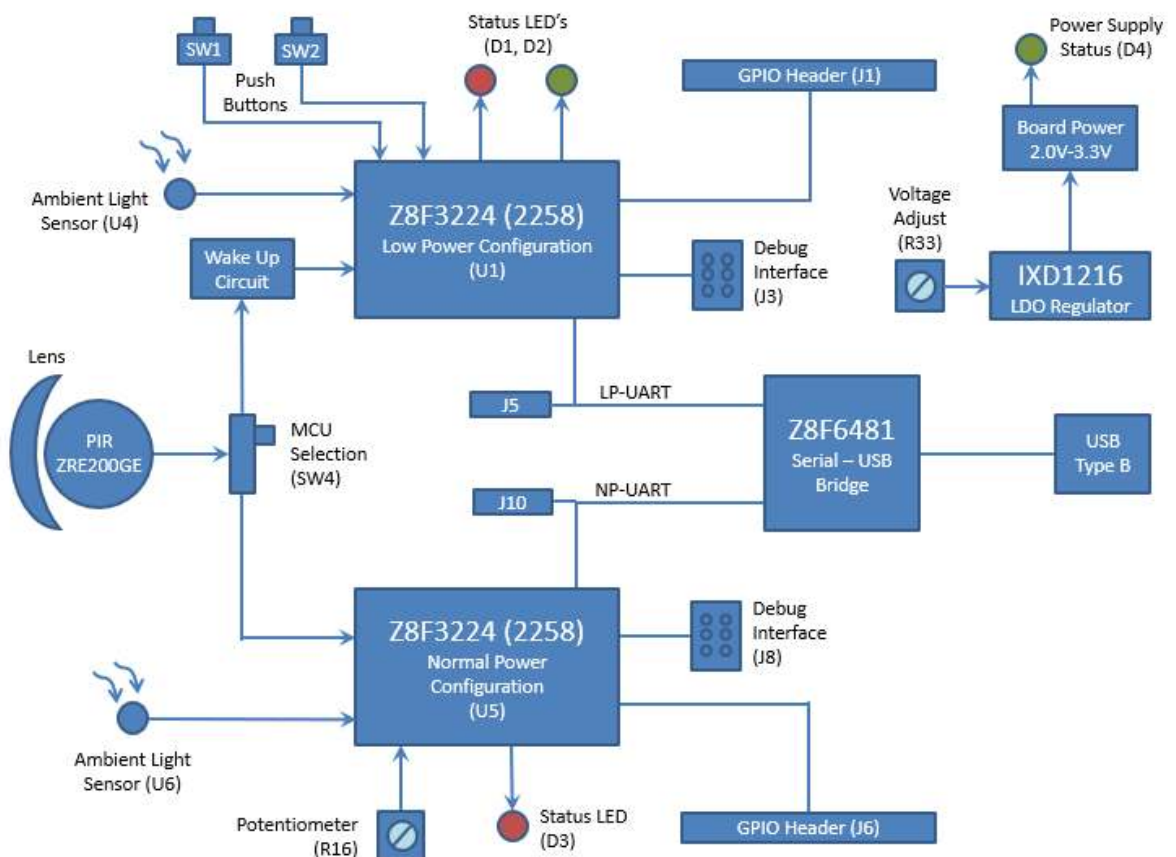

Figure 7. Z8F3224 ZMOTION Development Board Block Diagram



# The Z8F3224 ZMOTION MCU

The ZMOTION Library requires a special version of the Z8F3224 Series device. Devices that support the ZMOTION Library include a 2258 suffix on the part number. There are three devices available that support the ZMOTION Library, as listed in the following table.

MCU Part Number	Package	Memory
* Z8F3224QN020XK2258	44-Pin QFN	32KB Flash, 3.75KB RAM
Z8F3224QK020XK2258	32-Pin QFN	32KB Flash, 3.75KB RAM
Z8F3224HH020XG2258	20-Pin SSOP	32KB Flash, 3.75KB RAM

**Table 3. Z8F3224 Series Devices Supporting the ZMOTION Library**

\* The Z8F3224QN020XK2258 (44-Pin QFN) is provided with the development kit.

## MCU Features

- 20 MHz eZ8 CPU core
- 16 KB or 32 KB Flash memory with in-circuit programming capability
- 3.75KB internal RAM
- Up to 15-Channel, 12-bit Analog-to-Digital Converter (ADC) that can be configured for internal or external voltage reference and single-ended or differential inputs
- Two on-chip analog comparators
- Two on-chip, low-power operational amplifiers
- 8 Channel Event System provides communication between peripherals for autonomous triggering
- Full-duplex 9-bit UART port with the support of Local Interconnect Network (LIN) and Digital Addressable Lighting Interface (DALI) protocols. RS-485 Multidrop Mode up to 250 kbit/sec (DMX Support) integrated with UARTs
- Enhanced Serial Peripheral Interface (SPI) controller
- I2C controller which supports Master/Slave modes
- One 16-bit timer with 3 functional modes
- Three enhanced 16-bit timers with Capture, Compare, and PWM capability
- One additional basic 16-bit timer with interrupt (shared as UART Baud Rate Generator)
- 16-bit Multi-Channel Timer which supports four Capture/Compare/PWM modules (not available on 20, 32-pin packages)
- Watchdog Timer (WDT)
- 14 to 36 General-Purpose Input/Output (GPIO) pins, depending upon package

- Up to 30 interrupt sources with up to 23 interrupt vectors
- On-Chip Debugger (OCD)
- Power-On Reset (POR) and Voltage Brown-Out (VBO) protection
- Built-in Low-Voltage Detection (LVD) with programmable voltage threshold
- Low Frequency Crystal Oscillator (LFXO) operating at 32.768 kHz with low power consumption
- Internal clock sources and clock multiplication including: Internal Precision Oscillator (IPO), Digitally Controlled Oscillator (DCO), Watchdog Timer Oscillator (WTO) and Frequency Locked Loop (FLL)
- Wide operation voltage range: 1.8 V–3.6 V
- 20-, 32-, and 44-pin packages
- –40°C to +85°C (extended) operating temperature range

## Getting Started

Download and install the ZMOTIONL400ZCOG\_1.0 installation file from the [Zilog website](#) located at the Software Download > Software Development Software. This will create a folder that includes the VCOM USB driver, reference schematics, sample applications, ZMOTION Engine Library, and related documentation. Version 1.0 is the latest version of the installation file when the kit was released. Later versions of the file may be available.

After installation the following folders will be created:

```
\Zilog\ZMOTIONL400ZCOG_1.0
  Documentation
  Drivers
  Z8F3224 ZMOTION Library
    Reference Schematics
    Sample Applications
    ZMOTION Engine Library
```

The development board comes with two Z8F3224QN020XK2258 MCUs that are pre-programmed with sample applications to demonstrate basic motion detection. These projects, and others are included in the Sample Applications folder.

- The LP MCU is pre-programmed with the ZM\_LP\_Basic application.
- The NP MCU is pre-programmed with the ZM\_NP\_Basic application.

---

**Note:** The 2258 suffix is a specific version of the Z8F3224 MCU series that supports the ZMOTION Library. Devices without the 2258 suffix do not support the ZMOTION Library

---

The MCU's share the same PIR sensor, so only one device may be used at a time. SW4 (Active MCU Selection) is used to select the active MCU. The unselected MCU is powered off.

- The LP MCU is in the Low Power configuration.
- The NP MCU is in the Normal Power configuration.

For a demonstration with the pre-programmed application, perform the following steps:

1. Install the VCOM USB driver included with the ZMOTIONL400ZCOG\_1.0 installation file by right-clicking on the .exe file and selecting Run as administrator. This driver is located in the Drivers folder.
  - Zilog\_VCOM\_Install.x64.exe: 64-bit Windows
  - Zilog\_VCOM\_Install.x86.exe: 32-bit Windows
  - The Device Driver will be installed as (Zilog USB Serial Device) in Device Manager under Ports (COM & LPT)
2. Set SW4 to select the active MCU configuration (LP or NP).
3. Install the ZNCL10IL lens on the PIR sensor.
4. Ensure that each jumper is installed for J4 (2:3 shunt) and J9 (2:3 shunt). Active device is enabled on SW4.
5. Ensure that R16 is adjusted on a fully clockwise direction. This shall allow NP\_VDD\_IN to have the same voltage level as VCC\_T.
6. With the USB A (male) to Mini-B cable, connect Port P1 on the Development Board to a USB port on the development PC or other suitable power source to apply power to the Development Board.
  - Alternatively, power can be supplied from a bench type power supply using J12 and J13. An input of 5V to 12V is supported.

When power is first applied, the status LED will blink until the PIR sensor is stable. When the PIR sensor is stable, the status LED will turn off and blink when motion is detected.

If the USB interface is connected to a PC, a terminal emulation program like RealTerm or CoolTerm can be used to observe the motion status events. Set the serial interface to 57600bps, N, 8, 1.

Refer to the [Sample Applications](#) section to learn more about specific MCU operations.

## MCU Current Measurement

The MCU current consumption can be easily measured by removing the shunt on J4 (LP Current) or J9 (NP Current) and connecting an ammeter on the respective positive (+) and negative (-) header pins.

## Operating Voltage Adjustment

The MCU operating voltage can be adjusted from 2.0V to 3.5V by the R33 potentiometer. Turn the potentiometer clockwise to decrease the voltage. The operating voltage can be measured from the J11 header (labeled VCC\_T).

## UART Interface

The MCU UART can be connected to the Serial to USB converter (U8) and/or directly available as TTL signals via J10 (NP MCU) or J5 (LP MCU). Use the jumpers on J17 (NP MCU) and J16 (LP MCU) to select the desired connection.

LP UART Connection	Txd (J16)	Rxd (J16)
J5 Header	7-8	5-6
USB (U8)	3-4	1-2

Table 5. LP MCU UART Connections

NP UART Connection	Txd (J17)	Rxd (J17)
J10 Header	7-8	5-6
USB (U8)	3-4	1-2

Table 4. NP MCU UART Connections

Use caution when using a separate Serial to USB converter cable connected to J10 or J5. The Z8F3224 supply voltage (VCC\_T) selected by R33 must match the drive level provided by the cable. The sample applications provided avoid this issue as follows:

- Txd: Configured as Open Drain without an internal pull up. The pull up resistor should be provided on the Rxd (cable) side.
- Rxd: Internal pull-up resistor connected to VCC\_T is enabled. The Txd side (cable side) should drive using Open Drain.
- The Serial to USB chip (U8) on the ZMOTIONL400 board is configured in this manner.
- Failing to follow this precaution can cause unexpected behaviour and inaccurate current measurement reading through J9 (NP MCU) or J4 (LP MCU).

## Sample Applications

Table 6 lists four sample application projects that are included with the ZMOTIONL400ZCOG\_1.0 installation file. Contact [Zilog Technical Support](#) for additional sample projects.

The LP and NP MCUs on the Development Board come preloaded with the ZM\_LP\_Basic and ZM\_NP\_Basic projects. To load a different project, refer to the [Using ZDS-II to Debug a Project](#) section on page 16.

Project	Folder	MCU Configuration
ZM_LP_Basic	ZMOTION_LP_Basic	Low Power
ZM_LP_Command	ZMOTION_LP_Command	Low Power
ZM_NP_Basic	ZMOTION_NP_Basic	Normal Power
ZM_NP_Command	ZMOTION_NP_Command	Normal Power

**Table 6. Sample Applications**

The Z8 Encore! family of MCUs supports three operating modes:

- Run – In this mode, the CPU is running and all peripherals/clock sources can be enabled (normal running mode).
- Halt – In this mode, the CPU is not running and all peripherals/clock sources can be enabled. Exit via interrupt.
- Stop – In this mode, the CPU is not running and some peripherals/clock sources can be enabled. Exit via Stop Mode Recovery (SMR).

Stop mode provides the lowest current consumption and is used in the ZM\_LP\_Basic and ZM\_LP\_Command projects. The ZM\_NP\_Basic and ZM\_NP\_Command projects use Halt mode to reduce current consumption.

However, debugging operations are limited when using Stop mode. To use the full debugger with the ZM\_LP\_Basic and ZM\_LP\_Command projects, the following configuration definition is included in the `Sleep.h` file that enables the use of Halt mode in place of Stop mode.

```
#define USE_STOP_MODE
```

Set this definition to 0 and rebuild the project before to use Halt mode in place of Stop mode. Set this definition to 1 to use Stop mode. Current consumption will be higher when using Halt mode.

## Sample Application Projects

There are four sample application projects included with the ZMOTIONL400ZCOG\_1.0 installation.

- [ZM\\_LP\\_Basic](#)
  - Basic motion detection operation in Low Power Mode
- [ZM\\_LP\\_Command](#)
  - Advanced motion detection operation in Low Power Mode
  - Refer to “Serial Command Functions LP Rev x.pdf” included in the project folder
- [ZM\\_NP\\_Basic](#)
  - Basic motion detection operation in Normal Power Mode
- [ZM\\_NP\\_Command](#)
  - Advanced motion detection operation in Normal Power Mode
  - Refer to “Serial Command Functions NP Rev x.pdf” included in the project folder

### ZM\_LP\_Basic

This project uses the Low Power MCU configuration to provide motion detection with ZMOTION Digital PIR validation.

The MCU stays in Low Power Stop mode until a motion event is detected by the analog PIR interface. When the MCU wakes up it runs the ZMOTION Engine on the PIR signal to validate the motion event.

When the motion event is validated, the status LED is flashed, and a message is sent via the VCOM USB serial interface (connected to UART0 on the LP MCU).

Typical current consumption is <15uA @ 3.3V

Sliding SW4 to the LP position causes the NP MCU to be powered off and powers on the LP MCU. The following status messages will be displayed on the terminal after power on.



```

Z8F3224 ZMOTION Low Power Sample Program
ZM_LP_Basic
Version: 1.3

DEBUG_STATE: 1

Sleep State: Stop Mode
ZMOTION: Enabled
Analog Wake Up Sensitivity Level: 2
ZMOTION Validation Sensitivity Level: 9
Pet Immunity: OFF
Ambient Light Gate: Disabled
LED On Time (ms): 500
Motion Delay Time (s): 2.0
Motion Trigger Time (ms): 50
Input Change Detection:
    SW1: Enabled
    SW2: Enabled

Waiting for PIR Stability (30 seconds)...
.*0004.
.*0004.
.*0004.
.*0004.
.*0004.
.*0004.
.*0004.
.*0004.
.*0004.
.*0004.

```

Figure 8. ZM\_LP\_Basic Power on Messages

The MCU normally stays in Stop mode to conserve power. Each time it wakes up, a status message is sent to indicate the reason for the wake up. Table 7 lists these status message descriptions.

Status Code	Description
*0004	Wake up from Power-on Stability Delay timer.
*0002	Wake up from Ignore Motion Timer
*0001	Wake up due to analog PIR motion event
*0010	Wake up to drive Motion Trigger Output inactive
PIR Stable	PIR sensor is stable – Power on stability delay complete.
Motion Detected	The ZMOTION Engine validated the motion event.
EM	Motion detection enabled – Ignore Motion time is complete
SW1 Pressed	Indicates that Tamper1/SW1 is pressed down
SW1 Released	Indicates that Tamper1/SW1 is pressed to release the switch up
SW2 Pressed	Indicates that Tamper2/SW2 is pressed down
SW2 Released	Indicates that Tamper2/SW2 is pressed to release the switch up
.	MCU has entered Sleep mode

Table 7. Status Messages

**Note:** In Table 7, '\*' indicates MCU wake up and '.' indicates MCU returning to Stop mode. When Motion Detected status is sent, an ASCII BELL character (0x07) is also sent. Some terminal applications can interpret this and provide an audible indication of motion detection

## ZM\_LP\_Command

This project uses the Low Power MCU configuration to provide motion detection with ZMOTION Digital PIR validation.

The MCU stays in Low Power Stop mode until a motion event is detected by the analog PIR interface. When the MCU wakes up it runs the ZMOTION Engine on the PIR signal to validate the motion event.

When the motion event is validated, the status LED is flashed, motion trigger output is pulsed, and a message can be sent via Serial interface.

Typical current consumption is <15uA @ 3.0V.

The serial command interface has the following features that help adjust system operations and performance:

- Pet Immunity mode
- Programmable Digital and Analog sensitivity
- Programmable LED, trigger, and motion delay time
- Ambient light levels and threshold
- Temperature Compensation – adjusts Analog PIR thresholds based on ambient temperature
- Temperature Change Protection – Ignores motion events generated by temperature changes
- Vdd Shift Protection – Ignores motion events generated by shifts in supply voltage
- Smart Sense Mode – Intelligent micro motion
- Pass Through Mode – Intelligent motion delay time
- Boot Loader

Refer to the “Serial Command Functions LP” file included with the project for a full description of operation and list of functions and features.

## ZM\_NP\_Basic

This project demonstrates the use of the ZMOTION Library and API to detect motion. In Normal Power mode, the MCU is continuously sampling and processing the PIR sensor signal.

When motion is detected, an LED is turned on, output is driven active, and a message is sent via the VCOM USB serial interface (connected to UART0 on the NP MCU).

Typical current consumption is <1mA @ 3.0V

Move SW4 from the LP position to the NP position. The LP MCU will be powered off. The NP MCU will start running and display the following messages:

```

Z8F3224 ZMOTION Library Sample Program
ZM_NP_Basic
Version: 2.2

USE_DEBUG_STATE: 1

Motion Sensitivity Level: 8
Pet Immunity: OFF
Motion Delay Time (s): 1.5
Motion Trigger Time (s): 30.0
Ambient Light Gating: Enabled
- Use Potentiometer R16 to set threshold

Waiting for PIR Sensor Stability
*****
PIR Stable
  
```

Figure 9. ZM\_NP\_Basic Power on Messages

Each time the MCU wakes up from a motion event it will display the following status message:

```

Motion Detected
Motion Detected
Motion Detected
Motion Detected
Motion Detected
Motion Detected
  
```

Figure 10. ZM\_NP\_Basic Motion Detection Messages

## ZM\_NP\_Command

This project demonstrates the use of the ZMOTION Library and API to detect motion with ambient light detection and a serial command interface. When a motion event is detected, the status LED is flashed, motion trigger output is pulsed, and a message can be sent via Serial interface.

Typical current consumption is <1mA @ 3.0V

The serial command interface includes the following features that help adjust system operations and performance:

- Pet Immunity mode
- Programmable Digital sensitivity
- Programmable LED, trigger, and motion delay time
- Ambient light levels and threshold
- Temperature Compensation – adjusts Analog PIR thresholds based on ambient temperature
- Temperature Change Protection – Ignores motion events generated by temperature changes
- Vdd Shift Protection – Ignores motion events generated by shifts in supply voltage
- Smart Sense Mode – Intelligent micro motion
- Pass Through Mode – Intelligent motion delay time
- Boot Loader

Refer to the Serial Command Functions NP file included with the project for a full list of functions and features.

## Using ZDS-II to Debug a Project

Zilog Developer Studio II (ZDS II) Integrated Development Environment is a complete standalone system that provides a state-of-the-art development environment. Based on standard Windows user interfaces, ZDS II integrates a language-sensitive editor, project manager, C-compiler, assembler, linker, librarian, and source-level symbolic debugger to provide a development solution specifically tailored to the Z8 Encore! Family of microcontrollers.

1. Download and install ZDS II using the procedure outlined in [Appendix B. IDE- Zilog Developer Studio II](#).
2. If not already installed, install the VCOM USB driver included with the ZMOTIONL400ZCOG\_1.0 installation file by right-clicking on the .exe file and selecting **Run as administrator**. This driver is located in the Drivers folder.
  - Zilog\_VCOM\_Install.x64.exe: 64-bit Windows
  - Zilog\_VCOM\_Install.x86.exe: 32-bit Windows
  - The Device Driver will be installed as (Zilog USB Serial Device) in Device Manager under Ports (COM & LPT)

## Connect ZMOTIONL400 Dev Board and PC

Observe the following procedure to connect the ZMOTIONL400 Development Board to your PC. We will use the ZM\_NP\_Command project for this example.

---

**⚠ Caution:** Disconnect or turn off the power to the ZMOTIONL400 Development Board before connecting or disconnecting the Encore! SmartCable or the USB Smart Cable.

---

1. Ensure that the NP Current Jumper is installed on J9. It should be installed across the centre two pins, as shown in the following figure.

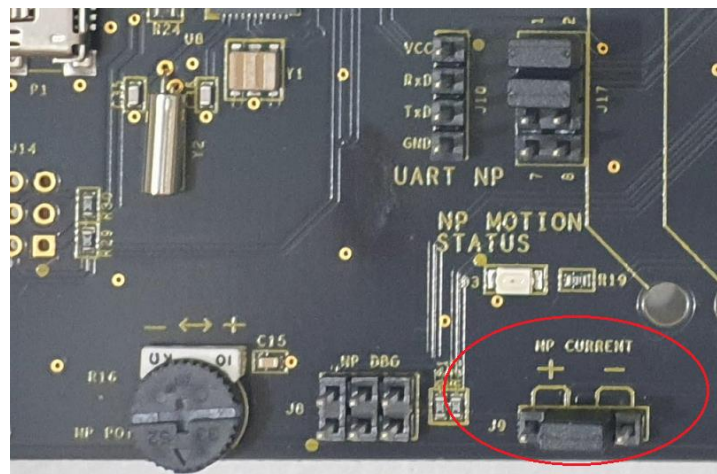

Figure 11. NP Current Jumper Installed on J9

2. Place switch SW4 into the NP position.
3. Connect one end of the 6-circuit ribbon cable provided in your Kit to the SmartCable debugger, ensuring that the ribbon's male connector is aligned correctly with the female connector on the unit, as indicated by the red stripe in the following figure.

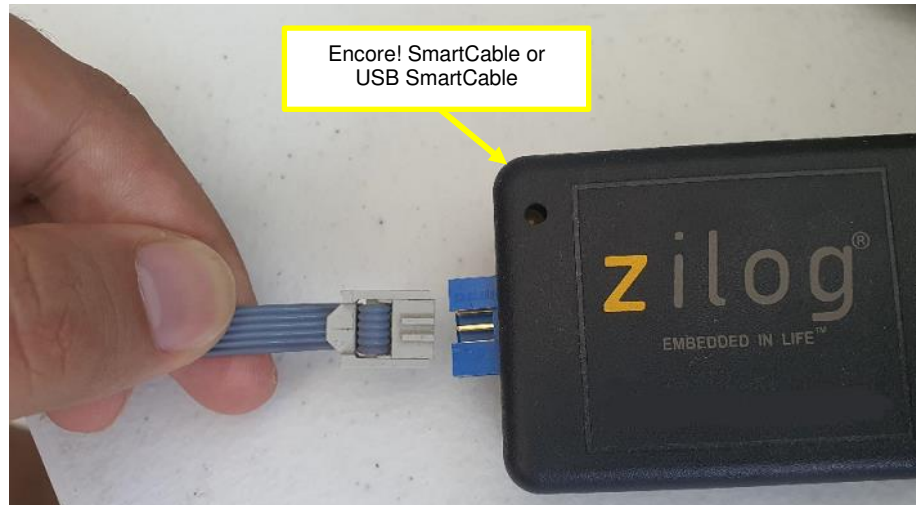

Figure 12. Connecting the 6-Circuit Ribbon Cable to the SmartCable

4. Connect the other end of the ribbon cable to NP Debug Connector J8 on the Development Board. Ensure that Pin 1 on the ribbon cable is aligned with Pin 1 on the target connector, as shown in the following figure.

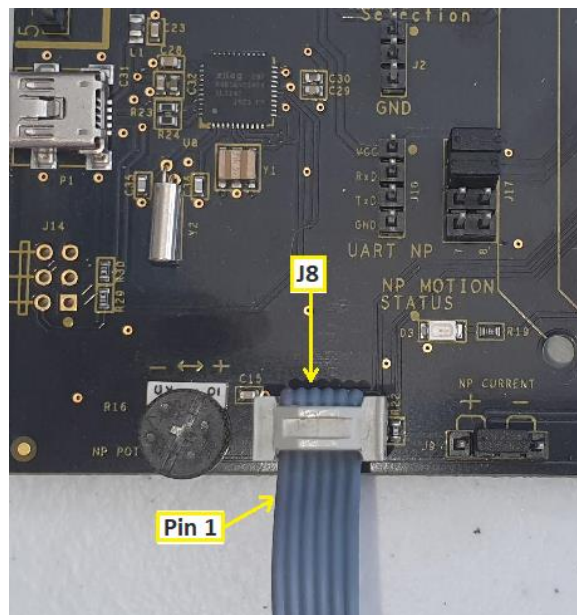
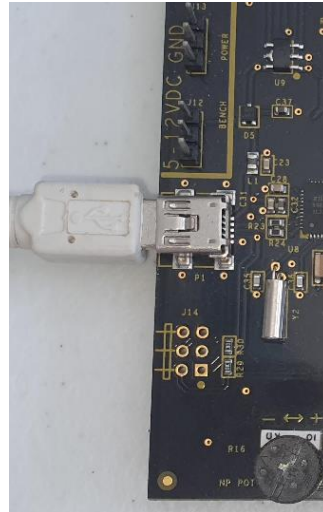

Figure 13. Connecting Ribbon Cable to NP Debug Connector J8

- With the USB A (male) to Mini-B cable, connect Port P1 on the ZMOTIONL400 Development Board to a USB port on the development PC to apply power and provide a serial interface for the Development Board. Refer to the following figure.



**Figure 14. Mini-USB Cable connection to ZMOTIONL400 Development Board**

- Open a serial terminal application like Teraterm, CoolTerm, or RealTerm and connect to the Zilog USB Serial Device at 57,600 bps, No Parity, 1 Stop bit. The USB serial port from the will be identified as USBSER000 (000 is the port instance) in the terminal application. If needed, open **Device Manager** and look under **Ports (COM & LPT)** to identify the COM port assigned to the Zilog USB Serial Device connected to the ZMOTIONL400 Development Board.
- Start ZDS II and open the NP Serial Command project (ZM\_NP\_Command.zdsproj). This can be done by starting ZDS II and opening the project by clicking **File** → **Open Project** from the menu or by navigating to the folder in Windows File Explorer and double-clicking the project file located in:

```
ZMOTIONL400ZCOG_x.x\Z8F3224 ZMOTION Library\Sample
Applications\ZMOTION_3224_NP_Command_Rx_x
```

The Rx\_x suffix indicates the project revision.

Four projects are provided. The projects share the same source code:

Project	Device Package	Bootloader
ZM_NP_Command_32.zdsproj	32-QFN	No
ZM_NP_Command_44.zdsproj	44-QFN	No
ZM_NP_Command_BL_32.zdsproj	32-QFN	Yes
ZM_NP_Command_BL_44.zdsproj	44-QFN	Yes

**Table 8. NP\_Command Project Options**

---

**Note:** When using the project with Bootloader, care must be taken not to set Breakpoints in the application code area when starting the application. Setting a Breakpoint modifies the Flash memory location to a Break instruction which will cause the Bootloader’s checksum test performed after reset to fail.

---



8. If using an Encore! SmartCable, set your Target VDD to “By External Source”
9. If the Debug icons are not displayed, as in the following figure, right-click in the empty grey area under the icons and select **Debug** and **Workbook Mode**.

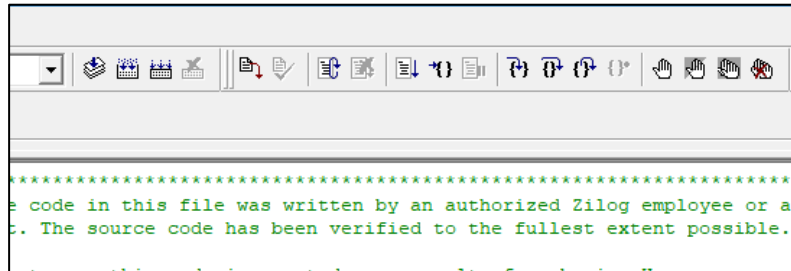

Figure 15. Debug Icons

10. Hover the mouse over each icon to display its function. Click the Rebuild All icon. ZDS II will build the project using the current versions of all source files and generate the necessary output files. If there were no errors detected during the build, a message similar to the one in the following figure will be displayed.

Space	Base	Top	Size	Used	Unused
EDATA	E:0100	E:0467	D00H ( 3328	368H 872	998H 2456)
RDATA	R:30	R:8C	COH ( 192	5DH 93	63H 99)
ROM	C:0000	C:3FED	8000H ( 32768	3FEEH 16366	4012H 16402)
OUTPUT CHECKSUM					
=====					
ZM_NP_Command_44_Pin.hex 87F2					
ZM_NP_Command_44_Pin.lod 87F2					
0 warning(s)					
0 error(s)					
Build succeeded.					

Figure 16. Build Succeeded Message

11. Click the **Go** icon. ZDS II will connect to the target MCU through the Encore! SmartCable or USB SmartCable, download the project to its Flash memory, reset the MCU, and start running the application. A message similar to the one shown in the following figure is displayed.

```

Connected to target ZMOTIONL400ZCOG
Starting debug session [project:ZM_NP_Command_44, configuration:ZM_NP_COMMAND]...
Cpu Z8F3224xN_2258 Rev AC,
Encore! SmartCable FW v1.0, Dfu Boot Loader v1.0
SN #2102180001
Loading file C:\From T440 Laptop\Projects2\ZMOTIONL400ZCOG\TPT\Z8F3224 Normal Power\ZMOTION_3224_NP_Command_R
Loading file C:\From T440 Laptop\Projects2\ZMOTIONL400ZCOG\TPT\Z8F3224 Normal Power\ZMOTION_3224_NP_Command_R
Checksum(NOT including pad bytes): 0x87F2

```

Figure 17. Message Displayed upon Connecting to Target MCU

12. The red LED (D3) should start flashing 1 second on, 1 second off while the application waits for the PIR sensor to stabilize.
13. If a serial terminal application is running and connected to the Zilog USB Serial Device, the messages similar to those shown in the following figure will be displayed.

```
Z8F3224 ZMOTION Serial Command
ZM_NP_Command
Version: 4.2

USE_DEBUG_STATE: 1

Motion Sensitivity Level: 8
Motion Delay Time (s): 1.5
Pet Immunity: OFF
Power On Walk Test Mode (s): Disabled
Hyper-Sense: Disabled
Pass Through: Disabled
Ambient Light Gating: Disabled
Motion LED On Time (s): 0.7
Transmit Motion Events: OFF
Temperature Compensation: OFF
Temperature Protection: OFF

Waiting for PIR Sensor Stability
*****
PIR Stable
```

Figure 18. Messages Displayed on Tera Term Serial Capture Program

14. Each time motion is detected, the terminal will display “**Motion Detected**”.
15. Other status messages are sent out the serial port. The amount of status information sent can be selected by setting USE\_DEBUG\_STATE to 0, 1, 2 or 3 in ProjectConfig.h.

# Documentation

Additional information can be found in the following documents. These are available free for download from the [Zilog website](#). They are also included with the ZDS II installation or the ZMOTIONL400ZCOG\_1.0 installation.

Description	Document ID	Installed Location
F3224 Series Product Specification	<a href="#">PS0381</a>	Documentation\Chip_Documentation
F6482 Series Product Specification	<a href="#">PS0294</a>	Documentation\Chip_Documentation
eZ8 CPU User Manual	<a href="#">UM0128</a>	Documentation\Chip_Documentation
Z8 Encore! Design for Debug	<a href="#">TN0036</a>	Documentation\Tools_Documentation
Encore! Smart Cable User Manual	<a href="#">UM0294</a>	Documentation\Tools_Documentation
USB SmartCable User Manual	<a href="#">UM0181</a>	Documentation\Tools_Documentation
Opto-Isolated USB SmartCable User Manual	<a href="#">UM0195</a>	Documentation\Tools_Documentation
Ethernet SmartCable User Manual	<a href="#">UM0207</a>	Documentation\Tools_Documentation
<b>Documents included in the ZMOTIONL400ZCOG_1.0 Installation</b>		
Description	Document ID	Installed Location
Z8F3224 ZMOTION Development Kit Quick Start Guide	<a href="#">QS0097</a>	Documentation
Z8F3224 ZMOTION Development Kit User Manual	<a href="#">UM0295</a>	Documentation\Tools_Documentation
ZMOTION Engine Library User Manual	<a href="#">UM0275</a>	Documentation
ZMOTION Product Brief	<a href="#">PB0258</a>	Documentation

**Table 9. Z8F3224 ZMOTION Development Kit Documentation**

# Appendix A

## Schematic Diagrams

The schematic diagram for the Z8F3224 ZMOTION Development Board is shown in the figures on the following pages.

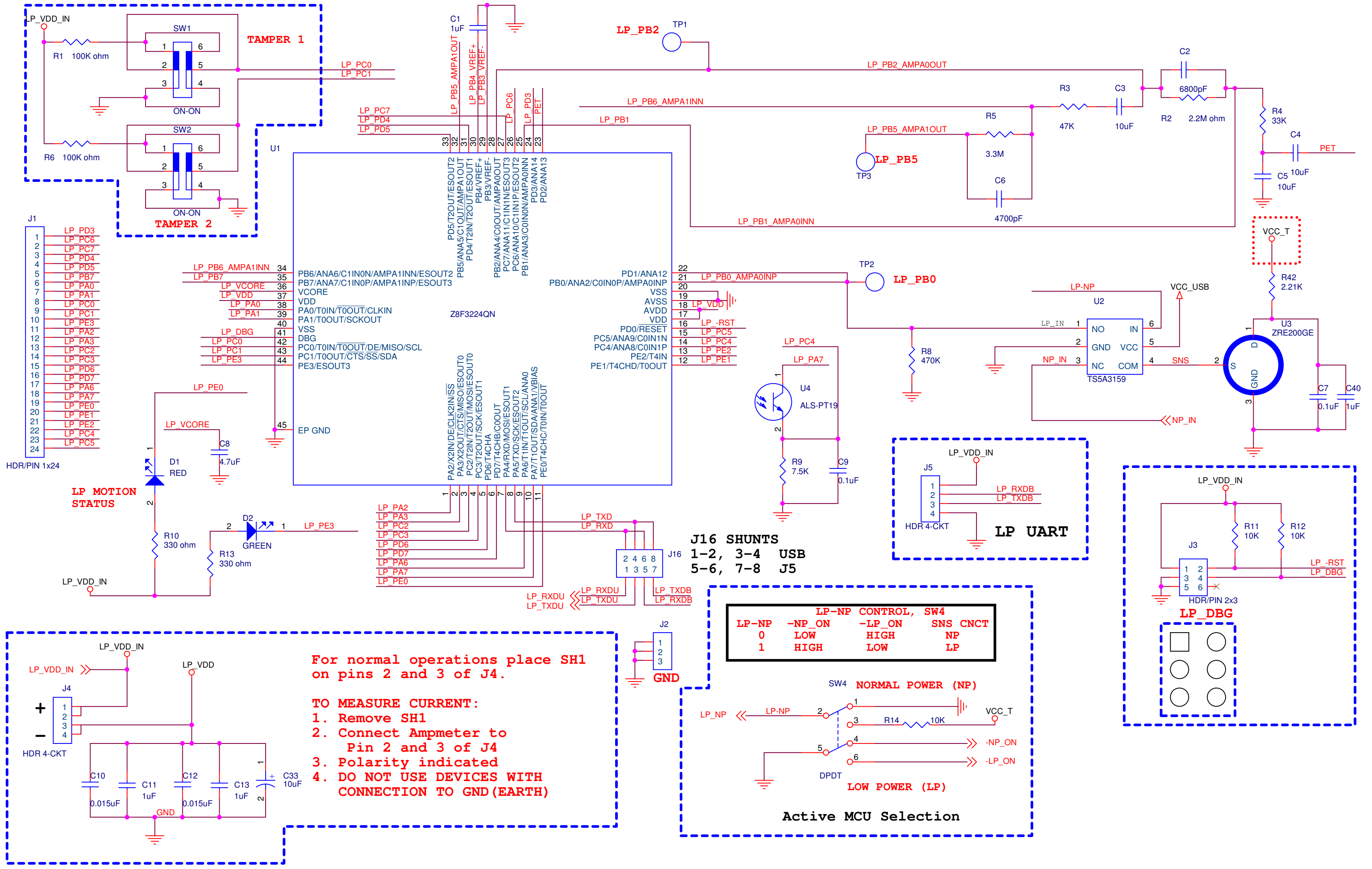

**For normal operations place SH1 on pins 2 and 3 of J4.**

- TO MEASURE CURRENT:**
1. Remove SH1
  2. Connect Ammeter to Pin 2 and 3 of J4
  3. Polarity indicated
  4. DO NOT USE DEVICES WITH CONNECTION TO GND (EARTH)

**LP-NP CONTROL, SW4**

LP-NP	-NP_ON	-LP_ON	SNS CNCT
0	LOW	HIGH	NP
1	HIGH	LOW	LP

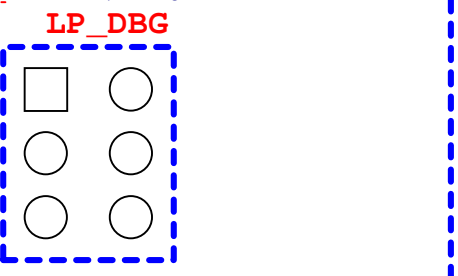
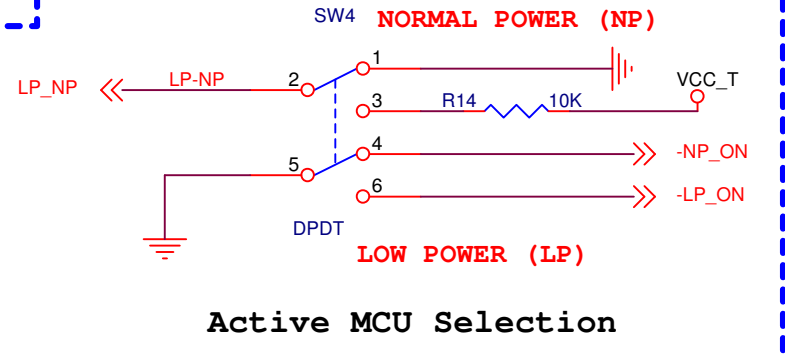

**J16 SHUNTS**  
 1-2, 3-4 USB  
 5-6, 7-8 J5

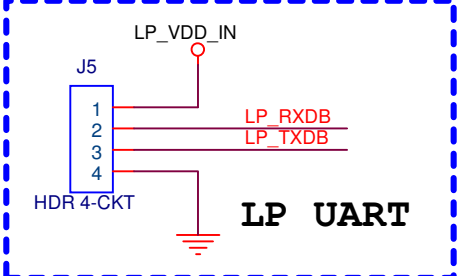

HDR/PIN 1x24

- J1**
- 1 LP\_PD3
  - 2 LP\_PC6
  - 3 LP\_PC7
  - 4 LP\_PD4
  - 5 LP\_PD5
  - 6 LP\_PB7
  - 7 LP\_PA0
  - 8 LP\_PA1
  - 9 LP\_PC0
  - 10 LP\_PC1
  - 11 LP\_PC3
  - 12 LP\_PA2
  - 13 LP\_PC2
  - 14 LP\_PC3
  - 15 LP\_PD6
  - 16 LP\_PD7
  - 17 LP\_PA6
  - 18 LP\_PA7
  - 19 LP\_PE0
  - 20 LP\_PE1
  - 21 LP\_PE2
  - 22 LP\_PC4
  - 23 LP\_PC5
  - 24

- LP PB6 AMPA1INN** 34
- LP PB7** 35
- LP VCORE** 36
- LP VDD** 37
- LP PA0** 38
- LP PA1** 39
- LP DBG** 40
- LP PC0** 41
- LP PC1** 42
- LP PE3** 43
- LP PE3** 44

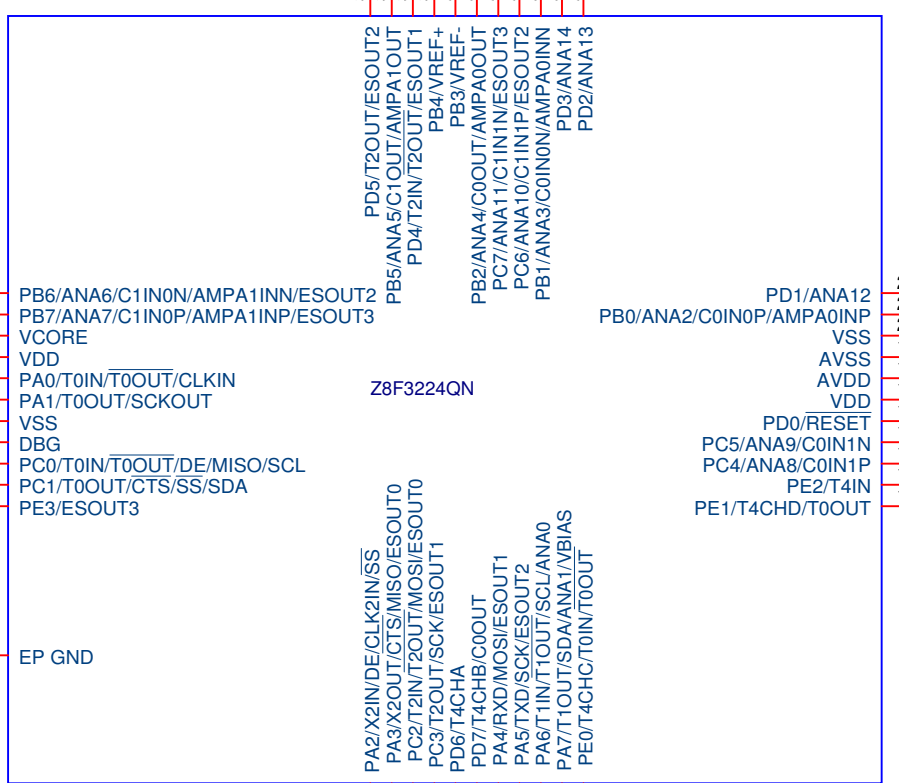

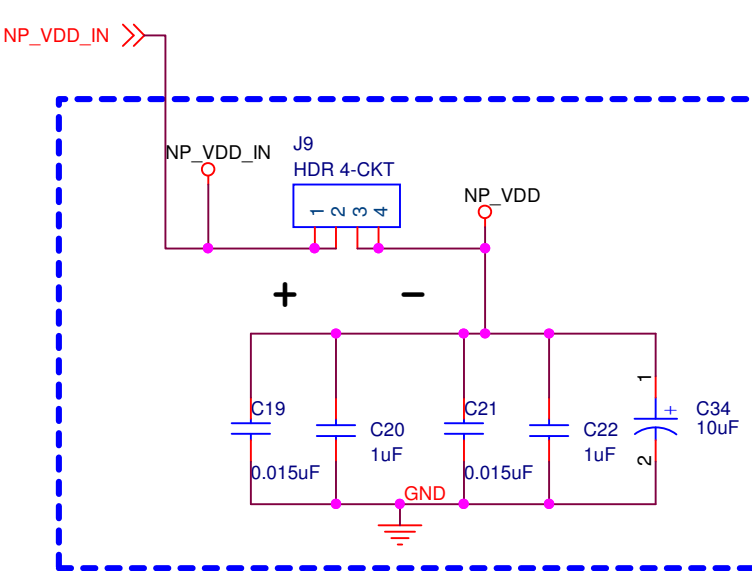
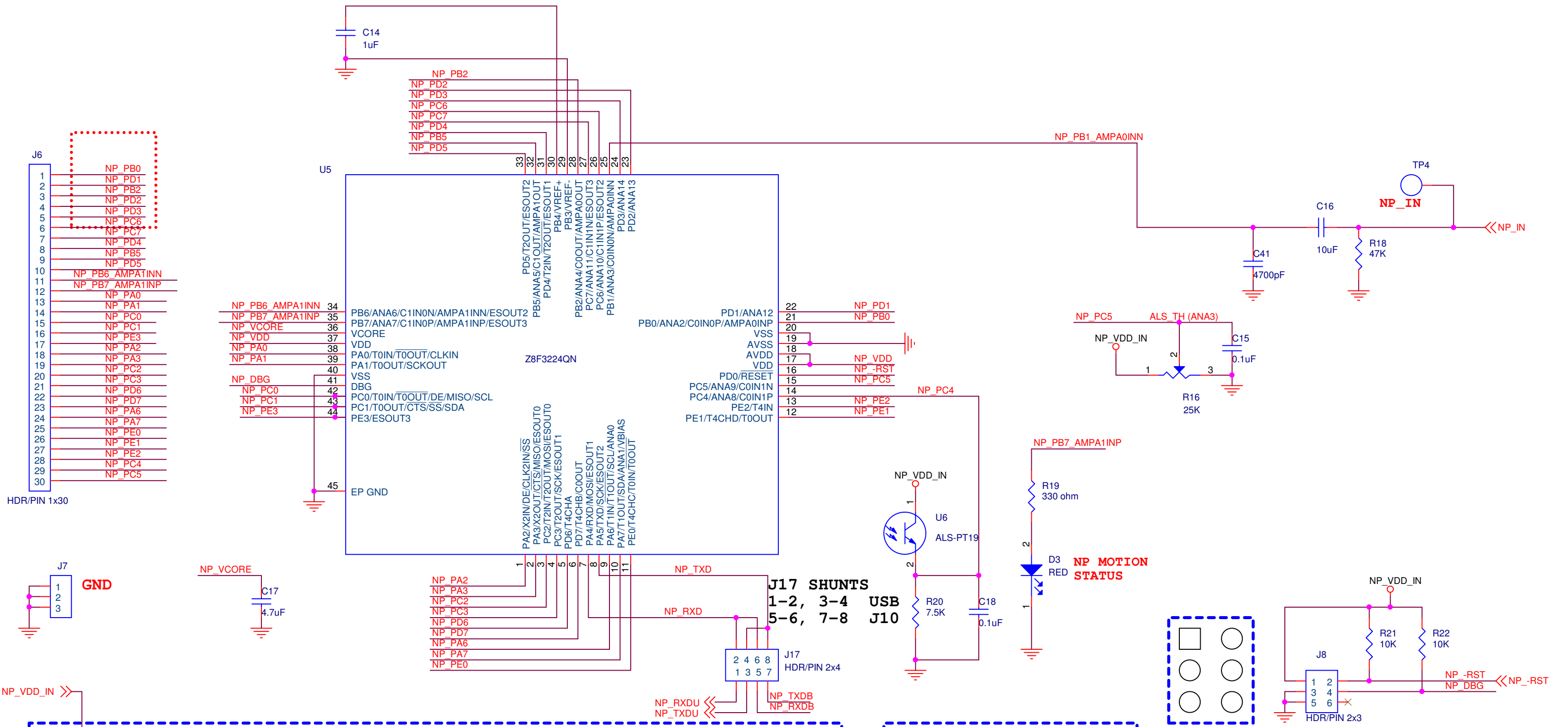

**For normal operation place SH2 on pins 2 and 3 of J9**

**TO MEASURE CURRENT:**

1. Remove SH2
2. Connect Ammeter to Pin 1 and 4 of J9
3. Polarity indicated
4. DO NOT USE DEVICES WITH CONNECTION TO GND (EARTH)

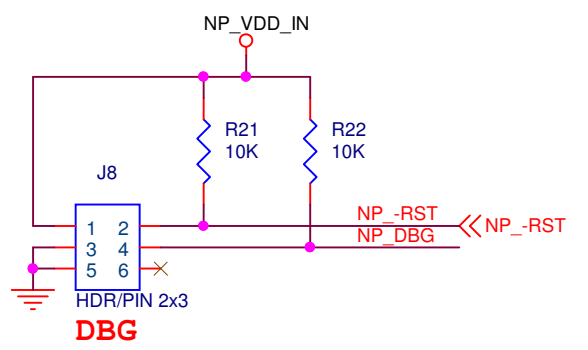
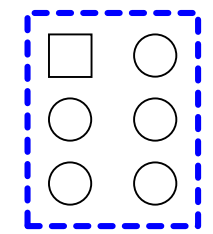
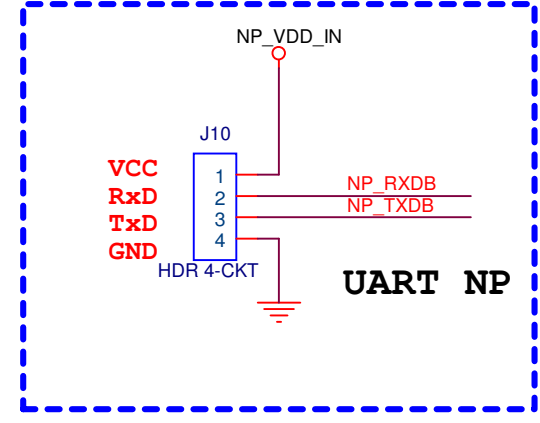



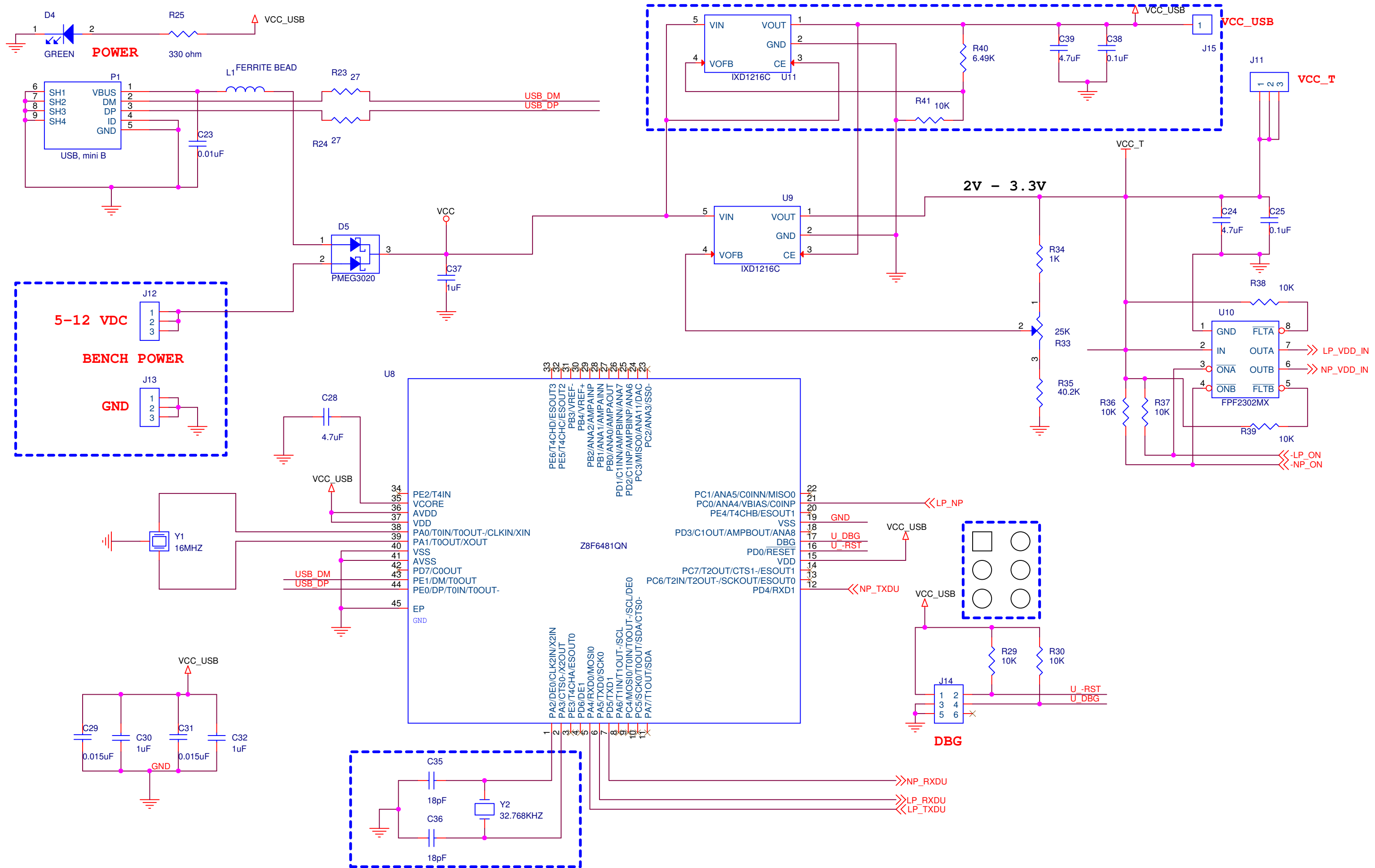

# Appendix B

## IDE-Zilog Developer Studio II

Observe the following steps to download and install the ZDS II software package.

---

**Note:** If you have already installed ZDS II – Z8 Encore! Version 5.6.0 or later and have downloaded the sample applications and documentation by following the procedure on the paper insert in your kit (FL0198), you're ready for [Appendix D. Installing the Encore! SmartCable Driver](#) or [Appendix C. Installing the USB SmartCable Driver](#)

---

1. Prior to connecting the Z8F3224 ZMOTION Development Board to your development PC, download ZDS II for Z8 Encore! v5.6.0 (or later) from the [Zilog website](#).
  - Select the most recent version of ZDS II – Z8 Encore!
2. When your download is complete, double-click the installation file named `ZDS2_Z8Encore!<version>.exe`, and follow the on-screen instructions.

## Supported Operating Systems

ZDS-II is supported for the following operating systems:

- Microsoft Windows 10 (32-bit/64-bit)
- Microsoft Windows 8 (32-bit/64-bit)
- Microsoft Windows 7 (32-bit/64-bit)

# Appendix C

## Installing the USB SmartCable Driver

1. Connect the USB Smart Cable to the host PC. A Windows message appears, stating *Driver Software Installation*.
2. Windows automatically searches for the driver. This process can take a while to complete. However, because there is no option to terminate this process immediately, Zilog advises waiting for the search to complete. If the driver was previously installed on your system, Windows automatically installs the USB Smart Cable driver. If this is the case, skip ahead to Step 8. If the driver was not found, close the Search dialog and proceed to Step 3.
3. Go to the Windows Start menu and, in the Search programs and files field, enter Device Manager. The Windows Device Manager should appear in the list of returned items in your search; click this item to launch the Device Manager.
4. A selection label as **Other devices** should appear in the list of hardware devices currently running in the Device Manager. Click the arrow to the left of Other Devices to display these additional devices.
5. Right-click USB Smart Cable to select Update Driver Software, which will display the Update Driver Software - USB Smart Cable dialog.
6. Select the Browse my computer for driver software option in this dialog, then browse to one of the following driver directories:
  - 32-bit systems:  
`<ZDS II Installation Directory>\device drivers\USB\x32`
  - 64-bit systems:  
`<ZDS II Installation Directory>\device drivers\USB\x64`
7. Click Next to install the driver. In 32-bit systems, the Windows Security dialog will appear: click Install this driver software anyway.
8. Click Close after the Wizard finishes the installation.

# Appendix D

## Installing the Encore! SmartCable Driver

**Note:** You might have done the driver installation on ZDSII – Z8 Encore! 5.6.0 installation, when the check box is selected on below screen shot and clicked **Finish**. If so, you don't need to do the following below steps, but there is no harm proceeding

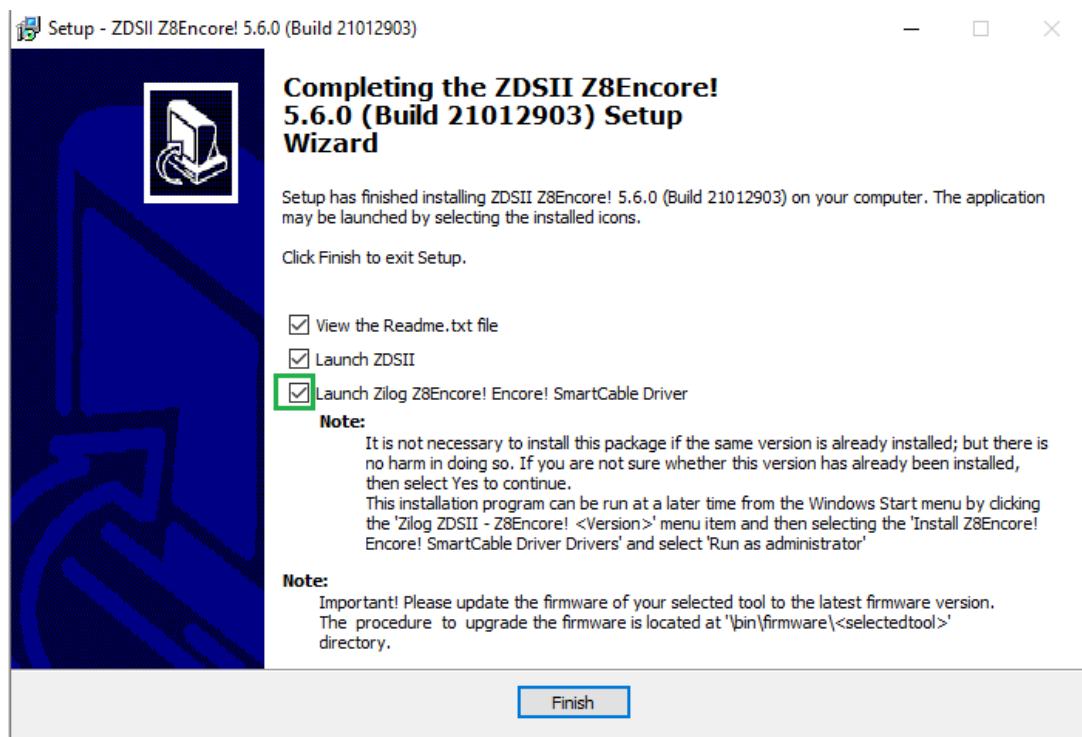

1. Navigate to Start >All Programs >ZiLOG ZDSII – Z8 Encore! 5.6.0
2. Right click on Install Encore! SmartCable Driver and select Run as administrator
3. Click on **Yes** button on the User Account Control prompt that appears
4. Click on **Yes** button on the Encore! SmartCable Driver Installation prompt to install the driver software
5. Select **Next** button that appears
6. Select the **Finish** button

# Revision History

Each instance in this document's revision history reflects a change from its previous edition. For more details, refer to the corresponding page(s) or appropriate links furnished in the table below.

---

<b>Date</b>	<b>Revision Level</b>	<b>Description</b>	<b>Page</b>
March 2021	01	Original issue.	All

---

# Customer Support

To share comments, get your technical questions answered, or report issues you may be experiencing with our products, please visit Zilog's Technical Support page at [support.zilog.com](http://support.zilog.com).

To learn more about this product, find additional documentation, or to discover other facets about Zilog product offerings, please visit the [Zilog Knowledge Base](#).

This publication is subject to replacement by a later edition. To determine whether a later edition exists, please visit the Zilog website at [www.zilog.com](http://www.zilog.com).