

RECOMMENDED P.C.B. LAYOUT (Both sides are sample)
Tolerance: ±0.05, Thickness=0.60mm

NOTE:

1. MATERIAL SPECIFICATION:
 - 1-1. HOUSING: HIGH TEMPERATURE THERMAL PLASTIC, UL94 V-0.
 - 1-2. TERMINAL: COPPER ALLOY
 - 1-3. MID PLATE: STAINLESS STEEL
 - 1-4. GND: STAINLESS STEEL
 - 1-5. SHELL: STAINLESS STEEL
 - 1-6. GLUE WATER: EPOXY
2. PLATING SPECIFICATION:
 - 2-1. CONTACTS:
 - NICKEL PLATING UNDER PLATED OVER ALL.
 - AU PLATED ON THE CONTACT AREA.
 - (GOLD PLATING THICKNESS FOLLOW THE P/N)
 - GOLD FLASH ON THE SOLDER AREA
 - 2-2. GND PLATE AND SHELL
 - NICKEL PLATING. UNDER PLATED OVER ALL.
 - 2-3. MIDDLE PLATE:
 - CLEAR ONLY
3. ELECTRICAL :
 - 3-1. CONTACT CURRENT RATING :
 - 5A (VBUS PIN 1.5A/PIN),
 - 5A (GND PIN 1.25A/PIN MAX), 0.25A/PIN (OTHER PIN).
 - 3-2. INSULATION RESISTANCE : 100 MEGAOHMS MIN. AT 250VDC.
 - 3-3. DIELECTRIC WITHSTANDING VOLTAGE : 100VAC MIN.
 - 3-4. LOW LEVEL CONTACT RESISTANCE :
 - INITIAL 40mΩ MAX.
 - AFTER 50mΩ MAX.
4. MECHANICAL CHARACTERISTICS :
 - 4-1. MATING FORCE: 5~20N.
 - 4-2. UNMATING FORCE: 8~20N (INITIAL), 6~20N (AFTER 10000 CYCLES);
 - 4-3. DURABILITY : 10,000 MATING CYCLES.
 - 4-4. OPERATING TEMPERATURE : -40°C TO +80°C

PART NUMBER DESCRIPTION:
10164986-000 X X LF

- PACKAGING
 1. TRAY
- CONTACT PLATING
 1. GOLD FLASH
 2. 30u" Au
 3. 15u" Au

mat'l. code		surface	tolerance	projection	product family
		ISO 1302	ISO 406	ISO 1101	HPL 511
ltr	ecn no	dr	date	tolerances unless otherwise specified	title
A	-	YY	2022/03/14	angles	USB TYPE C FEMALE
				linear	R/A HYBRID SINK TYPE IP67
				0°±2'	dwg no
				dr Y-Y Bao	sheet 1 of 2
				engr Y-Y Bao	size
				chr LQ Lei	10164986
				appd Tim Yao	A3
					type Product Customer Drawing
sheet	revision				
index	sheet				

RECOMMENDED SEALING METHOD

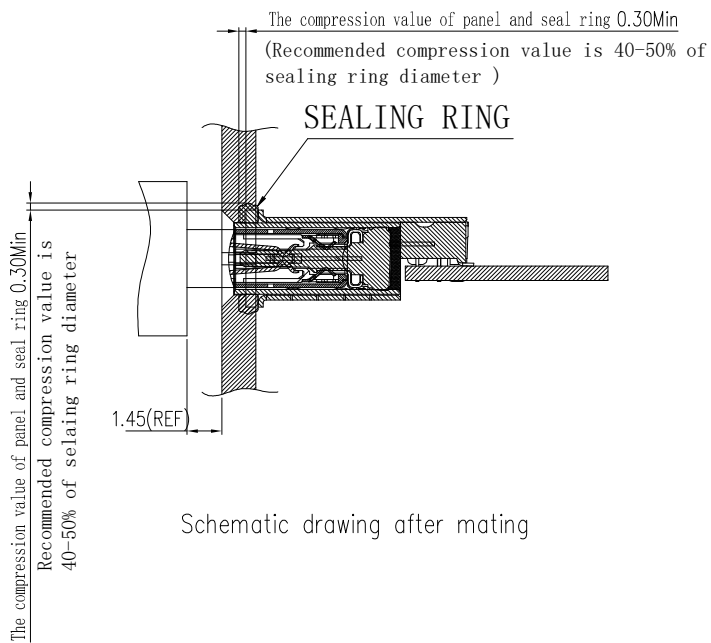
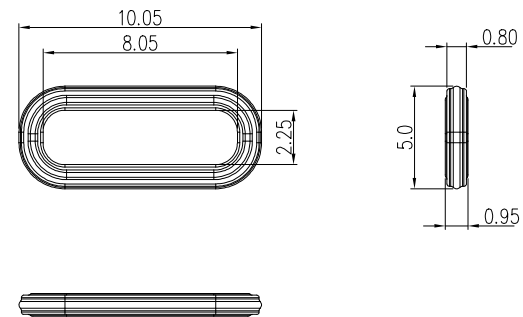
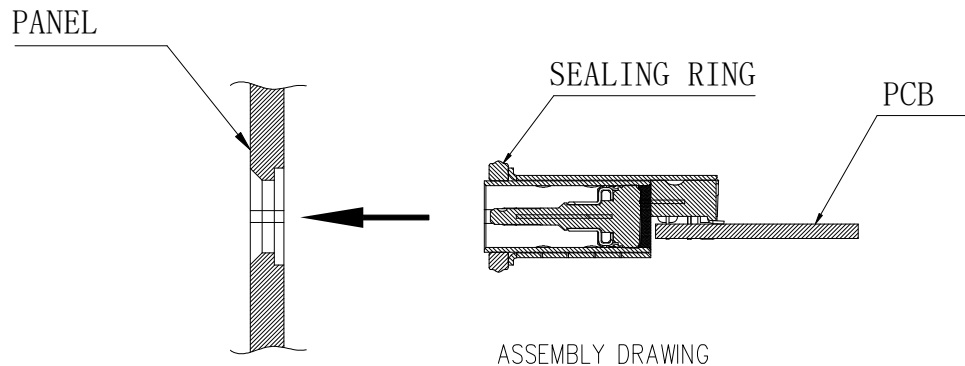

mat'l. code		surface	tolerance	projection	product family
		ISO 1302 ✓	ISO 406 ISO 1101		HPL 511
ltr	ecn no	dr	date	tolerances unless otherwise specified	title
A				linear	USB TYPE C FEMALE R/A HYBRID SINK TYPE IP67
				mm	
				0°±2'	scale 1:1
		dr	Y-Y Bao	2022/03/14	dwg no
		engr	Y-Y Bao	2022/03/14	sheet 1 of 2
		chr	LQ Lei	2022/03/14	size
		appd	Tim Yao	2022/03/14	10164986
					type Product Customer Drawing
sheet index	revision sheet				