

Description

The ICS650-22 is a low-cost, low-jitter, high-performance clock synthesizer for personal video recorders (PVR) and set-top box (STB) applications. Using analog Phase-Locked Loop (PLL) techniques, the device accepts a 27 MHz crystal input to produce multiple clocks for personal video recorder applications.

Features

- Packaged in 20-pin narrow SSOP (QSOP)
- Pb (lead) free package, RoHS compliant
- 27 MHz fundamental crystal or clock input
- Zero ppm synthesis error in all clocks
- Low skew 33.33 MHz clock outputs
- Output enable controls all outputs
- Full CMOS output swing with 25 mA output drive capability at TTL levels
- Advanced, low-power, sub-micron CMOS process
- 3.3 V \pm 10% operating voltage

Block Diagram

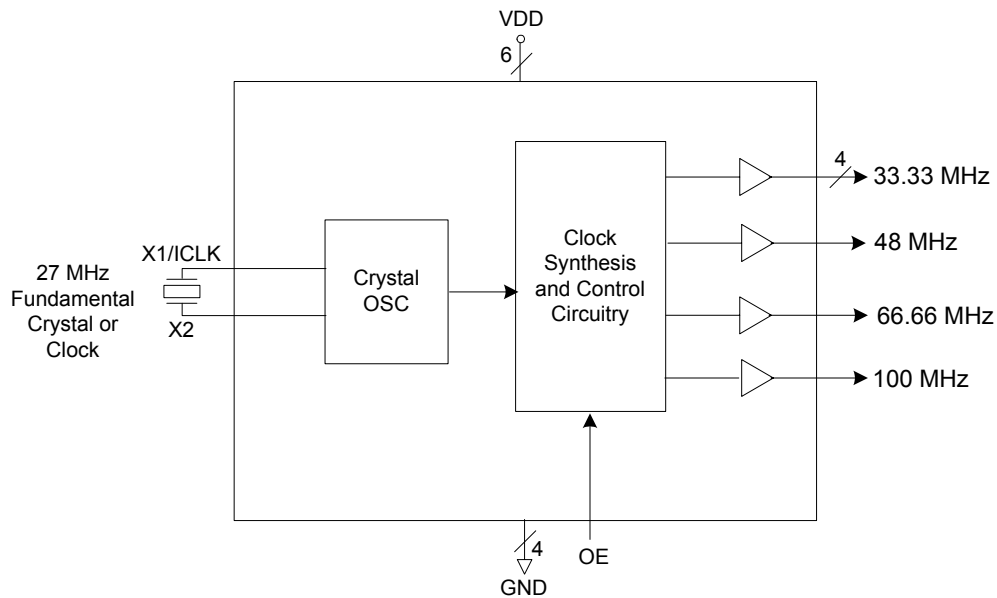

Pin Assignment

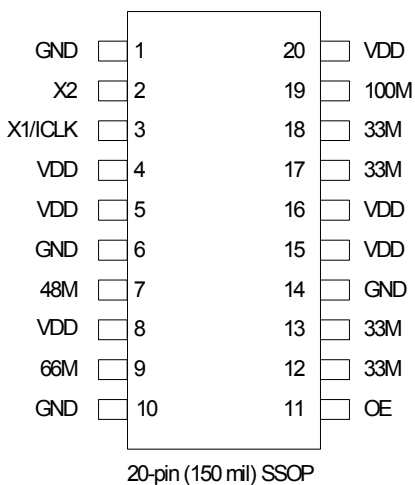

Pin Descriptions

Pin Number	Pin Name	Pin Type	Pin Description
1	GND	Power	Connect to ground.
2	X2	Input	Connect to a crystal input or leave open for ICLK.
3	X1/ICLK	Input	Connect to a crystal or reference clock input.
4, 5	VDD	Power	Connect to +3.3 V.
6	GND	Power	Connect to ground.
7	48M	Output	48 MHz clock output.
8	VDD	Power	Connect to +3.3 V.
9	66M	Output	66 MHz clock output.
10	GND	Power	Connect to ground.
11	OE	Input	Output enable active high. Internal pull-up resistor.
12, 13	33M	Output	33.33 MHz clock output.
14	GND	Power	Connect to ground.
15, 16	VDD	Power	Connect to +3.3 V.
17, 18	33M	Output	33.33 MHz clock output.
19	100M	Output	100 MHz clock output.
20	VDD	Power	Connect to +3.3 V.

Absolute Maximum Ratings

Stresses above the ratings listed below can cause permanent damage to the ICS650-22. These ratings, which are standard values for IDT commercially rated parts, are stress ratings only. Functional operation of the device at these or any other conditions above those indicated in the operational sections of the specifications is not implied. Exposure to absolute maximum rating conditions for extended periods can affect product reliability. Electrical parameters are guaranteed only over the recommended operating temperature range.

Item	Rating
Supply Voltage, VDD	7 V
All Inputs and Outputs	-0.5 V to VDD+0.5 V
Ambient Operating Temperature	-40 to +85° C
Storage Temperature	-65 to +150° C
Junction Temperature	125° C
Soldering Temperature	260° C

Recommended Operation Conditions

Parameter	Min.	Typ.	Max.	Units
Ambient Operating Temperature	0	-	+70	°C
Power Supply Voltage (measured in respect to GND)	+3.0	+3.3	+3.6	V

DC Electrical Characteristics

Unless stated otherwise, VDD = 3.3V ±10%, Ambient Temperature 0 to +70° C

Parameter	Symbol	Conditions	Min.	Typ.	Max.	Units
Operating Voltage	VDD		3.0	3.3	3.6	V
Input High Voltage	V _{IH}		VDD/2+1	VDD/2		V
Input Low Voltage	V _{IL}			VDD/2	VDD/2-1	V
Output High Voltage	V _{OH}	I _{OH} = -25 mA	2.4			V
Output Low Voltage	V _{OL}	I _{OL} = +25 mA			0.5	V
Output High Voltage	V _{OL}	I _{OH} = -8 mA	VDD-0.4			V
Operating Supply Current	I _{DD}	No Load, OE=1		29		mA
		No Load, OE=0		13		mA
Short Circuit Current	I _{OS}	Each output		±70		mA
Internal Pull-up Resistor	R _{PU}	Input select		390		kΩ

AC Electrical Characteristics

Unless stated otherwise, VDD = 3.3V ±10%, Ambient Temperature 0 to +70° C

Parameter	Symbol	Conditions	Min.	Typ.	Max.	Units
Input Frequency				27		MHz
Output Rise Time	t _{OR}	0.8 to 2.0 V (note 1)		500		ps
Output Fall Time	t _{OF}	2.0 to 0.8 V (note 1)		500		ps
Output Clock Duty Cycle		At VDD/2 (note 1)	45	50	55	%
Frequency Error		All clocks			0	ppm
Absolute Jitter, short term		33M, 100M clocks (note 1)		±100		ps
Absolute Jitter, short term		48M clock (note 1)		±160		ps
Absolute Jitter, short term		66M clock (note 1)		±140		ps
Output-to-output Skew, 33M only		Rising edge at VDD/2 (note 1)		0	150	ps

Note 1: Measured with a 15 pF load.

Thermal Characteristics

Parameter	Symbol	Conditions	Min.	Typ.	Max.	Units
Thermal Resistance Junction to Ambient	θ _{JA}	Still air		135		°C/W
	θ _{JA}	1 m/s air flow		93		°C/W
	θ _{JA}	3 m/s air flow		78		°C/W
Thermal Resistance Junction to Case	θ _{JC}			60		°C/W

Package Outline and Package Dimensions (20-pin SSOP, 150 Mil. Body)

Package dimensions are kept current with JEDEC Publication No. 95

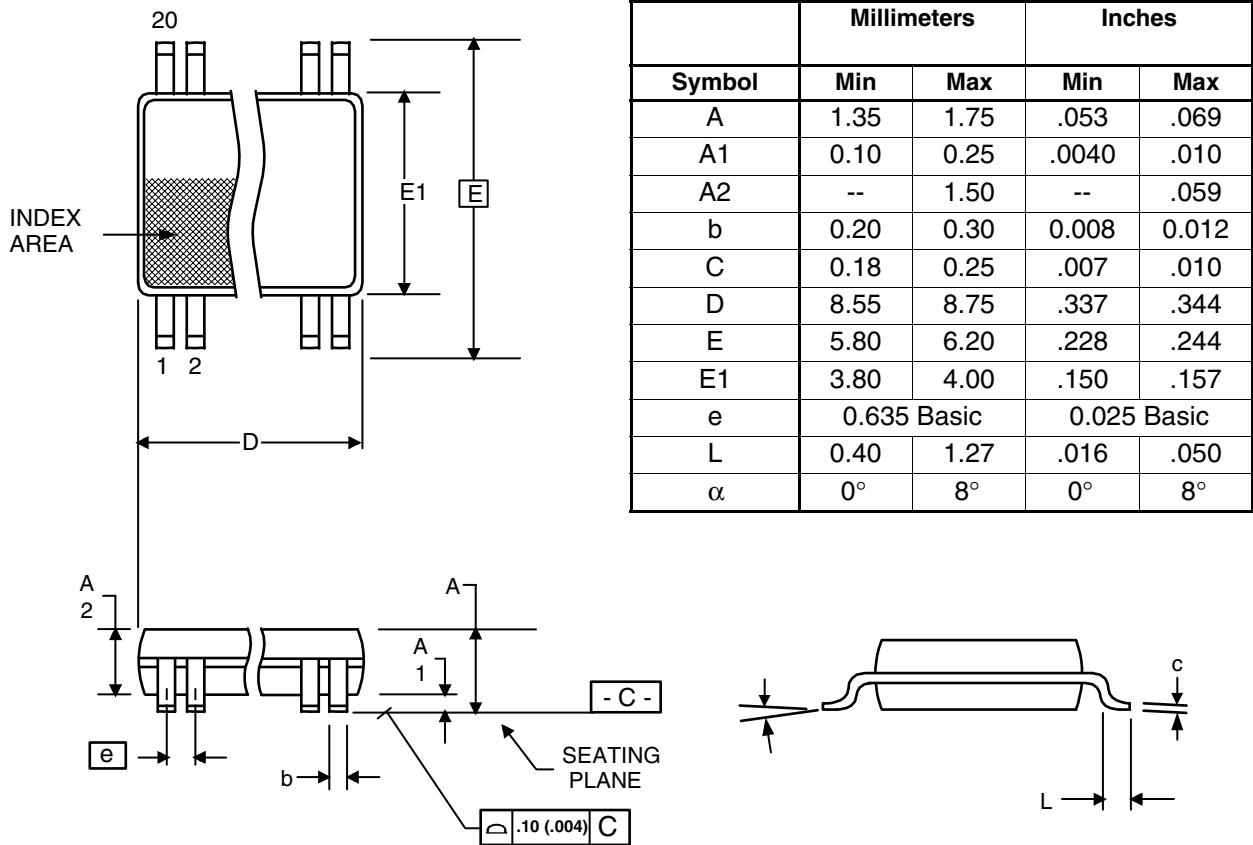

Ordering Information

Part / Order Number	Marking	Shipping Packaging	Package	Temperature
650R-22LF	650R-22L	Tubes	20-pin SSOP	0 to +70° C
650R-22LFT	650R-22L	Tape and Reel	20-pin SSOP	0 to +70° C

“LF” denotes Pb (lead) free package.

While the information presented herein has been checked for both accuracy and reliability, Integrated Device Technology (IDT) assumes no responsibility for either its use or for the infringement of any patents or other rights of third parties, which would result from its use. No other circuits, patents, or licenses are implied. This product is intended for use in normal commercial applications. Any other applications such as those requiring extended temperature range, high reliability, or other extraordinary environmental requirements are not recommended without additional processing by IDT. IDT reserves the right to change any circuitry or specifications without notice. IDT does not authorize or warrant any IDT product for use in life support devices or critical medical instruments.

IMPORTANT NOTICE AND DISCLAIMER

RENESAS ELECTRONICS CORPORATION AND ITS SUBSIDIARIES (“RENESAS”) PROVIDES TECHNICAL SPECIFICATIONS AND RELIABILITY DATA (INCLUDING DATASHEETS), DESIGN RESOURCES (INCLUDING REFERENCE DESIGNS), APPLICATION OR OTHER DESIGN ADVICE, WEB TOOLS, SAFETY INFORMATION, AND OTHER RESOURCES “AS IS” AND WITH ALL FAULTS, AND DISCLAIMS ALL WARRANTIES, EXPRESS OR IMPLIED, INCLUDING, WITHOUT LIMITATION, ANY IMPLIED WARRANTIES OF MERCHANTABILITY, FITNESS FOR A PARTICULAR PURPOSE, OR NON-INFRINGEMENT OF THIRD PARTY INTELLECTUAL PROPERTY RIGHTS.

These resources are intended for developers skilled in the art designing with Renesas products. You are solely responsible for (1) selecting the appropriate products for your application, (2) designing, validating, and testing your application, and (3) ensuring your application meets applicable standards, and any other safety, security, or other requirements. These resources are subject to change without notice. Renesas grants you permission to use these resources only for development of an application that uses Renesas products. Other reproduction or use of these resources is strictly prohibited. No license is granted to any other Renesas intellectual property or to any third party intellectual property. Renesas disclaims responsibility for, and you will fully indemnify Renesas and its representatives against, any claims, damages, costs, losses, or liabilities arising out of your use of these resources. Renesas' products are provided only subject to Renesas' Terms and Conditions of Sale or other applicable terms agreed to in writing. No use of any Renesas resources expands or otherwise alters any applicable warranties or warranty disclaimers for these products.

(Disclaimer Rev.1.0 Mar 2020)

Corporate Headquarters

TOYOSU FORESIA, 3-2-24 Toyosu,
Koto-ku, Tokyo 135-0061, Japan
www.renesas.com

Contact Information

For further information on a product, technology, the most up-to-date version of a document, or your nearest sales office, please visit:
www.renesas.com/contact/

Trademarks

Renesas and the Renesas logo are trademarks of Renesas Electronics Corporation. All trademarks and registered trademarks are the property of their respective owners.