

Photologic Hermetic Sensors

OPL800, OPL800-OC, OPL801, OPL801-OC, OPL810, OPL811, OPL811-OC, OPL813-OC, OPL820, OPL820-OC



Obsolete (OPL810-OC, OPL812-OC, OPL821-OC)



Features:

- Four output options available
- High noise immunity
- Direct TTL/LSTTL interface
- TO-18 hermetically sealed package
- Sensors mechanically and spectrally matched to other Optek devices (see device descriptions detailed below)

Description:

All **OPL800**, **OPL801** and **OPL820** sensors consist of a photodiode, a linear amplifier and a Schmitt trigger on a single silicon chip (monolithic chip for **OPL820**). **OPL810**, **OPL811** and **OPL813** sensors also have a voltage regulator added to their photologic chips. Each device's photologic chip is mounted onto a standard TO-18 header and hermetically sealed in a lensed metal can.

All devices in the series feature TTL/LSTTL compatible logic level output, which can drive up to 8 TTL loads (**OPL800**, **OPL801**) or up to 10 TTL loads (**OPL810**, **OPL811**, **OPL813** and **OPL820**) without additional circuitry. On all these devices, the Schmitt trigger's hysteresis characteristics provide high immunity to noise on input and V_{CC} .

OPL800 series devices feature medium-speed data rates to 250 kbaud, with typical rise and fall times of 25 nanoseconds.

OPL800 and OPL801 devices are mechanically and spectrally matched to OP130 and OP231 series LEDs. OPL810, OPL811, OPL813 devices are mechanically and spectrally matched to OP130 and OP230 series devices. OPL820 devices are mechanically and spectrally matched to OP130 and OP231 series LEDs.

Applications:

- Non-contact reflective object sensor
- Assembly line automation
- Machine automation
- Machine safety
- End of travel sensor
- Door sensor

Pin #	OPL80_ or OPL81_	OPL82_
1	Ground	Ground
2	V_{CC}	Output
3	Output	V_{CC}

Mounted to TO-18 Base

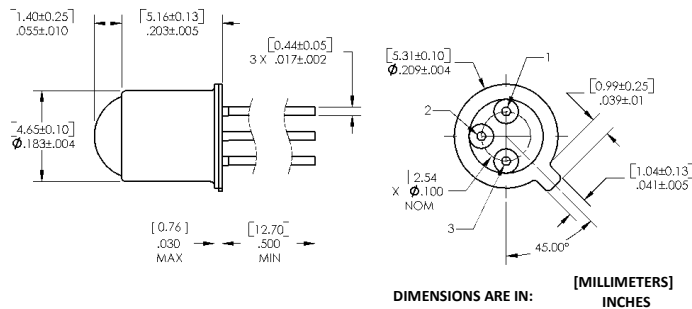

RoHS

General Note

TT Electronics reserves the right to make changes in product specification without notice or liability. All information is subject to TT Electronics' own data and is considered accurate at time of going to print.

TT Electronics | OPTEK Technology
2900 E. Plano Pkwy, Plano, TX 75074 | Ph: +1 972 323 2200
www.ttelectronics.com | sensors@ttelectronics.com

Photologic Hermetic Sensors

OPL800, OPL800-OC, OPL801, OPL801-OC, OPL810,
OPL811, OPL811-OC, OPL813-OC, OPL820, OPL820-OC



Obsolete (OPL810-OC, OPL812-OC, OPL821-OC)

Ordering Information					
Part Number	Photologic®	Input Power E_e ($\mu\text{W}/\text{cm}^2$) Min / Max	V_{cc} (V) Min / Max	I_{OH} / I_{OL}	Lead Length
OPL800	Totem-Pole	50 / 600	4.5 / 16.0	0.10 / 12.8	0.50"
OPL800-OC	Open-Collector				
OPL801	Inv-Totem-Pole				
OPL801-OC	Inv-Open-Collector				
OPL810	Totem-Pole	5 / 100	4.5 / 16.0	0.10 / 16.0	
OPL810-OC Obsolete	Open-Collector				
OPL811	Inv-Totem-Pole				
OPL811-OC	Inv-Open-Collector				
OPL812-OC Obsolete	Open-Collector	2 / 35			
OPL813-OC	Inv-Open-Collector				
OPL820	10K Pull-Up				
OPL820-OC	Open Collector				
OPL821-OC Obsolete	Inv. Open Collector				

OPL800, OPL800-OC, OPL801, OPL801-OC, OPL810, OPL811, OPL811-OC, OPL813-OC, OPL820-OC

OPL800/810 Buffered Totem-Pole

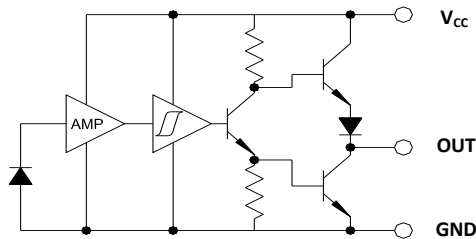

OPL800-OC/820-OC Open-Collector

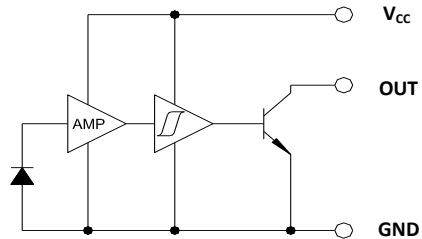

OPL801/811 Inverted Totem-Pole

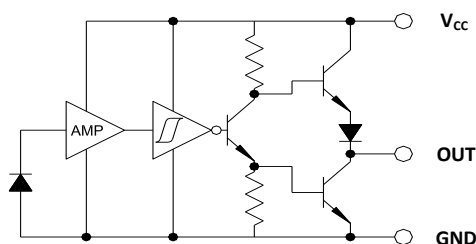

OPL801-OC/811-OC/813-OC Inverted Open-Collector

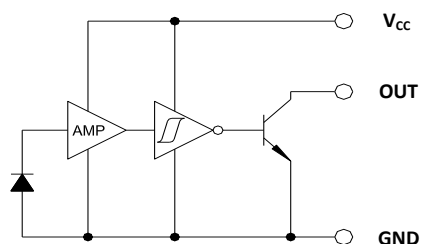

General Note

TT Electronics reserves the right to make changes in product specification without notice or liability. All information is subject to TT Electronics' own data and is considered accurate at time of going to print.

TT Electronics | OPTEK Technology
2900 E. Plano Pkwy, Plano, TX 75074 | Ph: +1 972 323 2200
www.ttelectronics.com | sensors@ttelectronics.com

Photologic Hermetic Sensors

OPL800, OPL800-OC, OPL801, OPL801-OC, OPL810,
OPL811, OPL811-OC, OPL813-OC, OPL820, OPL820-OC



Obsolete (OPL810-OC, OPL812-OC, OPL821-OC)

OPL820

OPL820 10K Pull-Up

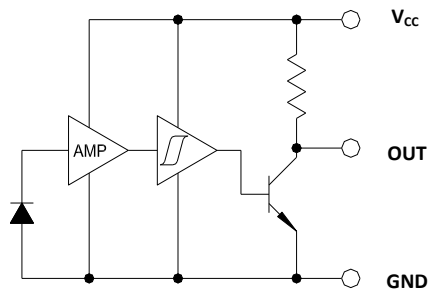

General Note

TT Electronics reserves the right to make changes in product specification without notice or liability. All information is subject to TT Electronics' own data and is considered accurate at time of going to print.

TT Electronics | OPTEK Technology
2900 E. Plano Pkwy, Plano, TX 75074 | Ph: +1 972 323 2200
www.ttelectronics.com | sensors@ttelectronics.com

Photologic Hermetic Sensors

OPL800, OPL800-OC, OPL801, OPL801-OC, OPL810,
OPL811, OPL811-OC, OPL813-OC, OPL820, OPL820-OC



Obsolete (OPL810-OC, OPL812-OC, OPL821-OC)

Electrical Specifications

Absolute Maximum Ratings ($T_A = 25^\circ\text{C}$ unless otherwise noted)

OPL800/801/810/811 and OPL800-OC Series

Input Diode	
Operating Temperature Range OPL800, OPL801 OPL810, OPL811 OPL820	-55° C to +110° C -55° C to +105° C -40° C to +100° C
Storage Temperature Range OPL800, OPL801 OPL810, OPL811 OPL820	-65° C to +150° C -65° C to +125° C -55° C to +125° C
Lead Soldering Temperature [1/16 inch (1.6 mm) from the case for 5 sec. with soldering iron]	260° C ⁽¹⁾
Input Infrared LED	
Supply Voltage, V_{CC} (not to exceed 3 seconds) OPL800, OPL801 OPL810, OPL811, OPL820	10 V 18 V
Sourcing Current OPL810, OPL811	10 mA
Output Voltage (high state) OPL800, OPL801, OPL810, OPL811 OPL820	35 V 30 V
Output Current Sink (low state) OPL810, OPL811 OPL820	50 mA 16 mA
Irradiance OPL800, OPL801 OPL810, OPL811, OPL811-OC OPL813-OC	3 mW/cm ² 2 mW/cm ² 1 mW/cm ²

General Note

TT Electronics reserves the right to make changes in product specification without notice or liability. All information is subject to TT Electronics' own data and is considered accurate at time of going to print.

TT Electronics | OPTEK Technology
2900 E. Plano Pkwy, Plano, TX 75074 | Ph: +1 972 323 2200
www.ttelectronics.com | sensors@ttelectronics.com

Photologic Hermetic Sensors

OPL800, OPL800-OC, OPL801, OPL801-OC, OPL810,
OPL811, OPL811-OC, OPL813-OC, OPL820, OPL820-OC



Obsolete (OPL810-OC, OPL812-OC, OPL821-OC)

Electrical Specifications

Absolute Maximum Ratings ($T_A = 25^\circ\text{C}$ unless otherwise noted)
OPL800/801/810/811/813 and OPL800-OC Series

Output Photologic®	
Voltage at Output Lead OPL800, OPL801, OPL810, OPL811 OPL820	35 V 30 V
Duration of Output Short to V_{CC}	1 second
Power Dissipation OPL800, OPL801 OPL810, OPL811 OPL820	120 mW ⁽²⁾ 250 mW ⁽²⁾ 200 mW ⁽²⁾

Notes:

- (1) RMA flux is recommended. Duration can be extended to 10 sec. max. when flow soldering. For OPL820, a maximum of 20 grams force may be applied to leads while at soldering temperatures.
- (2) Derate linearly 2.5 mW/ $^\circ\text{C}$ above 25 $^\circ\text{C}$ for OPL800, OPL801, OPL810, OPL811. Derate linearly 5.7 mW/ $^\circ\text{C}$ above 90 $^\circ\text{C}$ for OPL820.
- (3) For OPL800, OPL801, OPL810, OPL811, light measurements are made with $\lambda_i = 935\text{ nm}$. For OPL820, light measurements are made with an LED source having a wavelength of 935 nm.

General Note

TT Electronics reserves the right to make changes in product specification without notice or liability. All information is subject to TT Electronics' own data and is considered accurate at time of going to print.

TT Electronics | OPTEK Technology
2900 E. Plano Pkwy, Plano, TX 75074 | Ph: +1 972 323 2200
www.ttelectronics.com | sensors@ttelectronics.com

Photologic Hermetic Sensors

OPL800, OPL800-OC, OPL801, OPL801-OC, OPL810,
OPL811, OPL811-OC, OPL813-OC, OPL820, OPL820-OC



Obsolete (OPL810-OC, OPL812-OC, OPL821-OC)

Electrical Specifications

Electrical Characteristics ($T_A = 25^\circ\text{C}$ unless otherwise noted)

SYMBOL	PARAMETER	MIN	TYP	MAX	UNITS	TEST CONDITIONS
V_{CC}	Operating Supply Voltage					
	OPL800/801	4.5	-	5.5	V	-
	OPL810/811	4.5	-	16	V	-
	OPL820	4.5	-	16	V	-
V_{CC}	Peak-to-Peak V_{CC} Ripple Necessary to Cause False Triggering of Output					
	OPL800/801	-	2	-	V	f = DC to 50 MHz
	OPL810/811	-	-	1	V	f = DC to 50 MHz
I_{CC}	Supply Current	-	-	15	mA	$E_e = 0$ or 1 mW/cm^2
$E_{eT}^{(+)}$	Positive-Going Threshold Irradiance ⁽³⁾					
	OPL800/801	0.050	0.180	0.600	mW/cm^2	$T_A = 25^\circ\text{C}$
	OPL810/811	0.015	0.060	0.200	mW/cm^2	$T_A = 25^\circ\text{C}$
$E_{eT}^{(+)}$	OPL820	0.002	0.015	0.035	mW/cm^2	See below ⁽³⁾
	Hysteresis Ratio					
$E_{eT}^{(+)}/E_{eT}^{(-)}$	OPL800/801	1.5	2.0	2.5	-	-
	OPL810/811	1.2	1.5	2.0	-	-
$E_e^{(+)}/E_e^{(-)}$	Hysteresis Ratio					
	OPL820	1.05	1.20	1.90	-	See below ⁽³⁾
I_{CCH}	High State Supply Current					
	OPL820	-	5	12	mA	See below ⁽⁴⁾
I_{CCL}	Low State Supply Current					
	OPL820	-	4	12	mA	See below ⁽⁵⁾

General Note

TT Electronics reserves the right to make changes in product specification without notice or liability. All information is subject to TT Electronics' own data and is considered accurate at time of going to print.

TT Electronics | OPTEK Technology
2900 E. Plano Pkwy, Plano, TX 75074 | Ph: +1 972 323 2200
www.ttelectronics.com | sensors@ttelectronics.com

Photologic Hermetic Sensors

OPL800, OPL800-OC, OPL801, OPL801-OC, OPL810,
OPL811, OPL811-OC, OPL813-OC, OPL820, OPL820-OC



Obsolete (OPL810-OC, OPL812-OC, OPL821-OC)

Electrical Specifications

Electrical Characteristics ($T_A = 25^\circ\text{C}$ unless otherwise noted)

SYMBOL	PARAMETER	MIN	TYP	MAX	UNITS	TEST CONDITIONS
V_{OH}	High Level Output Voltage					
	OPL800	2.4	-	-	V	$I_{OH} = -800\ \mu\text{A}$, $E_e = 1\ \text{mW}/\text{cm}^2$
	OPL801	2.4	-	-	V	$I_{OH} = -800\ \mu\text{A}$, $E_e = 0$
	OPL810	$V_{CC}-2.1$	-	-	V	$I_{OH} = -1\ \text{mA}$, $E_e = 0.4\ \text{mW}/\text{cm}^2$
	OPL811	$V_{CC}-2.1$	-	-	V	$I_{OH} = -1\ \text{mA}$, $E_e = 0$
OPL820-OC	$V_{CC}-1.5$	-	V_{CC}	V	$I_{OH} = -100\ \mu\text{A}^{(4)}$	

Notes:

- (1) RMA flux is recommended. Duration can be extended to 10 sec. max. when flow soldering. For OPL820, a maximum of 20 grams force may be applied to leads while at soldering temperatures.
- (2) Derate linearly $2.5\ \text{mW}/^\circ\text{C}$ above 25°C for OPL800, OPL801, OPL810, OPL811. Derate linearly $5.7\ \text{mW}/^\circ\text{C}$ above 90°C for OPL820.
- (3) For OPL800, OPL801, OPL810, OPL811, light measurements are made with $\lambda_i = 935\ \text{nm}$. For OPL820, light measurements are made with an LED source having a wavelength of $935\ \text{nm}$.
- (4) High output state limits are valid for $4.5\ \text{V} < V_{CC} < 16\ \text{V}$ and $E_e > 0.035\ \text{mW}/\text{cm}^2$ (OPL820, OPL820-OC).
- (5) Low output state limits are valid for $4.5\ \text{V} < V_{CC} < 16\ \text{V}$ and $E_e < 0.001\ \text{mW}/\text{cm}^2$ (OPL820, OPL820-OC).

General Note

TT Electronics reserves the right to make changes in product specification without notice or liability. All information is subject to TT Electronics' own data and is considered accurate at time of going to print.

TT Electronics | OPTEK Technology
2900 E. Plano Pkwy, Plano, TX 75074 | Ph: +1 972 323 2200
www.ttelectronics.com | sensors@ttelectronics.com

Photologic Hermetic Sensors

OPL800, OPL800-OC, OPL801, OPL801-OC, OPL810,
OPL811, OPL811-OC, OPL813-OC, OPL820, OPL820-OC



Obsolete (OPL810-OC, OPL812-OC, OPL821-OC)

Electrical Specifications

Electrical Characteristics (T_A = 25° C unless otherwise noted)

SYMBOL	PARAMETER	MIN	TYP	MAX	UNITS	TEST CONDITIONS
V _{OH}	High Level Output Voltage					
	OPL800	2.4	-	-	V	I _{OH} = -800 μA, E _e = 1 mW/cm ²
	OPL801	2.4	-	-	V	I _{OH} = -800 μA, E _e = 0
	OPL810	V _{CC} -2.1	-	-	V	I _{OH} = -1 mA, E _e = 0.4 mW/cm ²
	OPL811	V _{CC} -2.1	-	-	V	I _{OH} = -1 mA, E _e = 0
OPL820-OC	V _{CC} -1.5	-	V _{CC}	V	I _{OH} = -100 μA ⁽⁴⁾	
V _{OL}	Low Level Output Voltage					
	OPL800/800-OC	-	-	0.4	V	I _{OL} = 12.8 mA, E _e = 0
	OPL801/801-OC	-	-	0.4	V	I _{OL} = 12.8 mA, E _e = 1 mW/cm ²
	OPL810	-	-	0.4	V	I _{OL} = 16 mA, E _e = 0
	OPL811/811-OC	-	-	0.4	V	I _{OL} = 16 mA, E _e = 0.4 mW/cm ²
	OPL813-OC	-	-	0.4	V	I _{OL} = 16 mA, E _e = 0.2 mW/cm ²
OPL820	-	-	0.4	V	I _{OL} = 16 mA ⁽⁵⁾	
I _{OH}	High Level Output Current					
	OPL800-OC	-	-	100	μA	V _{OH} = 30 V, E _e = 2 mW/cm ²
	OPL801-OC	-	-	100	μA	V _{OH} = 30 V, E _e = 0
	OPL811-OC	-	-	100	μA	V _{OH} = 30 V, E _e = 0
OPL813-OC	-	-	100	μA	V _{OH} = 30 V, E _e = 0	
I _{OS}	Short Circuit Output Current					
	OPL800	-20		-	mA	E _e = 1 mW/cm ² , Output = GND
OPL801	-		-100	mA	E _e = 0, Output = GND	

General Note

TT Electronics reserves the right to make changes in product specification without notice or liability. All information is subject to TT Electronics' own data and is considered accurate at time of going to print.

TT Electronics | OPTEK Technology
2900 E. Plano Pkwy, Plano, TX 75074 | Ph: +1 972 323 2200
www.ttelectronics.com | sensors@ttelectronics.com

Photologic Hermetic Sensors

OPL800, OPL800-OC, OPL801, OPL801-OC, OPL810,
OPL811, OPL811-OC, OPL813-OC, OPL820, OPL820-OC



Obsolete (OPL810-OC, OPL812-OC, OPL821-OC)

Electrical Specifications

Electrical Characteristics ($T_A = 25^\circ\text{C}$ unless otherwise noted)

SYMBOL	PARAMETER	MIN	TYP	MAX	UNITS	TEST CONDITIONS
t_r, t_f	Output Rise Time, Fall Time OPL800/801	-	70	-	ns	$T_A = 25^\circ\text{C}$, $E_e = 0$ or 1 mW/cm^2 , $R_L = 8\text{ TTL loads}$, $f = 10\text{ kHz}$, D.C. = 50 %
	OPL800-OC/801-OC	-	70	-	ns	$T_A = 25^\circ\text{C}$, $E_e = 0$ or 1 mW/cm^2 , $R_L = 360\ \Omega$, $f = 10\text{ kHz}$, D.C. = 50 %
	OPL810/811	-	70	-	ns	$T_A = 25^\circ\text{C}$, $E_e = 0$ or 0.4 mW/cm^2 , $R_L = 10\text{ TTL loads}$, $f = 10\text{ kHz}$, D.C. = 50 %
	OPL811-OC/813-OC	-	100	-	ns	$T_A = 25^\circ\text{C}$, $E_e = 0$ or 1 mW/cm^2 , $R_L = 300\ \Omega$, $f = 10\text{ kHz}$, D.C. = 50 %
	OPL820	-	60	-	ns	$R_L = 390\ \Omega$
t_{PLH}, t_{PHL}	Propagation Delay Low/High - High/Low OPL800/801	-	5	-	μs	$T_A = 25^\circ\text{C}$, $E_e = 0$ or 1 mW/cm^2 , $R_L = 8\text{ TTL loads}$, $f = 10\text{ kHz}$, D.C. = 50 %
	OPL800-OC/801-OC	-	5	-	μs	$T_A = 25^\circ\text{C}$, $E_e = 0$ or 1 mW/cm^2 , $R_L = 8\text{ TTL loads}$, $f = 10\text{ kHz}$, D.C. = 50 %
	OPL810/811	-	5	-	μs	$T_A = 25^\circ\text{C}$, $E_e = 0$ or 0.4 mW/cm^2
	OPL811-OC/813-OC	-	5	-	μs	$R_L = 10\text{ TTL loads}$, $f = 10\text{ kHz}$, D.C. = 50 % $T_A = 25^\circ\text{C}$, $E_e = 0$ or 1 mW/cm^2 ,
	OPL820 (to high state) OPL820 (to low state)	- -	1 2.1	- -	μs μs	$E_e = 0.1\text{ mW/cm}^2$, $R_L = 390\ \Omega$ $E_e = 0.1\text{ mW/cm}^2$, $R_L = 390\ \Omega$
Data Rate	Data Rate Using NRZ Format	-	100	-	kHz	$E_e = 0.1\text{ mW/cm}^2$, $R_L = 390\ \Omega$

Notes:

- (1) RMA flux is recommended. Duration can be extended to 10 sec. max. when flow soldering. For OPL820, a maximum of 20 grams force may be applied to leads while at soldering temperatures.
- (2) Derate linearly $2.5\text{ mW}/^\circ\text{C}$ above 25°C for OPL800, OPL801, OPL810, OPL811. Derate linearly $5.7\text{ mW}/^\circ\text{C}$ above 90°C for OPL820.
- (3) For OPL800, OPL801, OPL810, OPL811, light measurements are made with $\lambda_i = 935\text{ nm}$. For OPL820, light measurements are made with an LED source having a wavelength of 935 nm .
- (4) High output state limits are valid for $4.5\text{ V} < V_{CC} < 16\text{ V}$ and $E_e > 0.035\text{ mW/cm}^2$ (OPL820, OPL820-OC).
- (5) Low output state limits are valid for $4.5\text{ V} < V_{CC} < 16\text{ V}$ and $E_e < 0.001\text{ mW/cm}^2$ (OPL820, OPL820-OC).

General Note

TT Electronics reserves the right to make changes in product specification without notice or liability. All information is subject to TT Electronics' own data and is considered accurate at time of going to print.

TT Electronics | OPTEK Technology
2900 E. Plano Pkwy, Plano, TX 75074 | Ph: +1 972 323 2200
www.ttelectronics.com | sensors@ttelectronics.com

Photologic Hermetic Sensors

OPL800, OPL800-OC, OPL801, OPL801-OC, OPL810,
OPL811, OPL811-OC, OPL813-OC, OPL820, OPL820-OC



Obsolete (OPL810-OC, OPL812-OC, OPL821-OC)

Performance OPL800, OPL801

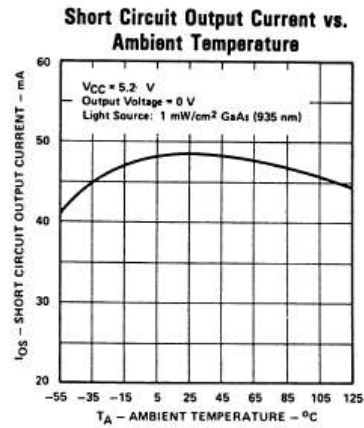
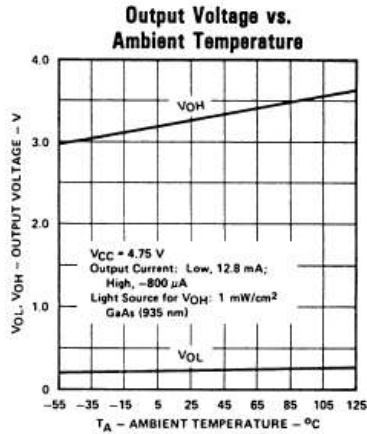

OPL800-OC, OPL801-OC

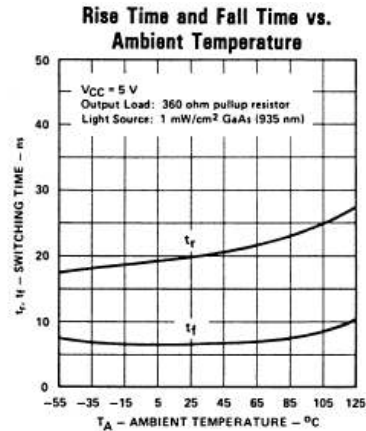
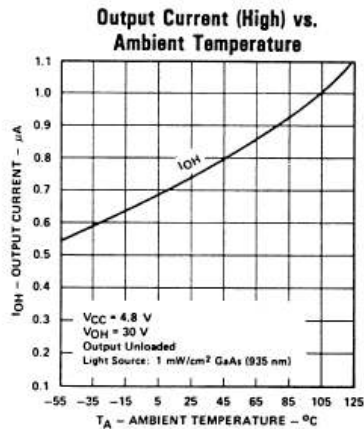

OPL800, OPL800-OC

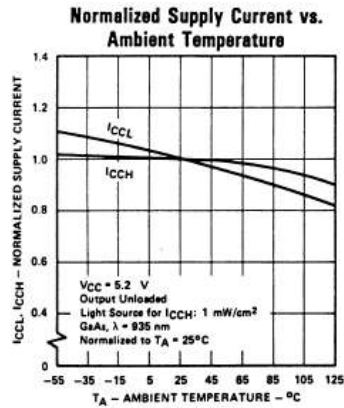

OPL801, OPL801-OC

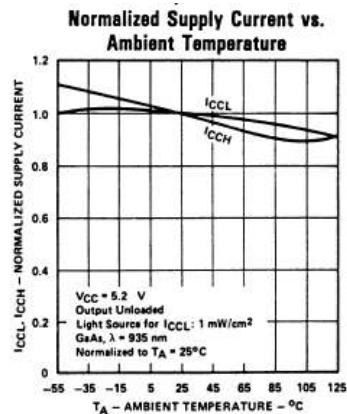

General Note

TT Electronics reserves the right to make changes in product specification without notice or liability. All information is subject to TT Electronics' own data and is considered accurate at time of going to print.

TT Electronics | OPTEK Technology
 2900 E. Plano Pkwy, Plano, TX 75074 | Ph: +1 972 323 2200
www.ttelectronics.com | sensors@ttelectronics.com

Photologic Hermetic Sensors

OPL800, OPL800-OC, OPL801, OPL801-OC, OPL810,
OPL811, OPL811-OC, OPL813-OC, OPL820, OPL820-OC



Obsolete (OPL810-OC, OPL812-OC, OPL821-OC)

Performance

OPL800, OPL801 Series

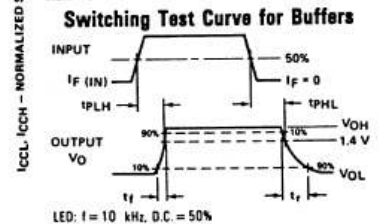
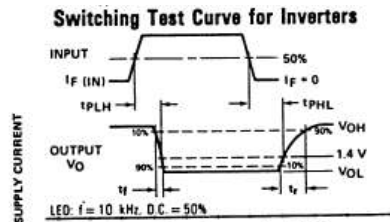
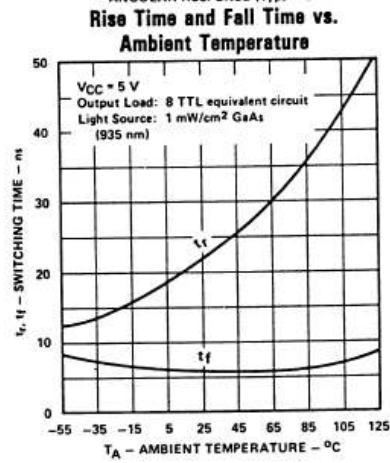
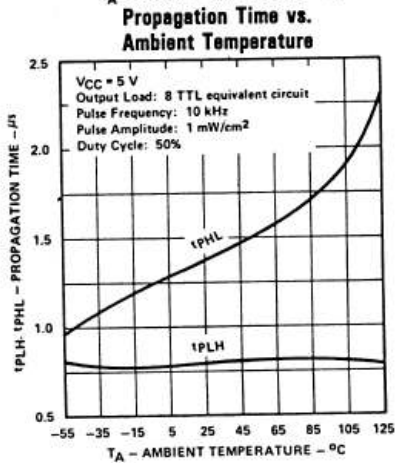
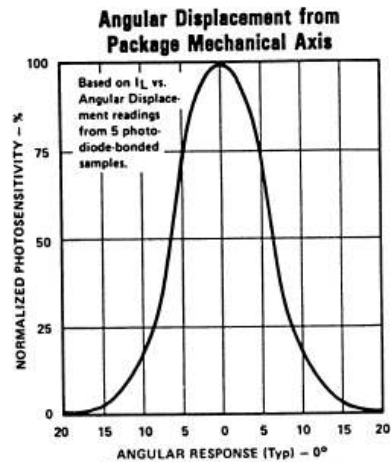
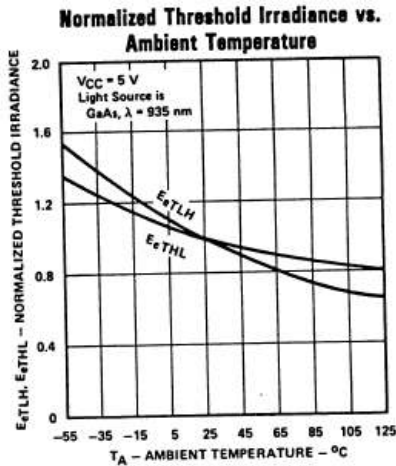

General Note
TT Electronics reserves the right to make changes in product specification without notice or liability. All information is subject to TT Electronics' own data and is considered accurate at time of going to print.

TT Electronics | OPTEK Technology
2900 E. Plano Pkwy, Plano, TX 75074 | Ph: +1 972 323 2200
www.ttelectronics.com | sensors@ttelectronics.com

Photologic Hermetic Sensors

OPL800, OPL800-OC, OPL801, OPL801-OC, OPL810, OPL811, OPL811-OC, OPL813-OC, OPL820, OPL820-OC



Obsolete (OPL810-OC, OPL812-OC, OPL821-OC)

Performance

OPL810, OPL811 Series

Output Voltage vs. Ambient Temp.

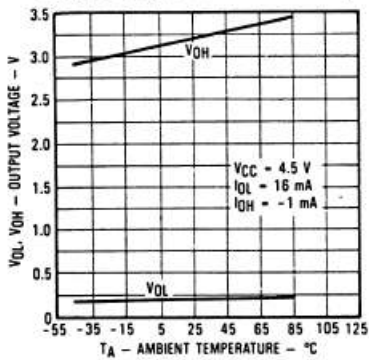

High Output Current vs. Ambient Temp.

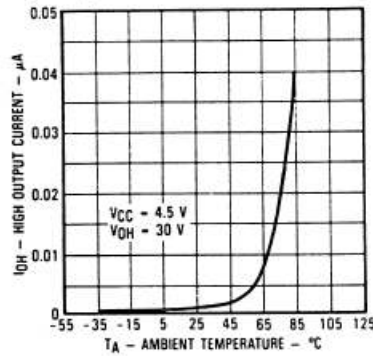

Normalized Threshold Irradiance vs. T_A

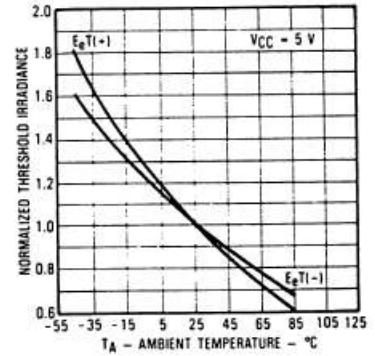

OPL813 Series

Normalized Threshold Irradiance vs. Amb. Temp.

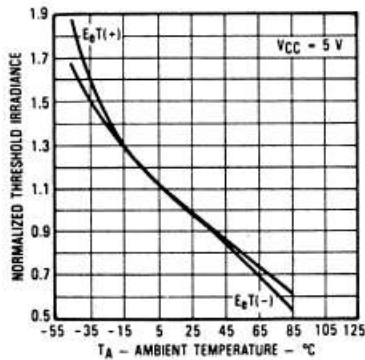

Normalized Spectral Response

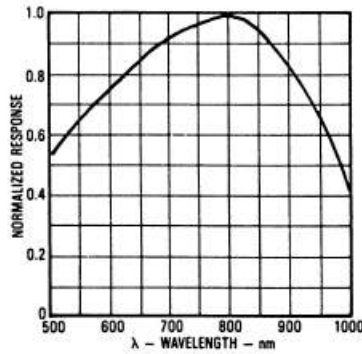

Angular Displacement from Package Mechanical Axis

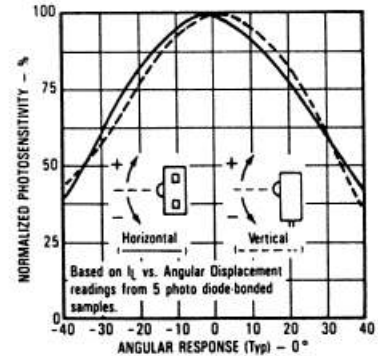

General Note

TT Electronics reserves the right to make changes in product specification without notice or liability. All information is subject to TT Electronics' own data and is considered accurate at time of going to print.

TT Electronics | OPTEK Technology
2900 E. Plano Pkwy, Plano, TX 75074 | Ph: +1 972 323 2200
www.ttelectronics.com | sensors@ttelectronics.com

Photologic Hermetic Sensors

OPL800, OPL800-OC, OPL801, OPL801-OC, OPL810,
OPL811, OPL811-OC, OPL813-OC, OPL820, OPL820-OC



Obsolete (OPL810-OC, OPL812-OC, OPL821-OC)

Performance

OPL813 Series

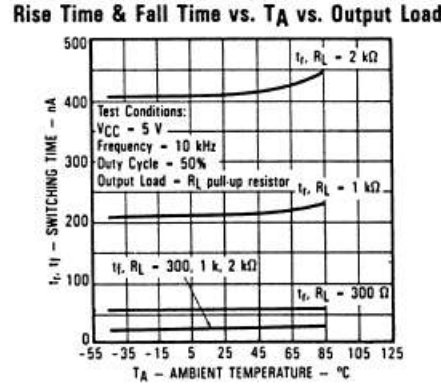
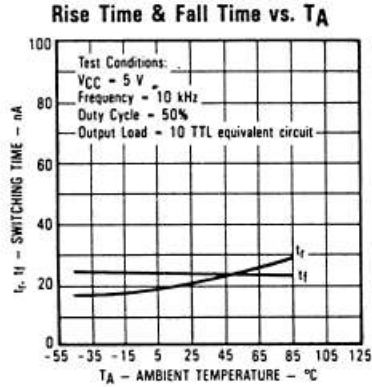
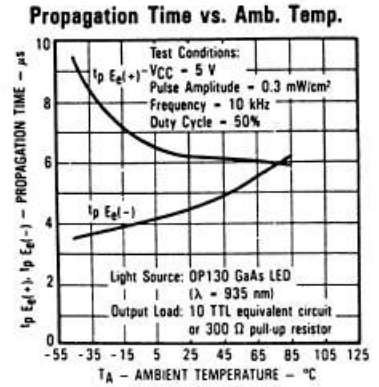
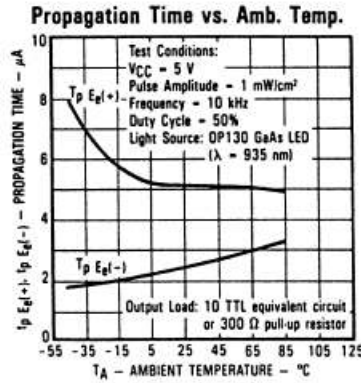
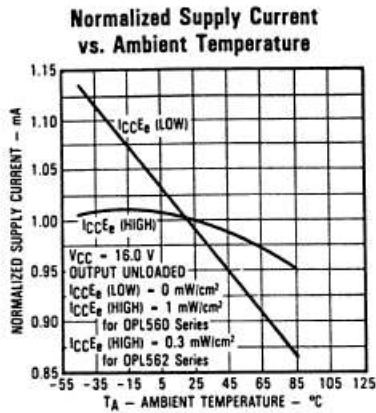

Switching Test Curves

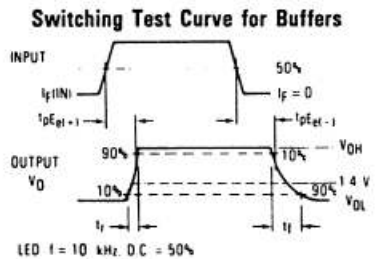
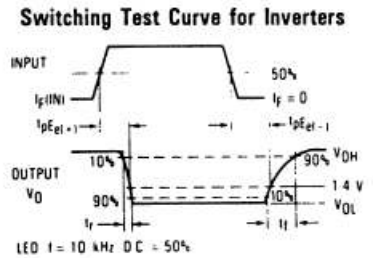

General Note
TT Electronics reserves the right to make changes in product specification without notice or liability. All information is subject to TT Electronics' own data and is considered accurate at time of going to print.

Photologic Hermetic Sensors

OPL800, OPL800-OC, OPL801, OPL801-OC, OPL810,
OPL811, OPL811-OC, OPL813-OC, OPL820, OPL820-OC

Obsolete (OPL810-OC, OPL812-OC, OPL821-OC)



Performance

OPL820 Series

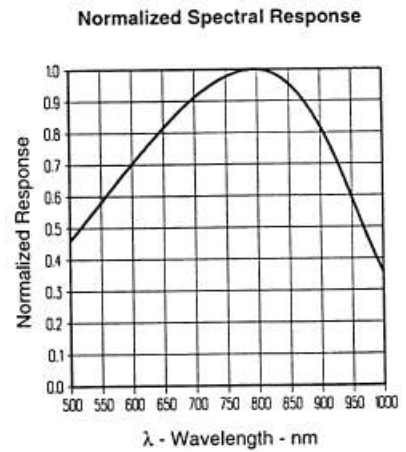
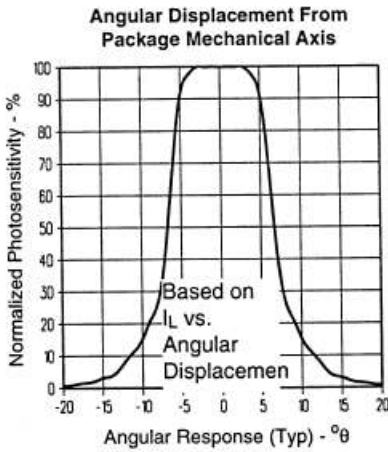
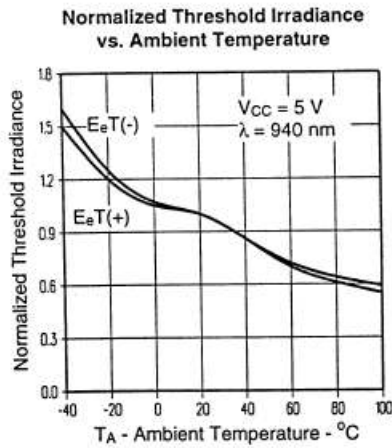

General Note

TT Electronics reserves the right to make changes in product specification without notice or liability. All information is subject to TT Electronics' own data and is considered accurate at time of going to print.

TT Electronics | OPTEK Technology
2900 E. Plano Pkwy, Plano, TX 75074 | Ph: +1 972 323 2200
www.ttelectronics.com | sensors@ttelectronics.com

Photologic Hermetic Sensors

OPL800, OPL800-OC, OPL801, OPL801-OC, OPL810,
OPL811, OPL811-OC, OPL813-OC, OPL820, OPL820-OC



Obsolete (OPL810-OC, OPL812-OC, OPL821-OC)

Performance

OPL820 Series

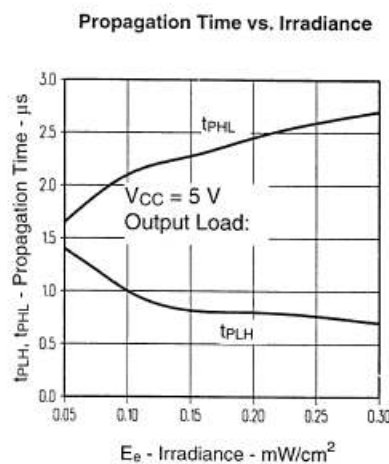
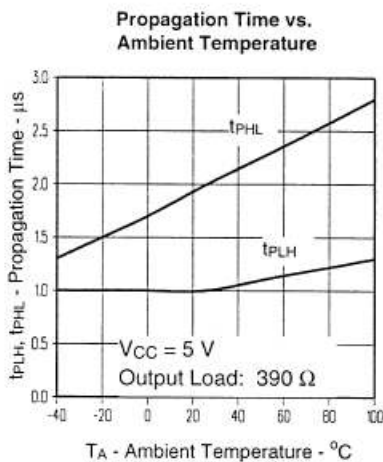
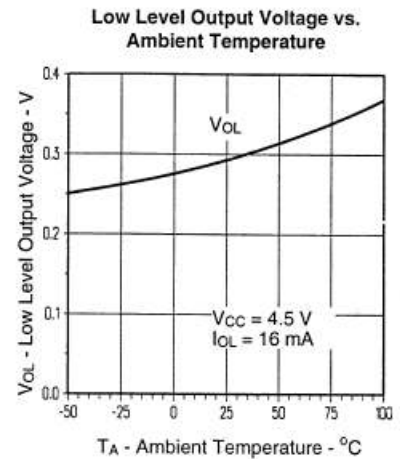
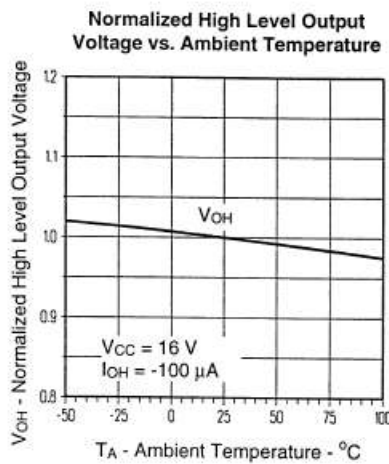
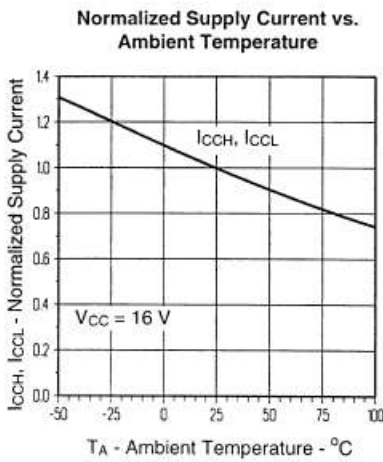

General Note

TT Electronics reserves the right to make changes in product specification without notice or liability. All information is subject to TT Electronics' own data and is considered accurate at time of going to print.

TT Electronics | OPTEK Technology
2900 E. Plano Pkwy, Plano, TX 75074 | Ph: +1 972 323 2200
www.ttelectronics.com | sensors@ttelectronics.com