

# PSI-MOS-RS232/FO 850 T Serial to Fiber Converter

 [perle.com/products/serial-extendrs/psi-mos-rs232-fo850t-rs232-to-dual-fiber.shtml](http://perle.com/products/serial-extendrs/psi-mos-rs232-fo850t-rs232-to-dual-fiber.shtml)

## RS232 to Redundant Fiber

- Two ST type fiber connectors
- Extend serial data up to 2.6 miles
- Immune to EMI, RFI and transient surges
- Point-to-point or star configuration
- Configurable DB9 Male DTE / DCE RS232 Connector

For applications where redundancy is required, the PSI-MOS-RS232/FO 850 T Serial to Fiber Converter transparently connects RS232 devices to two fiber optic cables. By transmitting RS232 data over optical fiber, these serial media converters provide an economical path to extend the reach of serial devices. The serial data input is transmitted out both fiber ports to different locations or back-up systems.



## Expandable Serial to Fiber Network infrastructures

Up to ten (10) Serial to Fiber Converters can be grouped together using the TBUS DIN Rail bus system for voltage and data. This allows the serial converter to operate in additional network topology environments:

- as a star coupler, taking the serial data input signal and distributing it to up to 20 Fiber optic output ports
- linear structure can be used to network several RS-232 devices to form a master/slave structure

## Long Distance Serial Data Transmission over Fiber

RS232 Serial transmission is limited to 20 Kbps for a distance of only 15 meters (50 feet). With the FO 850 T Serial to Fiber Converter serial data transmission can be extended up to 4.2km (2.6 miles). Therefore, any two pieces of asynchronous serial equipment, located miles apart, can communicate at half or full duplex over fiber optic cable at rates up to 115.2 kbps.

## EMI, RFI and Transient Surge Immunity

The FO 850 T fiber optic transmission system electrically isolates connected devices. Electromagnetic interference (EMI) is a common phenomenon in industrial environments. This interference can cause corruption of data over serial or copper-based Ethernet links. However, data transmitted over fiber optic cable is completely immune to this type of noise. This prevents the negative effects of voltage equalization currents and electromagnetic interference on the data cables. A Serial to Fiber Media Converter therefore enables you to inter-connect your serial devices over fiber ensuring optimal data transmission, increased availability of the system, and improved network design flexibility for point-to-point connections, linear networks and star topology networks.

## Flexible Fiber Optic Connections

The FO 850 T operates at 850 nm wavelength, using a separate LED emitter and photo-detector on both ST type connectors. Almost any multimode glass fiber size can be used including 50/125 m, 62.5/125 m, and 200/230 m.

## Power Budget Considerations

Calculating the power budget is critically important when planning the fiber optic link. The optical power budget is the amount of light required to transmit data successfully through a fiber-optic connection. The amount of light energy available within the setup will dictate the length of the fiber optic cable run between serial media converters within the network. Optical power budgets are critical to help businesses avoid signal distortion. [To learn how to calculate optical power budget read our technical note.](#) Transmit and receive dBm can be found in the Hardware specifications.

## High Quality Features and Support

For efficient troubleshooting and less on-site maintenance, the FO 850 T are equipped with comprehensive diagnostic functions to increase system availability, simplify start-up and permanently monitor the optical transmission quality. These cost and time saving features, along with free worldwide technical support, make the FO 850 T RS232 serial to fiber converter the smart choice for IT professionals.

- Connections can be plugged in using a COMBICON screw terminal block
- Supply voltage and data signals routed through via DIN rail connectors
- High-quality electrical isolation between all interfaces (RS-232, fiber optic ports, power supply, DIN rail connector)
- Redundant power supply possible by means of optional system power supply unit
- Approved for use in zone 2
- Floating switch contact for leading alarm generation in relation to critical fiber optic paths
- Intrinsically safe fiber optic interface (Ex op is) for direct connection to devices in zone 1
- Integrated optical diagnostics for continuous monitoring of fiber optic paths
- Automatic data rate detection for all data rates up to 115.2 kbps



RS-232



## PSI-MOS-RS232/FO 850 T Technical Specifications

### Ambient conditions

---

Ambient temperature (operation)	-20 °C ... 60 °C
---------------------------------	------------------

---

Ambient temperature	-40 °C ... 85 °C
---------------------	------------------

(storage/transport)

Permissible humidity (operation) 30 % ... 95 % (non-condensing)

Altitude 5000 m (For restrictions see manufacturer's declaration)

Degree of protection IP20

Noise immunity EN 61000-6-2:2005

### Standards and Regulations

Electromagnetic compatibility Conformance with EMC Directive 2014/30/EU

Type of test Vibration resistance in acc. with EN 60068-2-6/IEC 60068-2-6

Test result 5g, 10-150 Hz, 2.5 h, in XYZ direction

Type of test Shock in acc. with EN 60068-2-27/IEC 60068-2-27

Test result 15g, 11 ms period, half-sine shock pulse

Shock 15g in all directions in acc. with IEC 60068-2-27

Noise emission EN 55011

Noise immunity EN 61000-6-2:2005

Free from substances that could impair the application of coating according to P-VW 3.10.7 57 65 0 VW-AUDI-Seat central standard

Connection in acc. with standard CUL

Standards/regulations  
EN 61000-4-2  
EN 61000-4-3  
EN 61000-4-4  
EN 61000-4-5  
EN 61000-4-6

Vibration (operation) In acc. with IEC 60068-2-6: 5g, 150 Hz

Conformance CE-compliant

ATEX  
II 3 G Ex nA nC IIC T4 Gc X  
II (2) G [Ex op is Gb] IIC (PTB 06 ATEX 2042 U)  
II (2) D [Ex op is Db] IIIC (PTB 06 ATEX 2042 U)

UL, USA/Canada  
Class I, Zone 2, AEx nc IIC T5  
Class I, zone 2, Ex nC nL IIC T5 X  
Class I, Div. 2, Groups A, B, C, D

## Optical interface FO

Number of FO ports	2
Transmit capacity, minimum	-4.6 dBm (200/230 $\mu$ m) -17.6 dBm (50/125 $\mu$ m) -13.6 dBm (62,5/125 $\mu$ m)
Minimum receiver sensitivity	-33.2 dBm
Wavelength	850 nm
Transmission length incl. 3 dB system reserve	2800 m (with F-K 200/230 8 dB/km with quick mounting connector) 4200 m (with F-G 50/125 2.5 dB/km) 4800 m (with F-G 62,5/125 3.0 dB/km)
Transmission medium	PCF fiber Multi-mode fiberglass
Transmission protocol	Transparent to protocol for RS-232 interface
Connection method	B-FOC (duplex ST®)

## General

Transmission channels	2 (1/1), RxD, TxD, full duplex
Bit distortion, input	$\pm$ 35 % (permitted)
Bit distortion, output	< 6.25 %
Electrical isolation	VCC // V.24 (RS-232)
Test voltage data interface/power supply	1.5 kVrms (50 Hz, 1 min.)
Electromagnetic compatibility	Conformance with EMC Directive 2014/30/EU
Noise emission	EN 55011
Net weight	221.1 g
Housing material	PA 6.6-FR
Color	green
MTBF	320 Years (Telcordia standard, 25°C temperature, 21% operating cycle (5 days a week, 8 hours a day)) 48 Years (Telcordia standard, 40°C temperature, 34.25% operating cycle (5 days a week, 12 hours a day))
Conformance	CE-compliant

ATEX	<p>II 3 G Ex nA nC IIC T4 Gc X (Please follow the special installation instructions in the documentation!)</p> <p>II (2) G [Ex op is Gb] IIC (PTB 06 ATEX 2042 U) (Please follow the special installation instructions in the documentation!)</p> <p>II (2) D [Ex op is Db] IIIC (PTB 06 ATEX 2042 U) (Please follow the special installation instructions in the documentation!)</p>
------	---

UL, USA/Canada	<p>Class I, Zone 2, AEx nc IIC T5</p> <p>Class I, zone 2, Ex nC nL IIC T5 X</p> <p>Class I, Div. 2, Groups A, B, C, D</p>
----------------	---

### Digital outputs

Output name	Relay output
-------------	--------------

Output description	Alarm output
--------------------	--------------

Number of outputs	1
-------------------	---

Maximum switching voltage	60 V DC 42 V AC
---------------------------	--------------------

Limiting continuous current	0.46 A
-----------------------------	--------

### Power supply

Nominal supply voltage	24 V DC (With UL approval)
------------------------	----------------------------

Supply voltage range	18 V DC ... 30 V DC
----------------------	---------------------

Max. current consumption	120 mA
--------------------------	--------

Typical current consumption	120 mA (24 V DC)
-----------------------------	------------------

Connection method	COMBICON plug-in screw terminal block
-------------------	---------------------------------------

### Serial interface

Interface 1	V.24 (RS-232) interface in acc. with ITU-T V.28, EIA/TIA-232, DIN 66259-1
-------------	---

Connection method	D-SUB 9 plug
-------------------	--------------

Transmission medium	Copper
---------------------	--------

Transmission length	≤ 15 m
---------------------	--------

Conductor cross section solid min.	0.2 mm <sup>2</sup>
------------------------------------	---------------------

Conductor cross section solid max.	2.5 mm <sup>2</sup>
------------------------------------	---------------------

Conductor cross section flexible min.	0.2 mm <sup>2</sup>
---------------------------------------	---------------------

Conductor cross section flexible max.	2.5 mm <sup>2</sup>
Conductor cross section AWG min.	24
Conductor cross section AWG max.	14
Serial transmission speed	115.2 kbps (NRZ)

**Dimensions**

Width	35 mm
Height	99 mm
Depth	105 mm

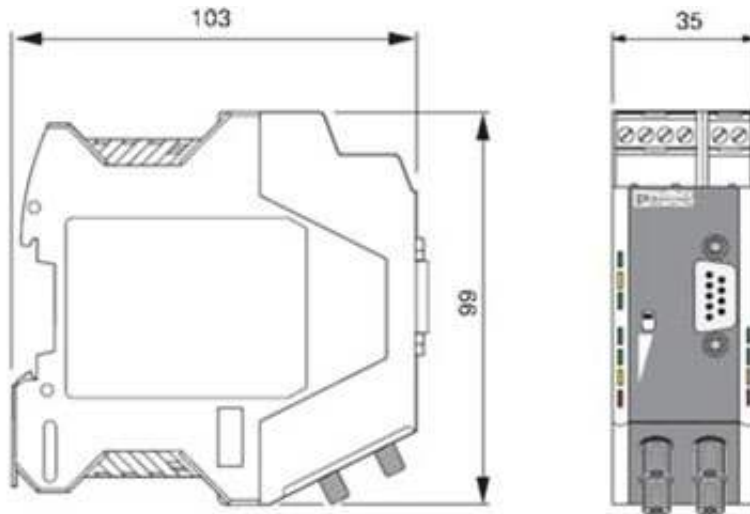

**Environmental Product Compliance**

China RoHS	Environmentally Friendly Use Period = 50
Reach and RoHS Compliant	<a href="#">Reach and RoHS Compliant</a>

**Approvals**

cUL Listed  
cULus Listed  
UL Listed  
ATEX  
EAC  
DNV  
cUL Recognized  
cULus Recognized  
UL Recognized

---

**Commercial data**

---

Packing unit	1
Weight per piece	222.7 g
Country of origin	Germany
Warranty	1 Year

---

**Classifications**

---

eCl@ss 4.0	27230207
eCl@ss 4.1	27230207
eCl@ss 5.0	27230207
eCl@ss 5.1	27230207
eCl@ss 6.0	27230207
eCl@ss 7.0	27230207
eCl@ss 8.0	19179290
eCl@ss 9.0	19179290
ETIM 2.0	EC001423
ETIM 3.0	EC001423
ETIM 4.0	EC001423
ETIM 5.0	EC000310
ETIM 6.0	EC000310
UNSPSC 6.01	30211506
UNSPSC 7.0901	39121008

---

UNSPSC 11 39121008

UNSPSC 12.01 39121008

UNSPSC 13.2 43222604

---

### PSI-MOS-RS232/FO 850 T Serial to Fiber Media Converter Applications

---

- near heavy electrical equipment
- in environments with electrical (EMI) or radio (RFI) interference
- in environments with transient surges
- in industrial plants, warehouses and factory floors
- enabling asynchronous serial equipment to communicate at half or full duplex, with rates up to 115.2 kbps, over optical fiber

---

### Redundant Point-to-point connections between serial devices over fiber

---

Configure the point-to-point connection redundantly to increase availability by using two PSI-MOS-RS232/FO 850 T Serial to Fiber Converters. Easily convert a data link from a single copper cable out to two fiber optic cables.

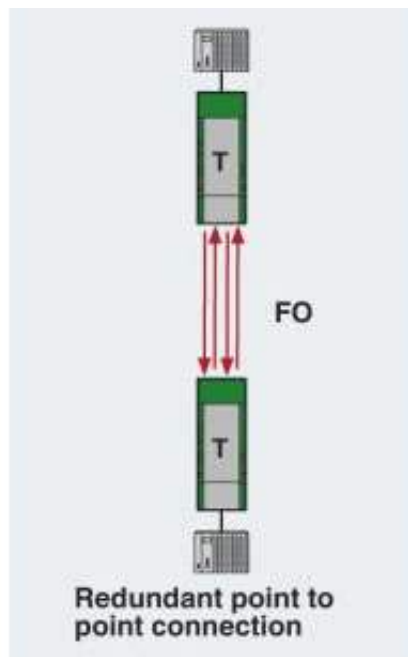

---

### Linear Networks

---

The fiber optic linear structure can be used to network several RS-232 devices to form a master/slave structure. In this case, it must be possible to address all the RS-232 devices via communication software. PSI-MOS-RS232/FO 850 E serial to fiber converters are used at the beginning and end of the fiber optic line. PSI-MOS-RS232/FO 850 T serial to fiber converters with two fiber optic ports are used along the line.



You can use up to ten PSI-MOS-RS232/FO devices along the line in a linear structure.

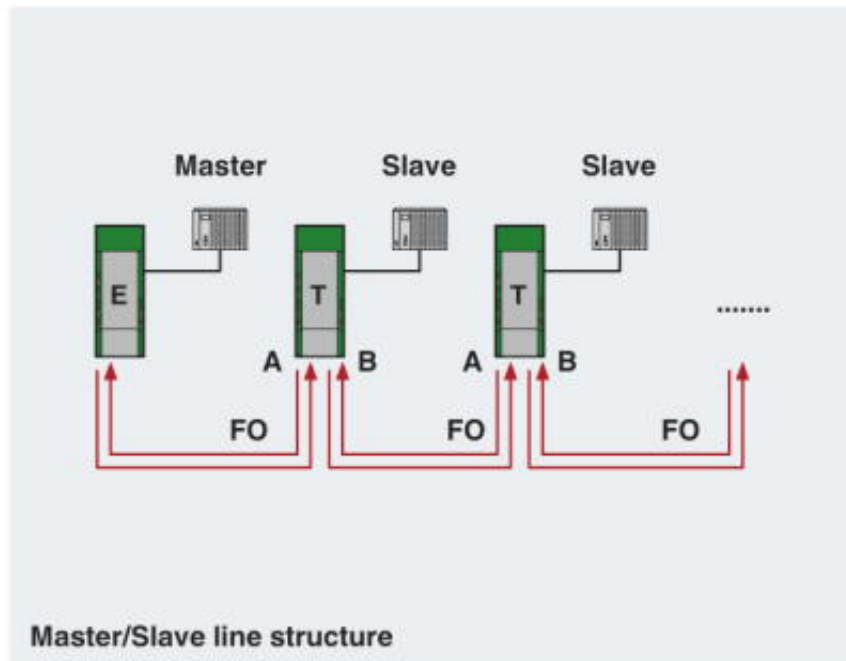

### Redundant Star Networks

You can network RS-232 devices within a star structure as a master/slave network. Depending on the number of star lines required, several PSI-MOS-RS232/FO 850 T Serial to Fiber Converters are connected to TBUS DIN Rail bus systems for voltage and data. This makes up to 20 fiber optic ports available. Cross-wiring for RS-232 data and for the supply voltage is provided automatically by the DIN rail connector.

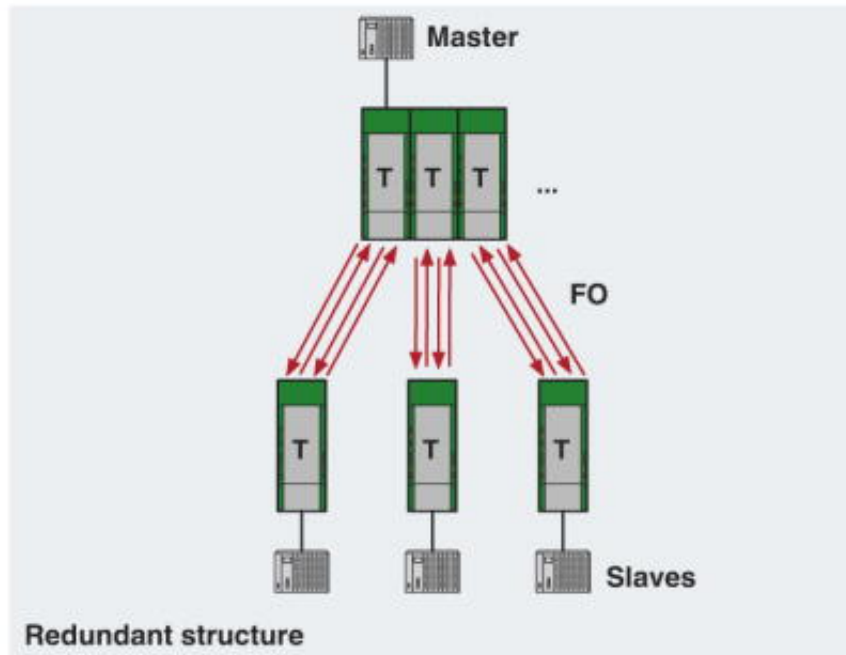

### Block Diagram

