

THIS DRAWING IS UNPUBLISHED. RELEASED FOR PUBLICATION  
 © COPYRIGHT BY TYCO ELECTRONICS CORPORATION. ALL RIGHTS RESERVED.

CABLE ENTRY DIA. MIN.		LOC	DIST	REVISIONS					
HOUSING	.089	AJ	00	P	LTR	DESCRIPTION	DATE	DWN	APVD
CONTACT	.021			B		REV PER ECO 07-027471	1/16/2008	DW	JL

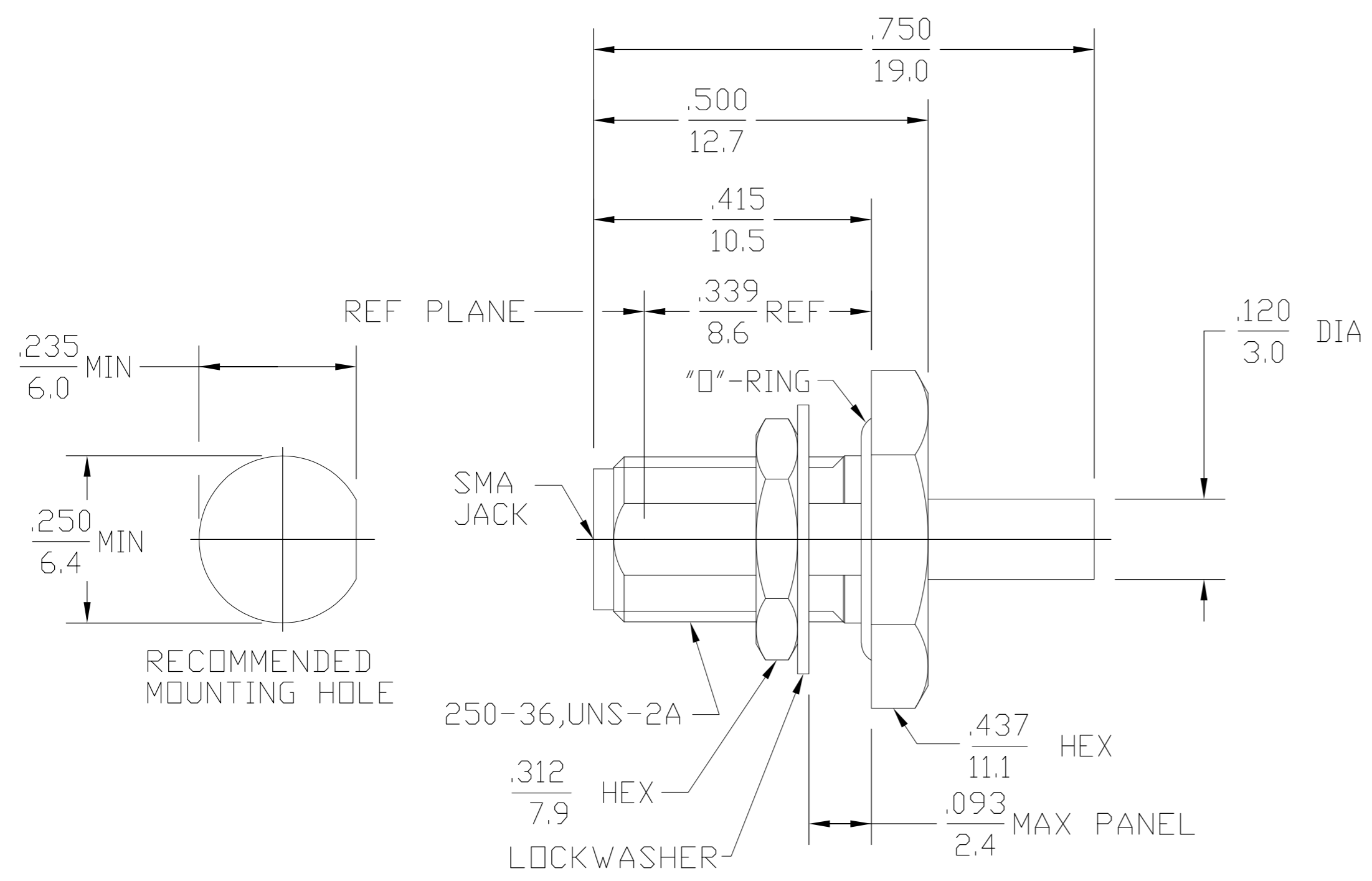

NOTE: DESIGN FOR USE WITH .085 DIA SEMI-RIGID CABLE

### DESIGN CONTROL REQUIRED

1046276-1  
PART NUMBER

ELECTRICAL	MECHANICAL	ENVIRONMENTAL
Nominal Impedance (Ω) <u>50</u>	Interface Dimensions MIL-STD-348, Fig. <u>310.2</u>	TEMPERATURE RATING <u>-65°C TO +105°C</u>
Frequency Range (GHz) DC to <u>18</u>	Recommended Mating Torque <u>7-10 INLBS</u>	Vibration MIL-STD-202, Method 204, Condition D
Volt Rating (VRMS MAX) @ Sea Level <u>335</u>	Mating Characteristics: Insertion (MAX Lbs) <u>3.0</u>	Shock MIL-STD-202, Method 213, Condition I
VSWR <u>1.07 + .008 f(GHz)</u>	Withdrawal (MIN Ωz) <u>1.0</u>	Thermal Shock MIL-STD-202, Method 107, Condition B
Insertion Loss (dB MAX) <u>.03 √f(GHz)</u>	Force to Engage and Disengage (In/Lbs MAX) <u>2.0</u>	EXCEPT HIGH TEMP <u>+115°C</u>
RF Leakage (dB MIN) <u>-90 @ 2 to 3 (GHz)</u>	Center Contact Captivation Axial (Lbs) <u>N/A</u>	Moisture Resistance MIL-STD-202, Method 106, Insulation Resistance Shall Be 200 Megohms min within 5 Minutes After Removal From Humidity
Corona, 70,000 Ft (VRMS MIN) <u>250</u>	Radial (In/Ωz) <u>N/A</u>	Corrosion - MIL-STD-202, Method 101, Condition B, 5% salt spray
Dielectric Withstanding Voltage (VRMS MIN) @ Sea Level <u>1000</u>	Cable Retention Axial Force (Lbs) <u>30</u>	
Contact Resistance (Milliohms MAX) Center Contact <u>3.0</u>	Torque (In/Ωz) <u>16</u>	
Outer Contact <u>2.0</u>	Weight (Grams) <u>3.5</u>	
Cable to Housing <u>0.5</u>		
RF High Potential @ Sea Level (VRMS MIN @ 5 MHz) <u>670</u>		
I.R.(Megohms MIN) <u>10,000</u>		

COMPONENT	MATERIAL	FINISH
HOUSING MOUNTING NUT	STAINLESS STEEL PER ASTM-A484 AND ASTM-A582, TYPE 303	GOLD PLATE PER MIL-G-45204
DIELECTRIC	TFE FLUOROCARBON PER ASTM-D-1457	N/A
CENTER CONTACT	BERYLLIUM COPPER PER ASTM-B-196 OR ASTM-B-197, ALLOY C17300, CONDITION H	GOLD PLATE PER MIL-G-45204
LOCKWASHER	PHOSPHOR BRONZE PER QQ-B-750, GRADE B2 OR TIN BRASS PER ASTM-B-591	GOLD PLATE PER MIL-G-45204
GASKET	SILICONE RUBBER PER ZZ-R-765	N/A

THIS DRAWING IS A CONTROLLED DOCUMENT.

DWN	D.CAMELIO	4/3/95
CHK	-	-
APVD	D.CAMELIO	4/3/95
PRODUCT SPEC	-	-
APPLICATION SPEC	408-04769	-
WEIGHT	-	-
CUSTOMER DRAWING	SCALE 1:1	SHEET 1 of 1

**Tyco Electronics** Tyco Electronics Corporation  
Harrisburg, PA 17105-3608

NAME: SMA STRAIGHT BULKHEAD FEEDTHROUGH CABLE JACK DIRECT SOLDER ATTACHMENT (1250-1754-00)

SIZE: A2 CAGE CODE: 00779 DRAWING NO: 1046276-1 RESTRICTED TO: -