

1. SCOPE

1.1 Scope. This drawing forms a part of a one part - one part number documentation system (see 6.6 herein). Two product assurance classes consisting of military high reliability (device classes Q and M) and space application (device class V), and a choice of case outlines and lead finishes are available and are reflected in the Part or Identifying Number (PIN). Device class M microcircuits represent non-JAN class B microcircuits in accordance with 1.2.1 of MIL-STD-883, "Provisions for the use of MIL-STD-883 in conjunction with compliant non-JAN devices". When available, a choice of Radiation Hardness Assurance (RHA) levels are reflected in the PIN.

1.2 PIN. The PIN shall be as shown in the following example:

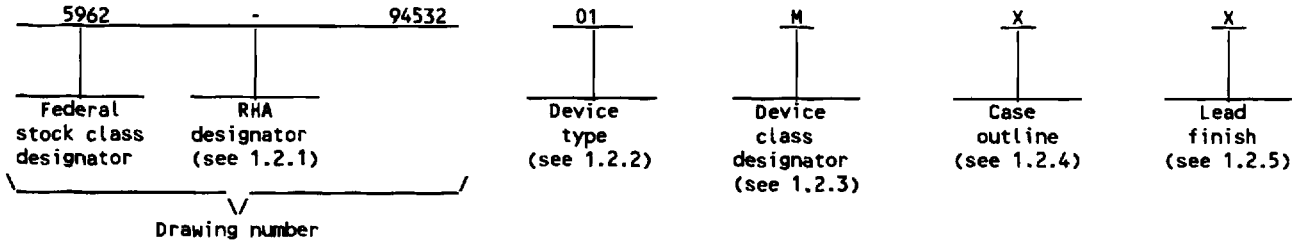

1.2.1 RHA designator. Device class M RHA marked devices shall meet the MIL-I-38535 appendix A specified RHA levels and shall be marked with the appropriate RHA designator. Device classes Q and V RHA marked devices shall meet the MIL-I-38535 specified RHA levels and shall be marked with the appropriate RHA designator. A dash (-) indicates a non-RHA device.

1.2.2 Device type(s). The device type(s) shall identify the circuit function as follows:

<u>Device type</u>	<u>Generic number</u>	<u>Circuit function</u>
01	80860-25	25 MHz - 64-Bit Microprocessor
02	80860-33	33 MHz - 64-Bit Microprocessor
03	80860-40	40 MHz - 64-Bit Microprocessor

1.2.3 Device class designator. The device class designator shall be a single letter identifying the product assurance level as follows:

<u>Device class</u>	<u>Device requirements documentation</u>
M	Vendor self-certification to the requirements for non-JAN class B microcircuits in accordance with 1.2.1 of MIL-STD-883
Q or V	Certification and qualification to MIL-I-38535

1.2.4 Case outline(s). The case outline(s) shall be as designated in MIL-STD-1835 and as follows:

<u>Outline letter</u>	<u>Descriptive designator</u>	<u>Terminals</u>	<u>Package style</u>
X	CMGA9-P168	168	168 Lead - Ceramic PGA
Y	See figure 1	196	196 Lead - Ceramic QFP

1.2.5 Lead finish. The lead finish shall be as specified in MIL-STD-883 (see 3.1 herein) for class M or MIL-I-38535 for classes Q and V. Finish letter "X" shall not be marked on the microcircuit or its packaging. The "X" designation is for use in specifications when lead finishes A, B, and C are considered acceptable and interchangeable without preference.

STANDARDIZED MILITARY DRAWING DEFENSE ELECTRONICS SUPPLY CENTER DAYTON, OHIO 45444	SIZE A		5962-94532
		REVISION LEVEL	SHEET 2

1.3 Absolute maximum ratings. 1/

Storage Temperature Range	-65°C to +150°C
Supply voltage with respect to ground	-0.5 to 6.5V
Voltage on any pin with respect to ground	-0.5 to 6.5V
Maximum power dissipation (P _D)	3.5 W
Lead Temperature (soldering 10 seconds)	+300°C
Thermal Resistance, Junction-to-case (θ _{JC})	
Case X	1.5°C/W
Case Y	1.5°C/W
Junction Temperature (T _J)	150°C

1.4 Recommended operating conditions.

Case Operating Temperature Range (T _C)	-55°C to +125°C
Supply Voltage, V _{CC}	4.75 to 5.25V

1.5 Digital logic testing for device classes Q and V.

Fault coverage measurement of manufacturing logic tests (MIL-STD-883, test method 5012) percent 2/

2. APPLICABLE DOCUMENTS

2.1 Government specification, standards, bulletin, and handbook. Unless otherwise specified, the following specification, standards, bulletin, and handbook of the issue listed in that issue of the Department of Defense Index of Specifications and Standards specified in the solicitation, form a part of this drawing to the extent specified herein.

SPECIFICATION

MILITARY

MIL-I-38535 - Integrated Circuits, Manufacturing, General Specification for.

STANDARDS

MILITARY

MIL-STD-883 - Test Methods and Procedures for Microelectronics.
MIL-STD-973 - Configuration Management.
MIL-STD-1835 - Microcircuit Case Outlines.

BULLETIN

MILITARY

MIL-BUL-103 - List of Standardized Military Drawings (SMD's).

HANDBOOK

MILITARY

MIL-HDBK-780 - Standardized Military Drawings.

(Copies of the specification, standards, bulletin, and handbook required by manufacturers in connection with specific acquisition functions should be obtained from the contracting activity or as directed by the contracting activity.)

2.2 Order of precedence. In the event of a conflict between the text of this drawing and the references cited herein, the text of this drawing shall take precedence.

1/ Stresses above the absolute maximum rating may cause permanent damage to the device. Extended operation at the maximum levels may degrade performance and affect reliability.

2/ Values will be added when they become available.

STANDARDIZED MILITARY DRAWING DEFENSE ELECTRONICS SUPPLY CENTER DAYTON, OHIO 45444	SIZE A		5962-94532
		REVISION LEVEL	SHEET 3

3. REQUIREMENTS

3.1 Item requirements. The individual item requirements for device class M shall be in accordance with 1.2.1 of MIL-STD-883, "Provisions for the use of MIL-STD-883 in conjunction with compliant non-JAN devices" and as specified herein. The individual item requirements for device classes Q and V shall be in accordance with MIL-I-38535, the device manufacturer's Quality Management (QM) plan, and as specified herein.

3.2 Design, construction, and physical dimensions. The design, construction, and physical dimensions shall be as specified in MIL-STD-883 (see 3.1 herein) for device class M and MIL-I-38535 for device classes Q and V and herein.

3.2.1 Case outline(s). The case outline(s) shall be in accordance with 1.2.4 herein and figure 1.

3.2.2 Terminal connections. The terminal connections shall be as specified on figure 2.

3.2.3 Functional block diagram(s). The functional block diagram(s) shall be as specified on figure 3.

3.3 Electrical performance characteristics and postirradiation parameter limits. Unless otherwise specified herein, the electrical performance characteristics and postirradiation parameter limits are as specified in table I and shall apply over the full case operating temperature range.

3.4 Electrical test requirements. The electrical test requirements shall be the subgroups specified in table II. The electrical tests for each subgroup are defined in table I.

3.5 Marking. The part shall be marked with the PIN listed in 1.2 herein. Marking for device class M shall be in accordance with MIL-STD-883 (see 3.1 herein). In addition, the manufacturer's PIN may also be marked as listed in MIL-BUL-103. Marking for device classes Q and V shall be in accordance with MIL-I-38535.

3.5.1 Certification/compliance mark. The compliance mark for device class M shall be a "C" as required in MIL-STD-883 (see 3.1 herein). The certification mark for device classes Q and V shall be a "QML" or "Q" as required in MIL-I-38535.

3.6 Certificate of compliance. For device class M, a certificate of compliance shall be required from a manufacturer in order to be listed as an approved source of supply in MIL-BUL-103 (see 6.7.2 herein). For device classes Q and V, a certificate of compliance shall be required from a QML-38535 listed manufacturer in order to supply to the requirements of this drawing (see 6.7.1 herein). The certificate of compliance submitted to DESC-EC prior to listing as an approved source of supply for this drawing shall affirm that the manufacturer's product meets, for device class M, the requirements of MIL-STD-883 (see 3.1 herein), or for device classes Q and V, the requirements of MIL-I-38535 and the requirements herein.

3.7 Certificate of conformance. A certificate of conformance as required for device class M in MIL-STD-883 (see 3.1 herein) or for device classes Q and V in MIL-I-38535 shall be provided with each lot of microcircuits delivered to this drawing.

3.8 Notification of change for device class M. For device class M, notification to DESC-EC of change of product (see 6.2 herein) involving devices acquired to this drawing is required for any change as defined in MIL-STD-973.

3.9 Verification and review for device class M. For device class M, DESC, DESC's agent, and the acquiring activity retain the option to review the manufacturer's facility and applicable required documentation. Offshore documentation shall be made available onshore at the option of the reviewer.

3.10 Microcircuit group assignment for device class M. Device class M devices covered by this drawing shall be in microcircuit group number 105 (see MIL-I-38535, appendix A).

4. QUALITY ASSURANCE PROVISIONS

4.1 Sampling and inspection. For device class M, sampling and inspection procedures shall be in accordance with MIL-STD-883 (see 3.1 herein). For device classes Q and V, sampling and inspection procedures shall be in accordance with MIL-I-38535 and the device manufacturer's QM plan.

STANDARDIZED MILITARY DRAWING DEFENSE ELECTRONICS SUPPLY CENTER DAYTON, OHIO 45444	SIZE A		5962-94532
		REVISION LEVEL	SHEET 4

TABLE I. Electrical performance characteristics.

Test	Symbol	Conditions -55°C ≤ T _C ≤ +125°C 4.75V ≤ V _{CC} ≤ 5.25V 1/	Group A subgroups	Device Type	Limits		Unit
					Min	Max	
Input LOW voltage	V _{IL}		1,2,3	all	-0.3 2/	0.8	V
Input HIGH voltage	V _{IH}		1,2,3	all	2.0	V _{CC} +0.3 2/	V
CLK input LOW voltage	V _{ILC}		1,2,3	all	-0.3 2/	0.8	V
CLK input HIGH voltage	V _{IHC}		1,2,3	all	3.0	V _{CC} +0.3 2/	V
Output LOW voltage	V _{OL}	I _{OL} =4.0mA for A31-A3, D63- D0, BE7 - BE0 I _{OL} =5.0mA all other outputs	1,2,3	all		0.45	V
Output HIGH voltage	V _{OH}	I _{OH} =1.0mA for A31-A3, D63- D0, BE7 - BE0 I _{OH} =0.9mA all other outputs	1,2,3	all	2.4		V
Input leakage current	I _{LI}	No pullup/pulldown V _{CC} = 5.25 V	1,2,3	all		±15	μA
Output leakage current	I _{LO}	V _{CC} = 5.25 V	1,2,3	all		±15	μA
Power supply current	I _{CC}	V _{CC} = 5.0 V	1,2,3	01,02 03		600 650	mA
Input capacitance	C _{IN}	2/ f = 25, 33, 40 Mhz See 4.4.1c	4	all		15	pF
I/O or output capacitance	C _O	2/	4	all		15	pF
Clock capacitance	C _{CLK}	2/		all		20	pF
Functional testing		V _{CC} = 4.75 V, See 4.4.1d	7, 8	all			

See footnotes at end of table.

STANDARDIZED
MILITARY DRAWING
DEFENSE ELECTRONICS SUPPLY CENTER
DAYTON, OHIO 45444

SIZE
A

5962-94532

REVISION LEVEL

SHEET

5

TABLE I. Electrical performance characteristics - Continued.

Test	Symbol	Conditions -55°C ≤ T _C ≤ +125°C 4.75V ≤ V _{CC} ≤ 5.25V 1/	Group A subgroups	Device Type	Limits		Unit
					Min	Max	
CLK Period	t1		9,10,11	01 02 03	40 30 25	125 125 125	ns
CLK High Time 2/	t2	at 3V	9,10,11	01 02 03	10 7 5		ns
CLK Low Time 2/	t3	at 0.8V	9,10,11	01 02 03	10 7 5		ns
CLK Fall Time 2/	t4	3V-0.8V	9,10,11	all		7	ns
CLK Rise Time 2/	t5	0.8V-3V	9,10,11	all		7	ns
A31-A3, PTB, W/R, NENE Valid Delay	t6a	50 pF load	9,10,11	01 02 03	3.5 3.5 3.5	43 23 21	ns
BE7 - BE0 Valid Delay	t6b	50 pF load	9,10,11	01,02 03	3.5 3.5	25 23	ns
Float Time, All Outputs 3/	t7		9,10,11	01 02 03	3.5 3.5 3.5	40 30 25	ns
ADS, BREQ, LOCK, HLDA Valid Delay	t8	50 pF load	9,10,11	01 02 03	3.5 3.5 3.5	29 20 15	ns
D63-D0 Valid Delay	t9	50 pF load	9,10,11	01 02 03	3.5 3.5 3.5	60 35 33	ns
Setup Time, All Inputs except DATA	t10a	4/	9,10,11	01 02 03	16 11 8		ns
Hold Time, All Inputs except DATA	t11a	4/	9,10,11	01 02 03	7 4 3		ns
DATA Setup Time	t10b		9,10,11	01 02 03	16 11 10		ns
DATA Hold Time	t11b		9,10,11	01 02 03	7 4 3		ns

NOTES:

- 1/ The following pins are active low: $\overline{\text{BE0}}$ - $\overline{\text{BE7}}$, $\overline{\text{LOCK}}$, $\overline{\text{W/R}}$, $\overline{\text{NENE}}$, $\overline{\text{NA}}$, $\overline{\text{READY}}$, $\overline{\text{ADS}}$, $\overline{\text{KEN}}$.
Unless otherwise specified all test conditions are worst case condition.
- 2/ Tested initially and at process and design changes. Thereafter guaranteed, if not tested, to the limits specified in table I.
- 3/ Float condition occurs when maximum output current becomes less than I_{LO} in magnitude. Float delay is not tested.
- 4/ INT and HOLD are asynchronous inputs. The setup and hold specifications are given for test purposes or to assure recognition on a specific rising edge of CLK.

STANDARDIZED MILITARY DRAWING DEFENSE ELECTRONICS SUPPLY CENTER DAYTON, OHIO 45444	SIZE A		5962-94532
		REVISION LEVEL	SHEET 6

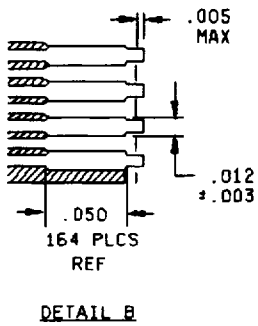
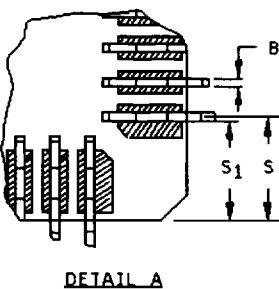
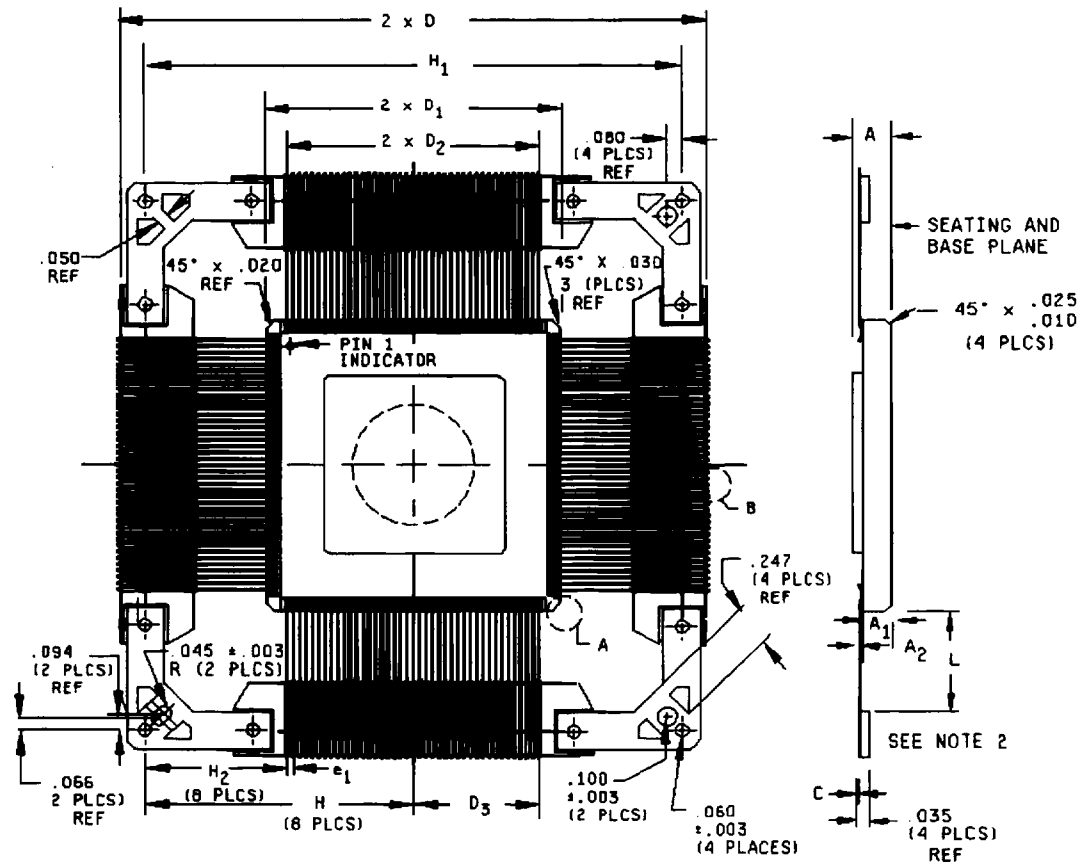

Inches	mm
.003	0.08
.005	0.13
.010	0.25
.012	0.30
.020	0.51
.025	0.64
.030	0.76
.035	0.89
.045	1.14
.050	1.27
.060	1.52
.066	1.68
.060	2.03
.094	2.39
.247	6.27

Case Y
 FIGURE 1. Case Outlines.

STANDARDIZED MILITARY DRAWING DEFENSE ELECTRONICS SUPPLY CENTER DAYTON, OHIO 45444	SIZE A		5962-94532
		REVISION LEVEL	SHEET 7

Symbol	Millimeters			Inches		
	Min	Max	Notes	Min	Max	Notes
A	2.23	2.92	Solid lid	0.088	0.115	Solid lid
A ₁	1.96	2.39		0.077	0.094	
B	0.20	0.25		0.008	0.010	
C	0.10	0.20		0.004	0.008	
D	63.50	64.01		2.500	2.520	
D ₁	33.65	34.16		1.325	1.345	
D ₂	30.48 Basic			1.200 Basic		
e ₁	0.58	0.69		0.023	0.027	
H	29.21 Basic			1.150 Basic		
H ₁	58.42 Basic			2.30 Basic		
H ₂	19.05 Basic			0.750 Basic		
L	9.27	10.03		0.365	0.395	
N	196			196		
S	1.270	2.03	Reference	0.050	0.080	Reference
S ₁	1.14	1.93	Reference	0.045	0.076	Reference
Issue	IWS 7/90					

Case Y

FIGURE 1. Case Outlines - continued.

STANDARDIZED MILITARY DRAWING DEFENSE ELECTRONICS SUPPLY CENTER DAYTON, OHIO 45444	SIZE A		5962-94532
		REVISION LEVEL	SHEET 8

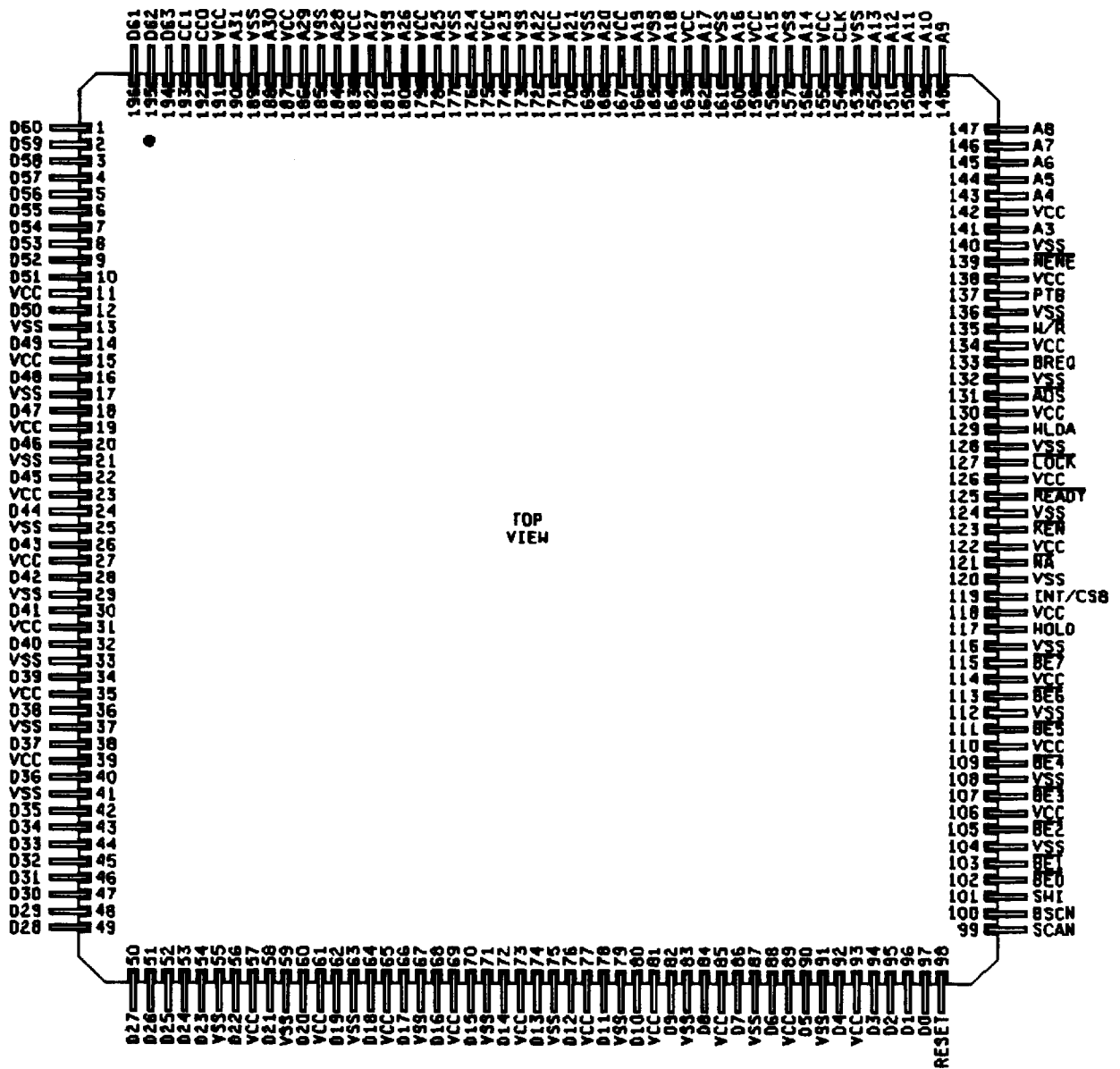

TOP VIEW

Case Y

FIGURE 2. Terminal Connections - Continued

STANDARDIZED MILITARY DRAWING DEFENSE ELECTRONICS SUPPLY CENTER DAYTON, OHIO 45444	SIZE A		5962-94532
		REVISION LEVEL	SHEET 10

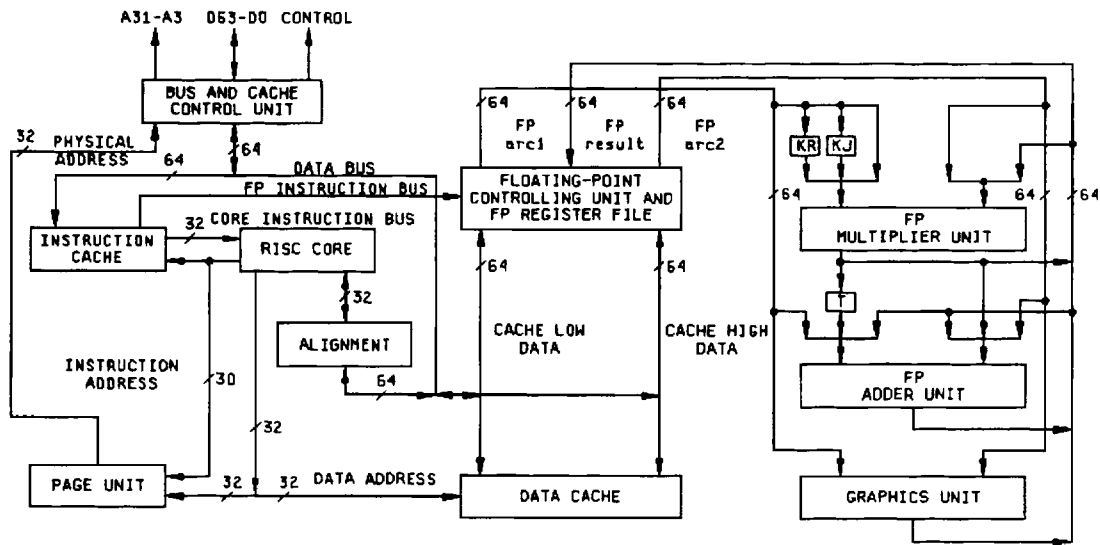

FIGURE 3. Functional block diagram.

STANDARDIZED MILITARY DRAWING DEFENSE ELECTRONICS SUPPLY CENTER DAYTON, OHIO 45444	SIZE A		5962-94532
		REVISION LEVEL	SHEET 11

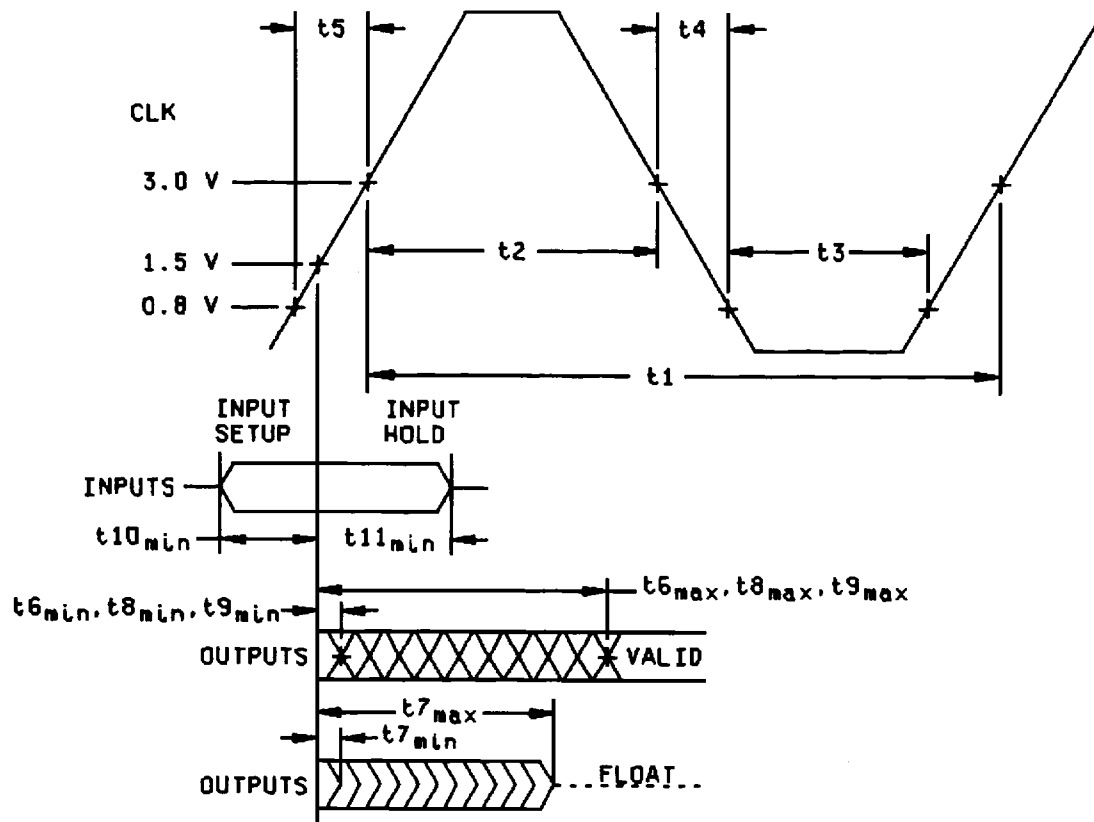

FIGURE 4. Timing waveforms.

STANDARDIZED MILITARY DRAWING DEFENSE ELECTRONICS SUPPLY CENTER DAYTON, OHIO 45444	SIZE A		5962-94532
		REVISION LEVEL	SHEET 12

4.2 Screening. For device class M, screening shall be in accordance with method 5004 of MIL-STD-883, and shall be conducted on all devices prior to quality conformance inspection. For device classes Q and V, screening shall be in accordance with MIL-I-38535, and shall be conducted on all devices prior to qualification and technology conformance inspection.

4.2.1 Additional criteria for device class M.

a. Burn-in test, method 1015 of MIL-STD-883.

(1) Test condition D. The test circuit shall be maintained by the manufacturer under document revision level control and shall be made available to the preparing or acquiring activity upon request. The test circuit shall specify the inputs, outputs, biases, and power dissipation, as applicable, in accordance with the intent specified in test method 1015.

(2) $T_A = +125^\circ\text{C}$, minimum.

b. Interim and final electrical test parameters shall be as specified in table II herein.

4.2.2 Additional criteria for device classes Q and V.

a. The burn-in test duration, test condition and test temperature, or approved alternatives shall be as specified in the device manufacturer's QM plan in accordance with MIL-I-38535. The burn-in test circuit shall be maintained under document revision level control of the device manufacturer's Technology Review Board (TRB) in accordance with MIL-I-38535 and shall be made available to the acquiring or preparing activity upon request. The test circuit shall specify the inputs, outputs, biases, and power dissipation, as applicable, in accordance with the intent specified in test method 1015.

b. Interim and final electrical test parameters shall be as specified in table II herein.

c. Additional screening for device class V beyond the requirements of device class Q shall be as specified in appendix B of MIL-I-38535.

4.3 Qualification inspection for device classes Q and V. Qualification inspection for device classes Q and V shall be in accordance with MIL-I-38535. Inspections to be performed shall be those specified in MIL-I-38535 and herein for groups A, B, C, D, and E inspections (see 4.4.1 through 4.4.4).

4.4 Conformance inspection. Quality conformance inspection for device class M shall be in accordance with MIL-STD-883 (see 3.1 herein) and as specified herein. Inspections to be performed for device class M shall be those specified in method 5005 of MIL-STD-883 and herein for groups A, B, C, D, and E inspections (see 4.4.1 through 4.4.4). Technology conformance inspection for classes Q and V shall be in accordance with MIL-I-38535 including groups A, B, C, D, and E inspections and as specified herein except where option 2 of MIL-I-38535 permits alternate in-line control testing.

4.4.1 Group A inspection.

a. Tests shall be as specified in table II herein.

b. Subgroups 5 and 6 in table I, method 5005 of MIL-STD-883 shall be omitted.

c. Subgroup 4 (C_{IN} measurement) shall be measured only for the initial test and after process or design changes which may affect input capacitance. A minimum sample size of 5 devices with zero rejects shall be required.

d. For device class M, subgroups 7 and 8 tests shall be sufficient to verify the functionality of the device. For device classes Q and V, subgroups 7 and 8 shall include verifying the functionality of the device; these tests shall have been fault graded in accordance with MIL-STD-883, test method 5012 (see 1.5 herein).

4.4.2 Group C inspection. The group C inspection end-point electrical parameters shall be as specified in table II herein.

STANDARDIZED MILITARY DRAWING DEFENSE ELECTRONICS SUPPLY CENTER DAYTON, OHIO 45444	SIZE A		5962-94532
		REVISION LEVEL	SHEET 13

4.4.2.1 Additional criteria for device class M. Steady-state life test conditions, method 1005 of MIL-STD-883:

- a. Test condition C or D. The test circuit shall be maintained by the manufacturer under document revision level control and shall be made available to the preparing or acquiring activity upon request. The test circuit shall specify the inputs, outputs, biases, and power dissipation, as applicable, in accordance with the intent specified in test method 1005.
- b. $T_A = +125^\circ\text{C}$, minimum.
- c. Test duration: 1,000 hours, except as permitted by method 1005 of MIL-STD-883.

TABLE II. Electrical test requirements.

Test requirements	Subgroups (in accordance with MIL-STD-883, TM 5005, table 1)	Subgroups (in accordance with MIL-I-38535, table III)	
	Device class M	Device class Q	Device class V
Interim electrical parameters (see 4.2)	1,7,9	1,7,9	1,7,9
Final electrical parameters (see 4.2)	1/ 1, 2, 3, 7, 8, 9, 10, 11	1/ 1, 2, 3, 7, 8, 9, 10, 11	2/ 1, 2, 3, 7, 8, 9, 10, 11
Group A test requirements (see 4.4)	1, 2, 3, 4, 7, 8, 9, 10, 11	1, 2, 3, 4, 7, 8, 9, 10, 11	1, 2, 3, 4, 7, 8, 9, 10, 11
Group C end-point electrical parameters (see 4.4)	2, 8a, 10	2, 8a, 10	2, 8a, 10
Group D end-point electrical parameters (see 4.4)	2, 8a, 10	2, 8a, 10	2, 8a, 10
Group E end-point electrical parameters (see 4.4)			

- 1/ PDA applies to subgroup 1.
- 2/ PDA applies to subgroups 1 and 7.

4.4.2.2 Additional criteria for device classes Q and V. The steady-state life test duration, test condition and test temperature, or approved alternatives shall be as specified in the device manufacturer's QM plan in accordance with MIL-I-38535. The test circuit shall be maintained under document revision level control by the device manufacturer's TRB, in accordance with MIL-I-38535, and shall be made available to the acquiring or preparing activity upon request. The test circuit shall specify the inputs, outputs, biases, and power dissipation, as applicable, in accordance with the intent specified in test method 1005.

4.4.3 Group D inspection. The group D inspection end-point electrical parameters shall be as specified in table II herein.

STANDARDIZED MILITARY DRAWING DEFENSE ELECTRONICS SUPPLY CENTER DAYTON, OHIO 45444	SIZE A		5962-94532
		REVISION LEVEL	SHEET 14

4.4.4 Group E inspection. Group E inspection is required only for parts intended to be marked as radiation hardness assured (see 3.5 herein). RHA levels for device classes Q and V shall be M, D, R, and M and for device class M shall be M and D.

- a. End-point electrical parameters shall be as specified in table II herein.
- b. For device class M, the devices shall be subjected to radiation hardness assured tests as specified in MIL-I-38535, appendix A, for the RHA level being tested. For device classes Q and V, the devices or test vehicle shall be subjected to radiation hardness assured tests as specified in MIL-I-38535 for the RHA level being tested. All device classes must meet the postirradiation end-point electrical parameter limits as defined in table I at $T_A = +25^{\circ}\text{C} \pm 5^{\circ}\text{C}$, after exposure, to the subgroups specified in table II herein.
- c. When specified in the purchase order or contract, a copy of the RHA delta limits shall be supplied.

5. PACKAGING

5.1 Packaging requirements. The requirements for packaging shall be in accordance with MIL-STD-883 (see 3.1 herein) for device class M and MIL-I-38535 for device classes Q and V.

6. NOTES

6.1 Intended use. Microcircuits conforming to this drawing are intended for use for Government microcircuit applications (original equipment), design applications, and logistics purposes.

6.1.1 Replaceability. Microcircuits covered by this drawing will replace the same generic device covered by a contractor-prepared specification or drawing.

6.1.2 Substitutability. Device class Q devices will replace device class M devices.

6.2 Configuration control of SMD's. All proposed changes to existing SMD's will be coordinated with the users of record for the individual documents. This coordination will be accomplished in accordance with MIL-STD-973 using DD Form 1692, Engineering Change Proposal.

6.3 Record of users. Military and industrial users shall inform Defense Electronics Supply Center when a system application requires configuration control and which SMD's are applicable to that system. DESC will maintain a record of users and this list will be used for coordination and distribution of changes to the drawings. Users of drawings covering microelectronic devices (FSC 5962) should contact DESC-EC, telephone (513) 296-6047.

6.4 Comments. Comments on this drawing should be directed to DESC-EC, Dayton, Ohio 45444-5270, or telephone (513) 296-5377.

6.5 Abbreviations, symbols, and definitions. The abbreviations, symbols, and definitions used herein are defined in MIL-I-38535 and MIL-STD-1331 and in table III.

TABLE III. Pin Descriptions.

Name	Function	Active State	Input/Output
Execution Control Pins			
CLK	Clock	High	I
RESET	System reset	High	I
HOLD	Bus hold	High	I
HLDA	Bus hold acknowledge	High	O
BREQ	Bus request	High	O
INT/CSB	Interrupt, code-size	High	I

STANDARDIZED MILITARY DRAWING DEFENSE ELECTRONICS SUPPLY CENTER DAYTON, OHIO 45444	SIZE A		5962-94532
		REVISION LEVEL	SHEET 15

6.5 Abbreviations, symbols, and definitions - continued.

Bus Interface Pins			
A31-A3	Address bus	High	0
BE7#-BE0#	Byte Enables	Low	0
D63-D0	Data Bus	High	I/O
LOCK#	Bus lock	Low	0
W/R#	Write/Read bus cycle	Hi/Low	0
NENE#	Next Near	Low	0
NA#	Next Address request	Low	I
READY#	Transfer Acknowledge	Low	I
ADS#	Address Status	Low	0
Cache Interface Pins			
KEN#	Cache Enable	Low	I
PTB	Page Table Bit	High	0
Testability Pins			
SHI	Boundary Scan Shift Input	High	I
BSCN	Boundary Scan Enable	High	I
SCAN	Shift Scan Path	High	I
Intel-Reserved Configuration Pins			
CC1-CC0	Configuration	High	I
Power and Ground Pins			
V _{CC}	System Power		
V _{SS}	System Ground		

<p align="center"> STANDARDIZED MILITARY DRAWING DEFENSE ELECTRONICS SUPPLY CENTER DAYTON, OHIO 45444 </p>	<p>SIZE A</p>		<p>5962-94532</p>
		<p>REVISION LEVEL</p>	<p>SHEET 16</p>

6.6 One part - one part number system. The one part - one part number system described below has been developed to allow for transitions between identical generic devices covered by the three major microcircuit requirements documents (MIL-H-38534, MIL-I-38535, and 1.2.1 of MIL-STD-883) without the necessity for the generation of unique PIN's. The three military requirements documents represent different class levels, and previously when a device manufacturer upgraded military product from one class level to another, the benefits of the upgraded product were unavailable to the Original Equipment Manufacturer (OEM), that was contractually locked into the original unique PIN. By establishing a one part number system covering all three documents, the OEM can acquire to the highest class level available for a given generic device to meet system needs without modifying the original contract parts selection criteria.

<u>Military documentation format</u>	<u>Example PIN under new system</u>	<u>Manufacturing source listing</u>	<u>Document listing</u>
New MIL-H-38534 Standardized Military Drawings	5962-XXXXXZZ(H or K)YY	QML-38534	MIL-BUL-103
New MIL-I-38535 Standardized Military Drawings	5962-XXXXXZZ(Q or V)YY	QML-38535	MIL-BUL-103
New 1.2.1 of MIL-STD-883 Standardized Military Drawings	5962-XXXXXZZ(M)YY	MIL-BUL-103	MIL-BUL-103

6.7 Sources of supply.

6.7.1 Sources of supply for device classes Q and V. Sources of supply for device classes Q and V are listed in QML-38535. The vendors listed in QML-38535 have submitted a certificate of compliance (see 3.6 herein) to DESC-EC and have agreed to this drawing.

6.7.2 Approved sources of supply for device class M. Approved sources of supply for class M are listed in MIL-BUL-103. The vendors listed in MIL-BUL-103 have agreed to this drawing and a certificate of compliance (see 3.6 herein) has been submitted to and accepted by DESC-EC.

STANDARDIZED MILITARY DRAWING DEFENSE ELECTRONICS SUPPLY CENTER DAYTON, OHIO 45444	SIZE A		5962-94532
		REVISION LEVEL	SHEET 17

STANDARDIZED MILITARY DRAWING SOURCE APPROVAL BULLETIN

DATE:

Approved sources of supply for SMD 5962-94532 are listed below for immediate acquisition only and shall be added to MIL-BUL-103 during the next revision. MIL-BUL-103 will be revised to include the addition or deletion of sources. The vendors listed below have agreed to this drawing and a certificate of compliance has been submitted to and accepted by DESC-EC. This bulletin is superseded by the next dated revision of MIL-BUL-103.

Standardized military drawing PIN	Vendor CAGE number	Vendor similar PIN 1/
5962-9453201MXX	34649	MG80860-25/B
5962-9453201MYX	34649	MQ80860-25/B
5962-9453202MXX	34649	MG80860-33/B
5962-9453202MYX	34649	MQ80860-33/B
5962-9453203MXX	34649	MG80860-40/B
5962-9453203MYX	34649	MQ80860-40/B

1/ Caution. Do not use this number for item acquisition. Items acquired to this number may not satisfy the performance requirements of this drawing.

Vendor CAGE number

34649

Vendor name and address

Intel corporation
2200 Mission College Blvd.
P.O. Box 58119
Santa Clara, CA 95052-8119

Point of Contact: 5000 W. Chandler Blvd.
Chandler, AZ 85226

The information contained herein is disseminated for convenience only and the Government assumes no liability whatsoever for any inaccuracies in this information bulletin.