

Features

- Frequency range : 1MHz to 200MHz
- SMD seam sealing ceramic package
- Supply voltage : 1.8V ~ 3.3V
- CMOS output
- Tri-state function available
- Dimensions L 2.5 x W 2.0 x H 0.8 mm
- AEC-Q100 compliant (option)
- RoHS compliant & Pb free

Applications

- Networking, Server, Storage
- Wireless communications
- Fibre channel, Ethernet, SATA, SAS, PCI-E, USB, WLAN, xDSL, xPON
- PC mainboard, Notebook, HDD, SSD, Graphics card, Computer peripherals
- Audio, Video, Gaming, Printer, DSC, IP CAM, Consumer products

Electrical Characteristics

Item	QTM252J	Conditions
Frequency Range (F_0)	1MHz ~ 125MHz	$V_{DD}=1.8V$
	1MHz ~ 200MHz	$V_{DD}=2.5V, 3.3V$
Frequency Stability (F_{stab})	± 50 ppm	Note [2]
Operating Temperature Range (T_{OTR})	$-40^{\circ}C \sim +85^{\circ}C$	
	$-40^{\circ}C \sim +105^{\circ}C$	
Supply Voltage (V_{DD})	Typ. 1.8V (1.65V ~ 1.95V) Typ. 2.5V (2.25V ~ 2.75V) Typ. 3.3V (2.97V ~ 3.63V)	
Current Consumption (I_{DD})	22 mA Max.	No load, $F_0=110MHz$, $V_{DD}=2.5V \sim 3.3V$
OE Mode Disable Current (I_{od})	18 mA Max.	OE=GND, output is Pulled Down
PDB Mode Standby Current (I_{std})	400 μA Typ.	OE=GND, output is Pulled Down
Output Type	CMOS	
Output Load (C_L)	15 pF	
Duty Cycle	45% ~ 55%	
Rise & Fall Time (T_r / T_f)	1.5 ns Typ.	$C_L=15pF$, 10%~90% V_{DD} high drive ($V_{DD}=2.5V, 3.3V$)
Output Voltage High (V_{OH})	$V_{DD} - 0.4$ Min.	$I_{OH}=-4mA$, $I_{OL}=4mA$, Standard Drive
Output Voltage Low (V_{OL})	0.4 Max.	
Input Voltage High (V_{IH})	70% V_{DD} Min.	Pin1, OE
Input Voltage Low (V_{IL})	30% V_{DD} Max.	
Start-up Time (T_{start})	5ms Typ. / 7ms Max.	Note [3]
OE Enable/Disable Time (T_{oe})	10 nS Max.	Note [4]
Resume Time (T_{resume})	7 mS Max.	In PDB mode, $T_a=25^{\circ}C$, $C_L=15pF$
PK-PK Period Jitter (T_{jitt})	200pS Typ. / 300pS Max.	$F_0=125MHz$, $V_{DD}=2.5V$ or 3.3V
	220pS Typ. / 300pS Max.	$F_0=125MHz$, $V_{DD}=1.8V$
Phase Jitter, RMS (T_{phj})	0.7pS Typ. / 1.0pS Max.	$F_0=125MHz$, $V_{DD}=3.3V$, integrated 12kHz~20MHz
First Year aging (F_{aging})	± 1.5 ppm Max.	at $25^{\circ}C \pm 3^{\circ}C$
10 Years Aging	± 5 ppm Max.	
Storage Temperature Range (T_{STR})	$-55^{\circ}C \sim +125^{\circ}C$	

Notes:

- [1] All electrical specifications in the above table are specified with 15pF output load and for all V_{DD} unless otherwise stated.
- [2] Inclusive of frequency tolerance at 25°C, 1st year aging at 25°C, and variations over operating temperature, supply voltage, and load.
- [3] Measure from the time V_{DD} reaches its rated minimum value.
- [4] OE function; $T_a = 25^\circ\text{C}$, $C_L = 15\text{pF}$. Add one clock period to this measurement for a usable clock output.

Dimensions & Pin Configuration

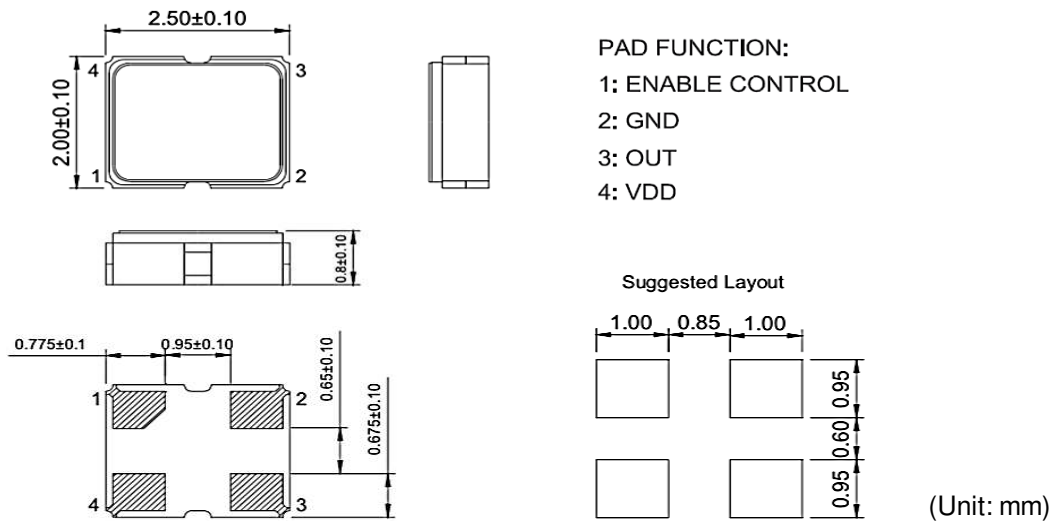

Pin	Symbol	Functionality	
1	OE	Output Enable	H or Open, Specified frequency output. L: output is high impedance. Only output driver is disabled.
		PDB mode (Option)	H or Open, Specified frequency output. L: output is low. Device goes to sleep mode. Supply current reduces to I_{std} .
2	GND	Ground	Electrical ground
3	OUT	Output	Oscillator output
4	VDD	Power	Power supply voltage

Test Circuit and Waveform

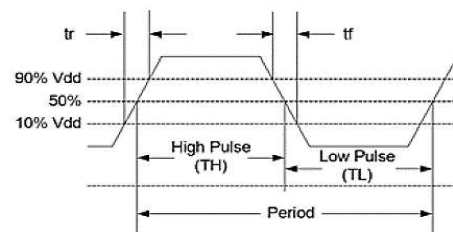
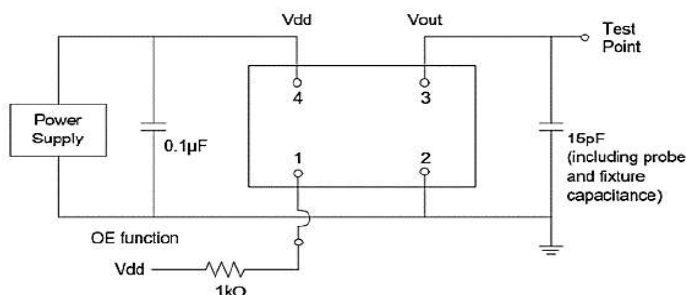

Test Diagram

Startup Timing (OE mode)

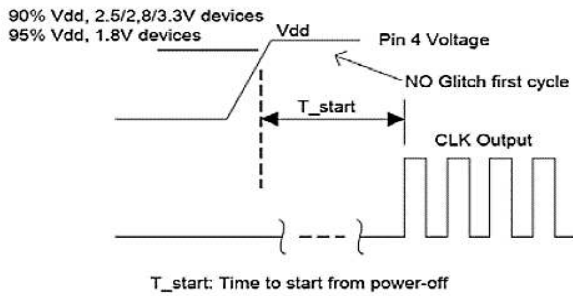

Standby Resume Timing (PDB mode)

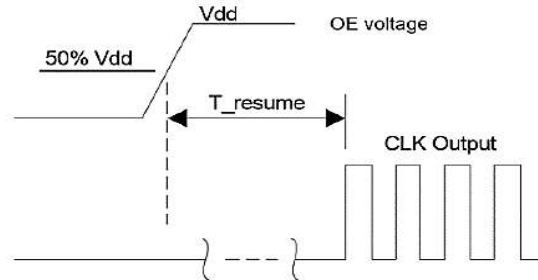

OE Enable Timing

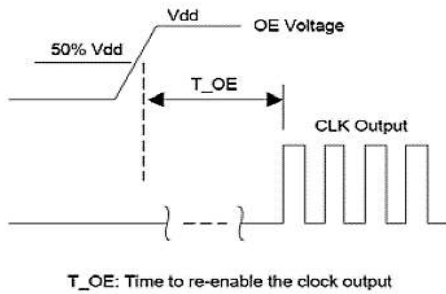

OE Disable Timing

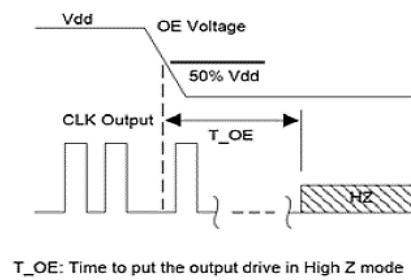

Ordering Information

QTM252J - 30.000M B E - T

Frequency in Hz

Please contact us for available frequencies

Supply Voltage

B	3.3 V
C	2.5 V
D	1.8 V

Packaging Method

T	Tape & Reel
---	-------------

Frequency Stability

E	± 50 ppm (-40°C ~ +85°C)
J	± 50 ppm (-40°C ~ +105°C)

Making

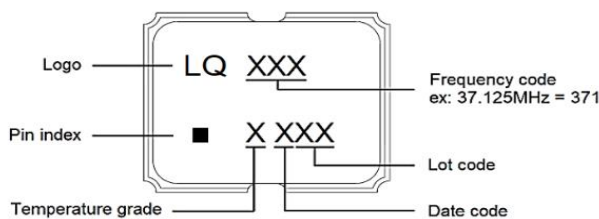

Temperature grade	Temperature range
I	-40°C ~ +85°C
E	-40°C ~ +105°C

Packing

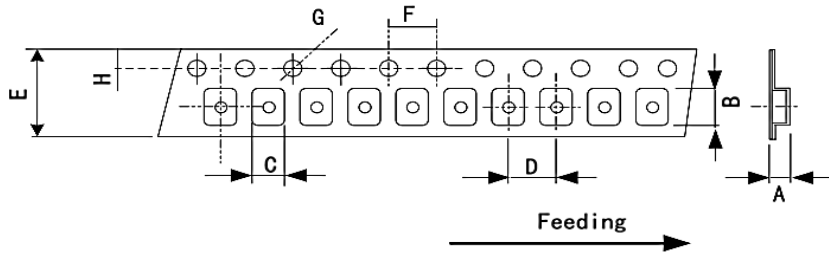

Dimensions	A	B	C	D	E	F	G	H	(Unit:mm)
	1.15 ±0.05	2.70 ±0.05	2.25 ±0.05	4.00 ±0.10	8.00 ±0.20	4.00 ±0.10	1.55 ±0.05	1.75 ±0.10	

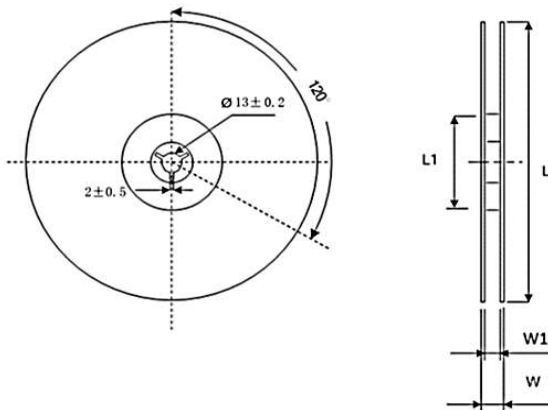
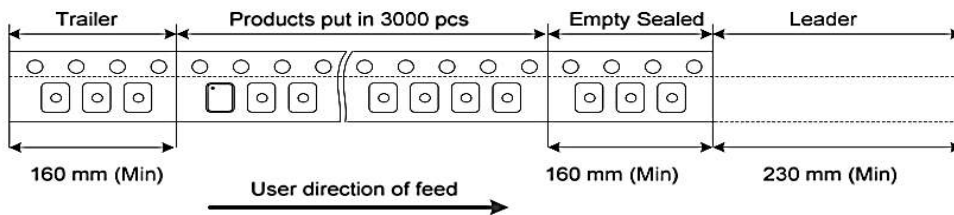

Dimensions	L	L1	W	W1	Standard Reel Quantity is 3,000 pcs per reel (Unit:mm)
	180 0/-3	60 +1/0	11.4 ±1	9 ±0.3	

Reflow Profile

Solder melting point : $220^{\circ}\text{C} \pm 10^{\circ}\text{C}$, 60 sec. Min.

Peak temperature : $260^{\circ}\text{C} \pm 10^{\circ}\text{C}$, 10 sec. Min.

